



Up-shine[®] Lighting



Technical Application
Guide for UP-SHINE
LED Under Cabinet Light

UP-DB10-24-16W-D

Introduction

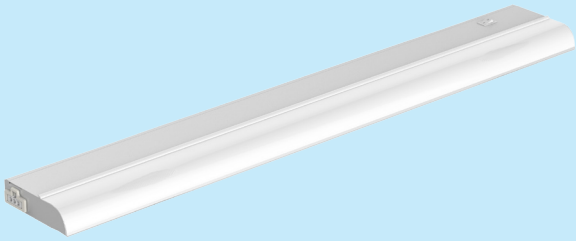

DB10 LED Under Cabinet Light, mainly designed for North American market. Energy consumption of DB10 is only one tenth of incandescent lamps, a quarter of energy saving lamps. It is slim, small in size, environment-friendly and long life. Simple installation saves the installation costs. There's input interface in both ends, clients could link the light one by one till max 400W according to different application requirements. Users could control each lamp separately since separate switch on lamp. The housing adopts high hardness SPCC sheet-metal. DB10 cabinet light adopt high lumen led chip with RA>90, cover is made by 94-V0 fire-rated PC. Uniform and soft light output offers the most comfortable light experience for customers. Six models optional: 12"-8W, 18"-12W, 24"-16W, 32"-22W, 41"-26W to meet different requirements.

- Up to 70% energy saving compared to standard CFL
- Long lifetime of 54,000 hours
- Dimmable when using triac dimmer
- 100° wide beam angle
- CCT: 2700K 3000K
4000K 5000K
- No UV/IR light
- Environment friendly, without Mercury or any other hazardous substances

Application notes

- Suitable for damp locations
- The lamp must be installed by professional electrician
- Ensure the power supply is switched off before fitting this product
- Do not touch the lamp when in use
- Keep away from hot steam and corrosive gas

Application Areas

Low power version is applicable to cabinet and closet. High power version is applicable to meeting room, hospital, hotel, and shopping mall etc.

Certificate

RoHS



Product Information

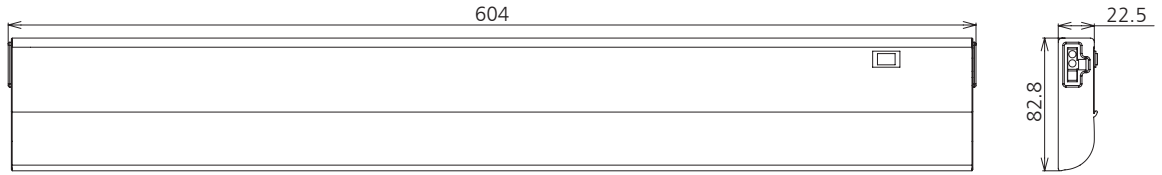

Technical Specifications

Model	Voltage	Power	Power Factor	Lumen (±5%)	Beam angle	CCT	Lifespan	CRI	Dimmable	Dimension
UP-DB10-24-16W-D	AC120V	16W	≥0.9	1120	100°	2700K	54000h	≥90	Yes	L604*W82.8*H22.5mm
UP-DB10-24-16W-D	AC120V	16W	≥0.9	1280	100°	3000K	54000h	≥90	Yes	L604*W82.8*H22.5mm
UP-DB10-24-16W-D	AC120V	16W	≥0.9	1360	100°	4000K	54000h	≥90	Yes	L604*W82.8*H22.5mm
UP-DB10-24-16W-D	AC120V	16W	≥0.9	1440	100°	5000K	54000h	≥90	Yes	L604*W82.8*H22.5mm

Driver data Sheet

Driver data	Main Power
Input rated Voltage	AC120V
Frequency	60Hz
Input Voltage	AC100-130V
Efficiency	≥78%
Total load Wattage	16W±1W
Power Factor	≥0.9
Rated input current	≤0.19A
Full load output Voltage	24-32V
Rated output current	450mA
Output current range	450mA±5%
Power tolerance	±5%
Current output tolerance	±5%
Dimming range	8%-100%
Dimmer	Lutron dimmers
Short circuit protection	PASS
Over voltage protection	PASS
Over temperature protection	PASS
THD	<20%
Withstand voltage	AC1500V

Fixture Compatibility

Rated Wattage	Electrical Classification	Operating Temp	Operating Humidity	Storage Temp
16W	I	-20°C~45°C	0~90%	-20°C~65°C

Spectral Distribution

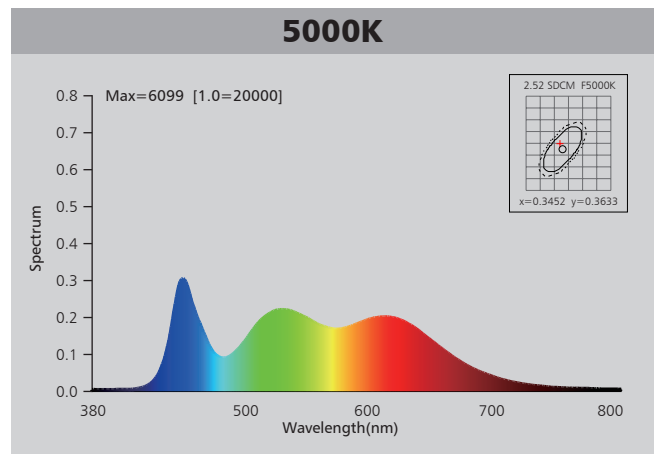
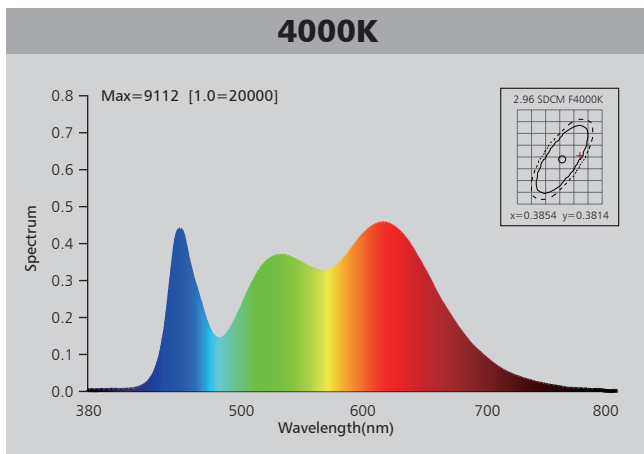
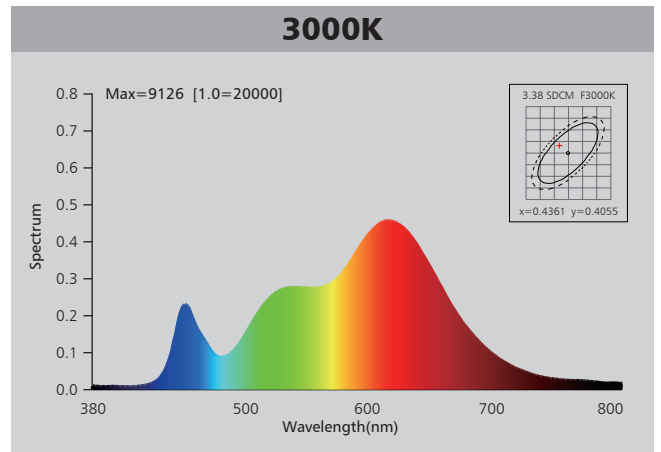
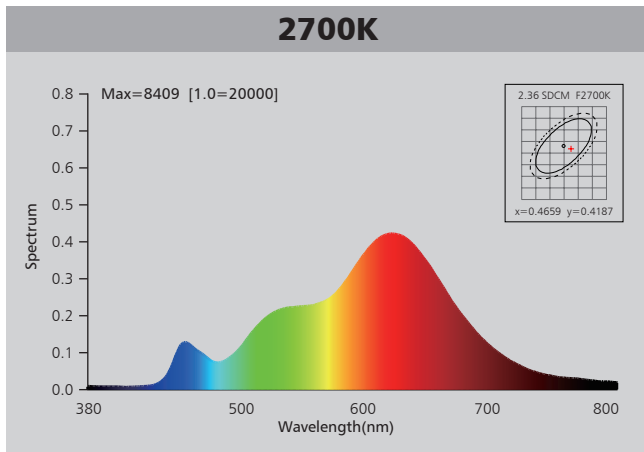

Photometric Diagram

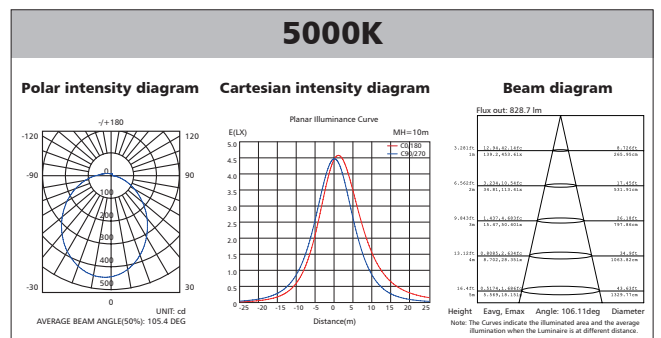
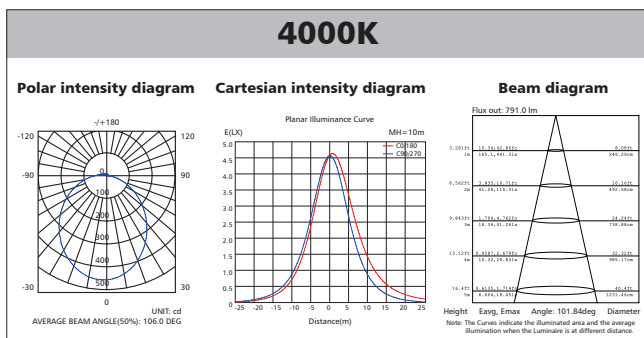
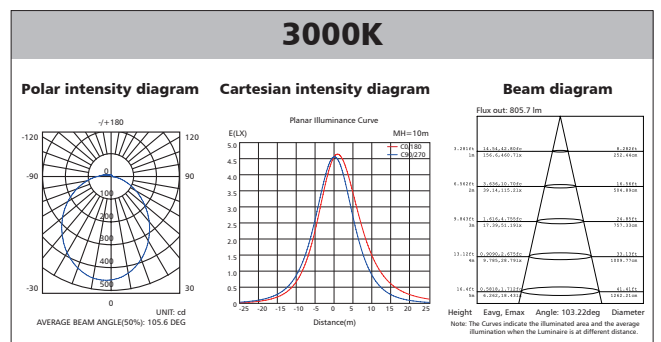
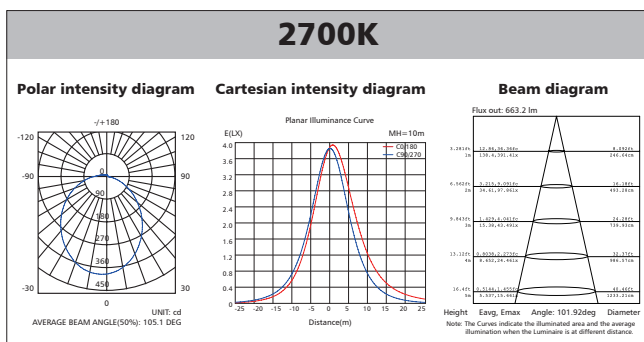

Polar Diagram Comparison

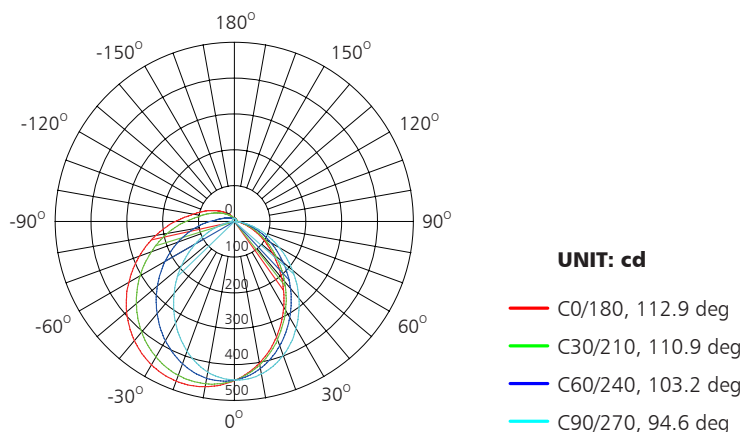

AVERAGE BEAM ANGLE (50%): 105.4DEG



Driver lifetime & LED light decay rate

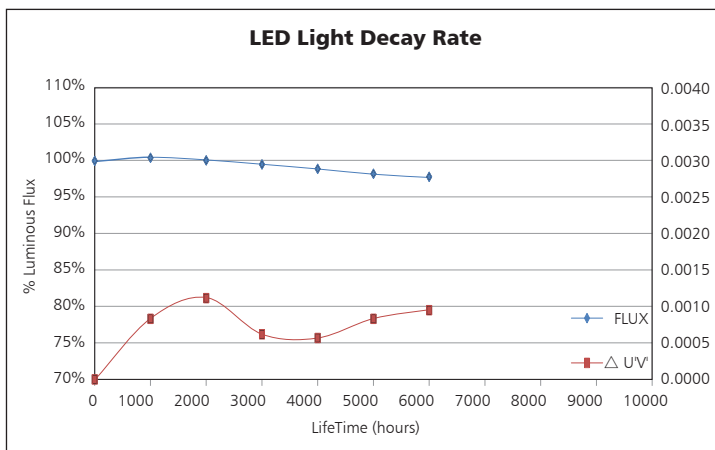
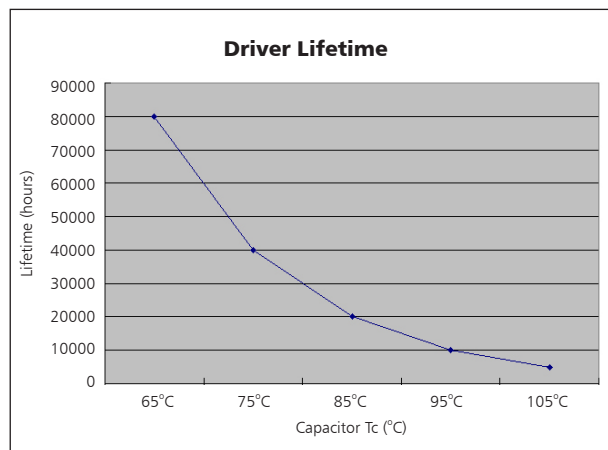

Temperature

- The testing is operated at 25°C
- The lifetime of capacitor, minimum of 5,000 hours if operated at 105°C, will be doubled whenever the temperature drops 10°C
- The highest withstand temperature of IC, MOS could be 120°C
- The highest withstand temperature of LED junction temperature is 150°C

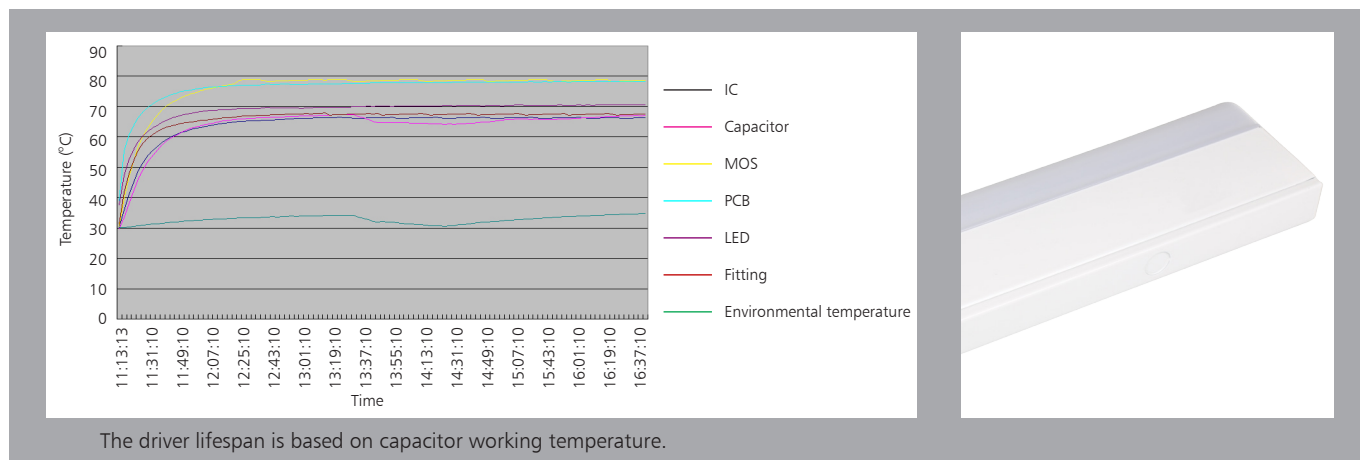

Mounting Fixture:

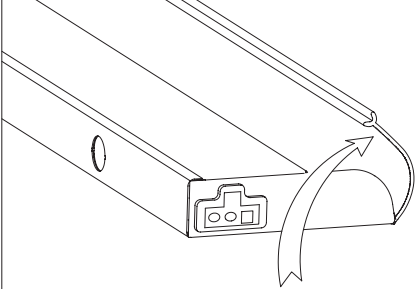

Remove the lens cover from the fixture by lifting its back edge up gently and rotating it toward the front of fixture. See Figure 1. Determine desired location of fixture and mark location of mounting holes (mark at the small end of each keyhole slot).

Step 1

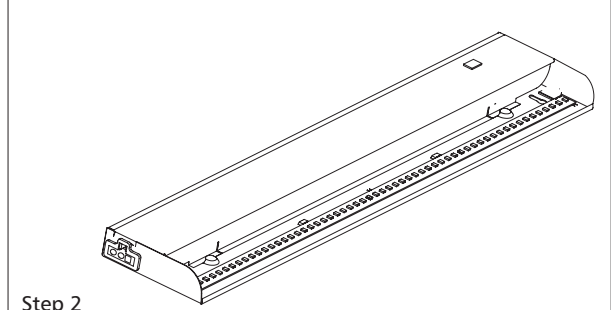

Step 2

Detach cover of wiring compartment by squeezing its front edge and rotating it backward in its self-hinge.

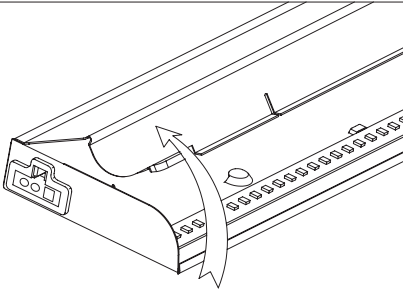

Step 3

Use a drill gun (or start holes with a awl) and screw in mounting screws at installation locations, ensure the cabinet light securely fixed.

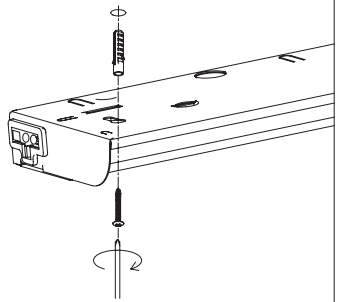

Step 4

Step 5

Cable Connection Terminal Cover

Hose Coupler

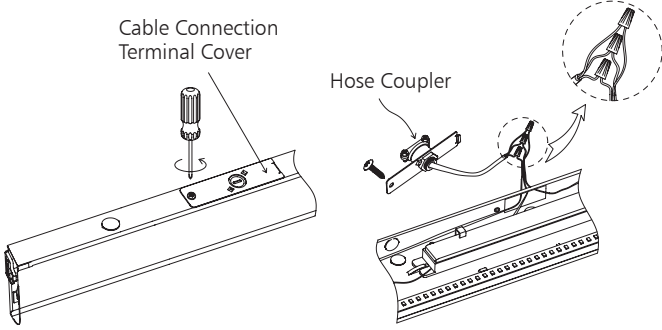

N= White
 L= Black
 G= Yellow-Green

Unscrew the the terminal cover screws by screwdriver, open the cover and punch out the knockout holes, then fasten the hose coupler. Connect the external hose to the hose coupler, thread the power wires through the hose and connect it to the lead wires of lamp by a spiral terminal.

Replace the wiring compartment cover, securing lip under metal retaining tabs. See Figure 6. NOTE: Be sure that the wires are not pinched or damaged by any part of the housing or cover.

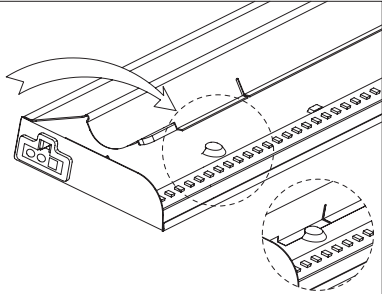

Step 6

Replace the lens cover by tucking front edge and pressing down firmly along its entire length until it is secure.

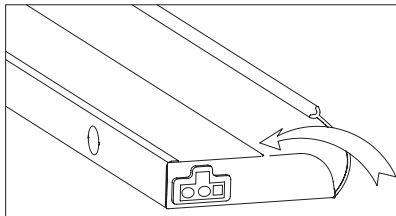

Step 7

Plug-in Installation:

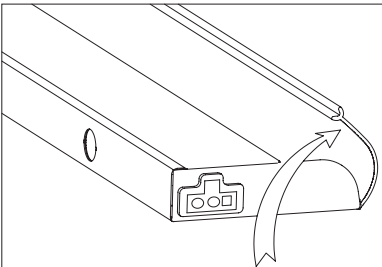

Remove the lens cover from the fixture by lifting its back edge up gently and rotating it toward the front of fixture.

Step 1

Use a drill gun (or start holes with a awl) and screw in mounting screws at installation locations, ensure the cabinet light securely fixed.

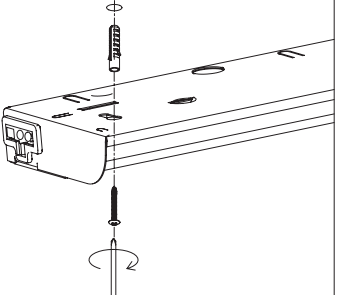

Step 2

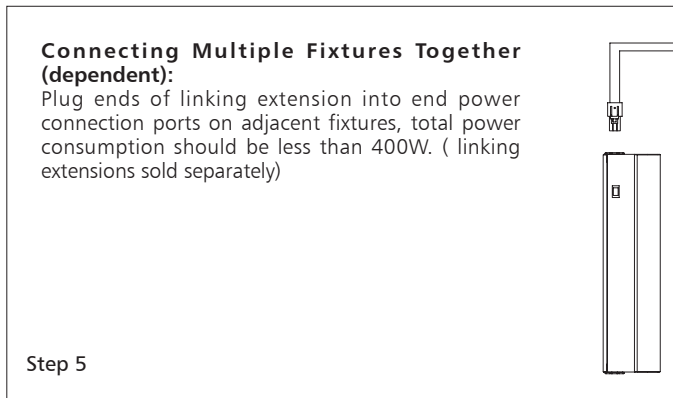
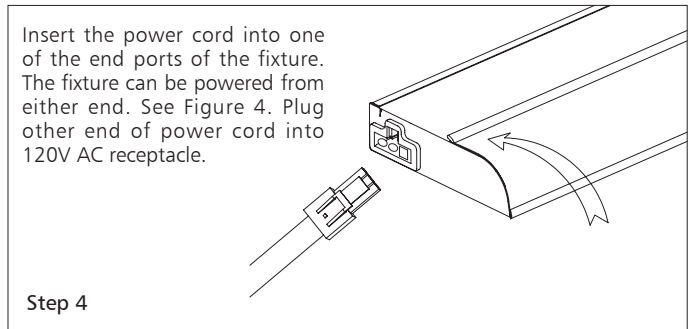
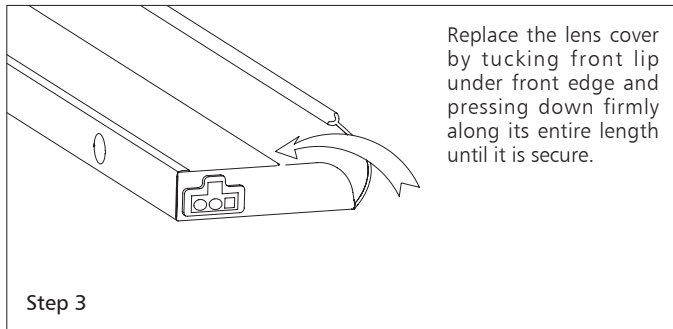

Packaging Information

	SIZE(CM)	N.W/pc (KGS)	G.W.(KGS)	Q'TY(PCS)
Carton	70.5*20.5*20	0.805	11.5	12

	CTNS	Q'TY(PCS)	VOLUME(CBM)
20" standard container	936	11232	28
40" standard container	1872	22464	56

