



UPSHINE®



Technical Application
Guide for UP SHINE
LED Downlight
UP-DL109-4-10W-D

Introduction



DL109 model is a led down light with graceful and ultra-thin design. The special optical diffuser can increase central candela intensity by more than 30%, provide soft and comfortable lighting. The lamp adopts spring installation and can be installed in the ceiling directly without Junction box installed in advance, greatly decrease the installation and maintenance cost. Metallic driver box with connection holes reserved can be connected directly to the metal hose.

- Up to 70% energy saving compared to standard CFL
- Long lifetime of 36,000 hours
- Dimmable when using triac dimmer
- 90° wide beam angle
- CCT: 2700K 3000K 3500K 4000K
- No UV/IR light
- Environment friendly, without Mercury or any other hazardous substances

Application notes

- For Wet location
- Professional electrician for installation only
- Switch off before installation
- Do not touch when in use
- Keep away from hot steam and corrosive gas

Application Areas

Suitable for commercial and residential applications like offices, supermarkets, shops, schools, hotels, restaurants, workshop, warehouse, homes etc.



Product Information

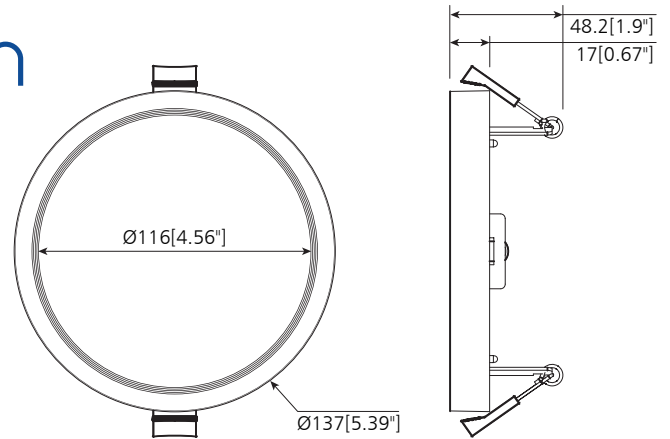

Technical Specifications

Model	Voltage	Power	Power Factor	Lumen (±5%)	Beam angle	CCT	Lifespan	CRI	Dimmable	Dimension
UP-DL109-4-10W-D	AC120V	10W	≥0.9	850	90°	2700K	36000h	≥80	Yes	Ø137*48.2mm
				850		3000K				
				880		3500K				
				880		4000K				

Driver data Sheet

Driver data	DIM
Input rated Voltage	AC120V
Frequency	60Hz
Input Voltage	AC100-130V
Efficiency	≥80%
Total load Wattage	10W±1W
Power Factor	≥0.9
Rated input current	≤0.12A
Full load output Voltage	DC24-38V
Rated output current	270mA
Output current range	270mA±5%
Power tolerance	±5%
Current output tolerance	±5%
Dimming range	8%-100%
Dimmer	Triac dimmers
Short circuit protection	PASS
Over voltage protection	PASS
Over temperature protection	PASS
THD	≤20%
Withstand voltage	1.5KV / 60S / 5mA

Fixture Compatibility

Rated Wattage	Electrical Classification	Ingress Protection	Operating Temp	Operating Humidity	Storage Temp
10W	With ground	Wet location	-20°C~45°C	0~90%	-20°C~65°C

Spectral Distribution

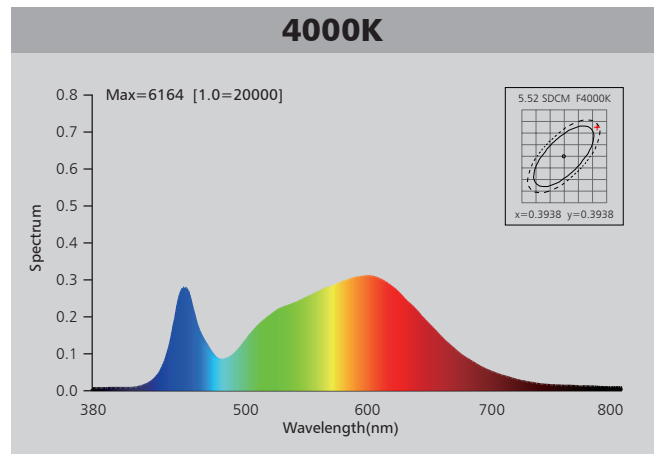
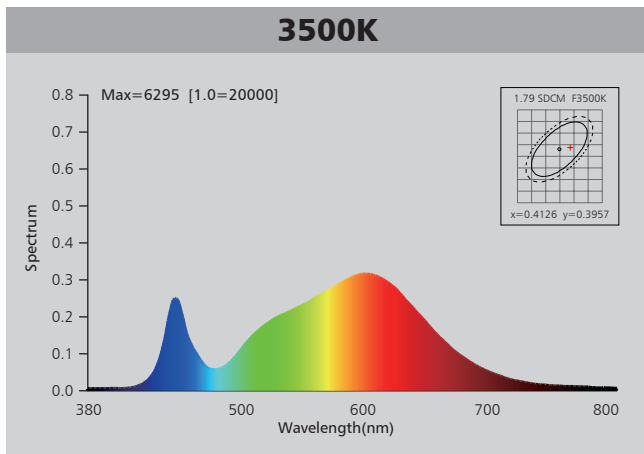
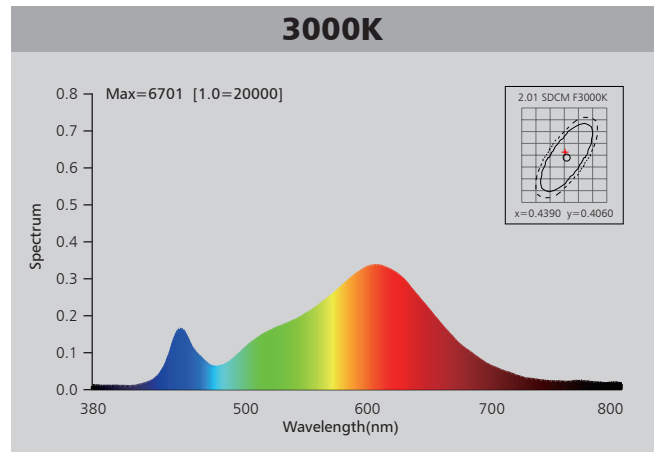
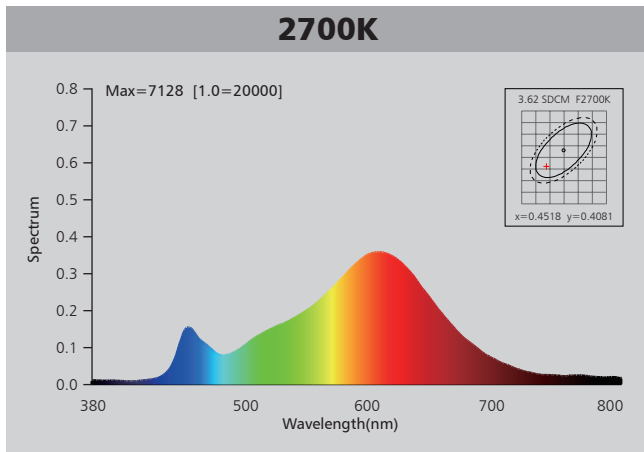

Photometric Diagram

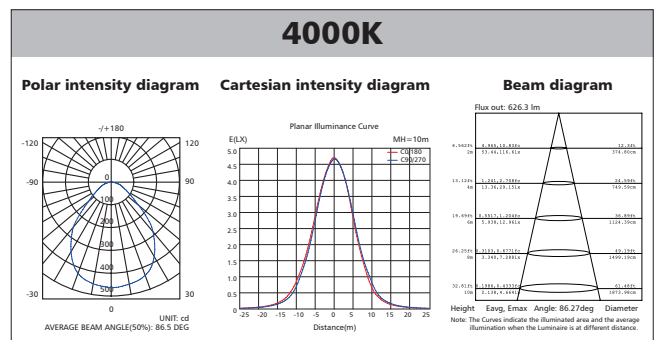
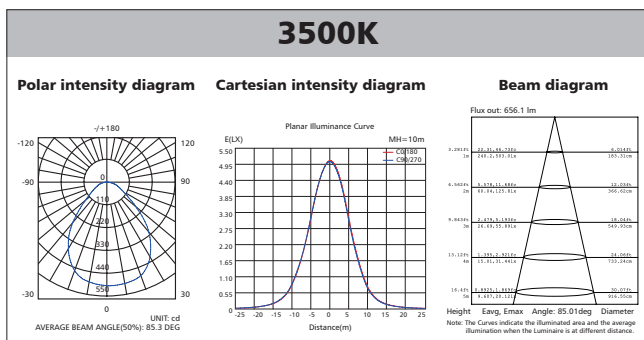
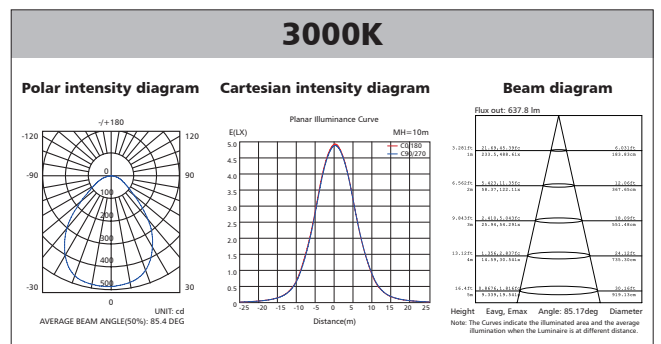
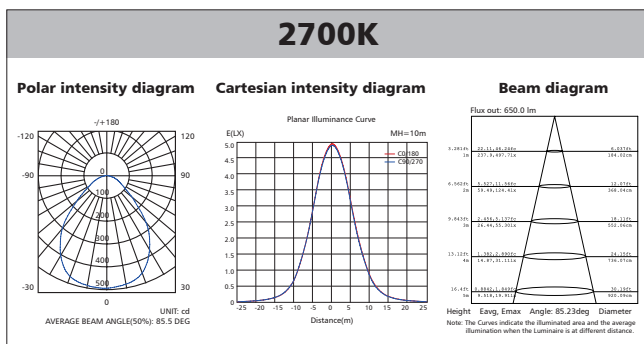

Polar Diagram Comparison

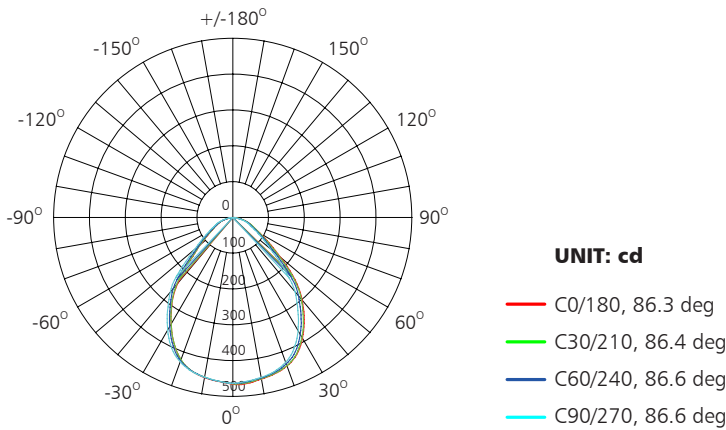

AVERAGE BEAM ANGLE (50%): 86.5DEG



Driver lifetime & LED light decay rate

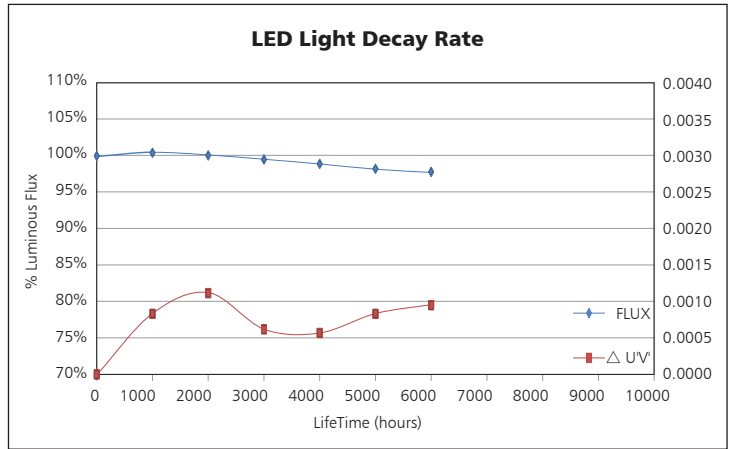
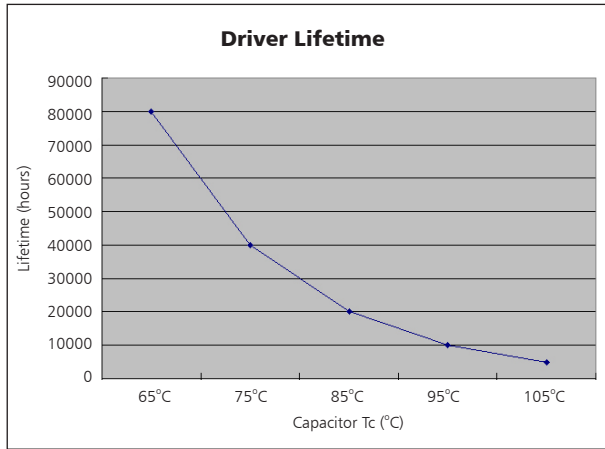

Temperature

- The testing is operated at 25°C
- The lifetime of capacitor, minimum of 5,000 hours if operated at 105°C, will be doubled whenever the temperature drops 10°C.
- The highest withstand temperature of IC, MOS could be 120°C
- The highest withstand temperature of LED junction temperature is 150°C

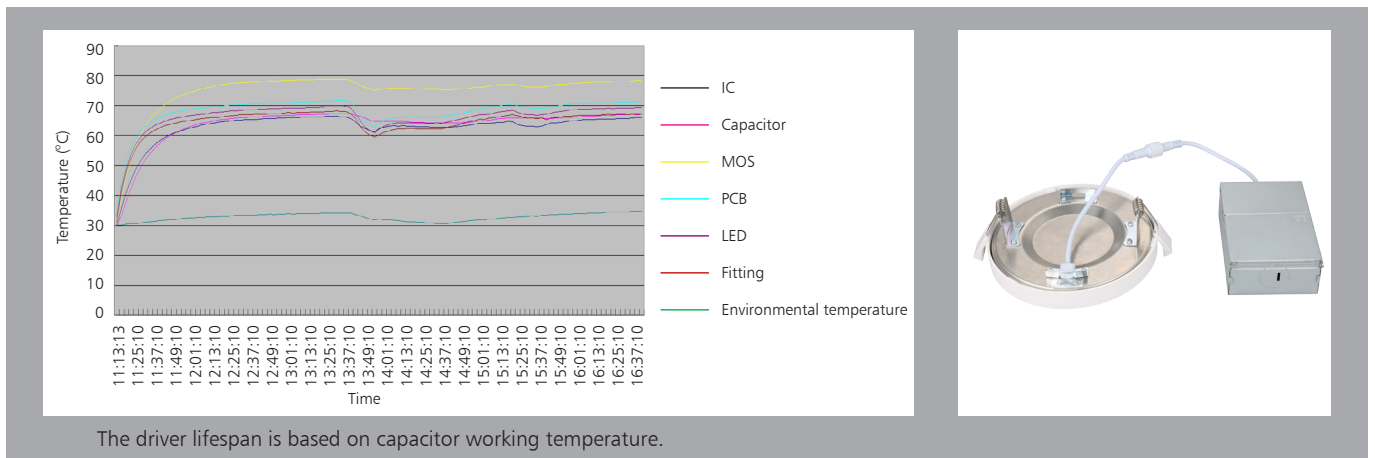

The driver lifespan is based on capacitor working temperature.



Installation

1. The upper space above the ceiling height should be no less than 80 mm (see FIG.1)
2. Opening a hole in ceiling according to cutout size of the lamp (see FIG.1).
3. Punch out the knockout in driver box and attach line voltage AC supply wires to fixture lead wires (L-Black, N-White) inside the driver box. Secure each connection using the quick connector provided. Fix the driver box in a proper position by screw. (see FIG.2).
4. Connect the lamp and driver (see FIG.2).
5. Hold back spring clips then push the lamp into the hole. (see FIG3).
6. Installation completed. Switch on.

Note:

For wet locations. In accordance with Underwriters Laboratories requirements, a line of caulking compound such as acrylic latex or silicone must be placed around the perimeter of backplate also contacting the flange (as shown) to seal against mounting surface keeping water away from the outlet box and back opening.

FIG. 1

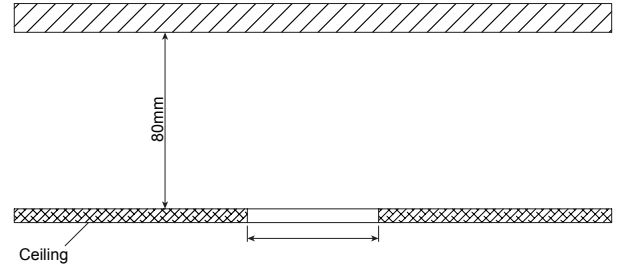

FIG. 2

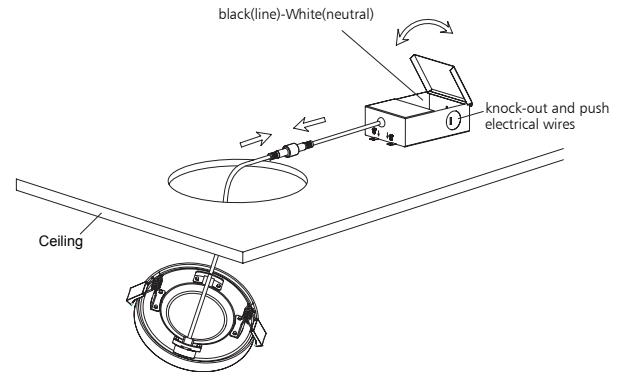

FIG. 3

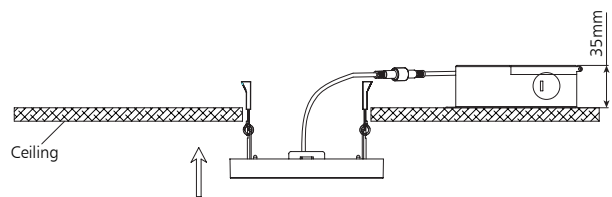

FIG. 4

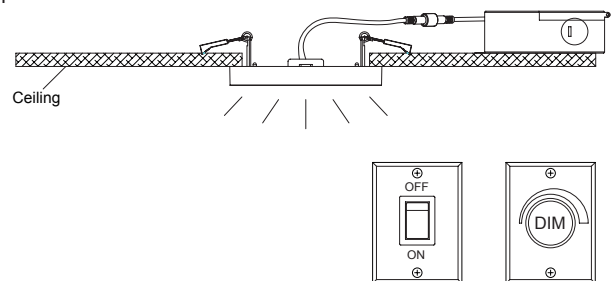
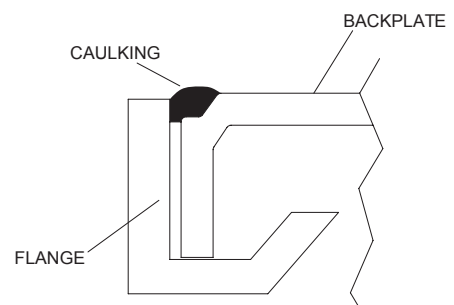

FIG. 5



Packaging Information

	SIZE(CM)	N.W/pc (KGS)	G.W.(KGS)	Q'TY(PCS)
Carton	47.5*37*45	0.33	14	36

	CTNS	Q'TY(PCS)	VOLUME(CBM)
20" standard container	348	12528	28
40" standard container	698	25128	56

