

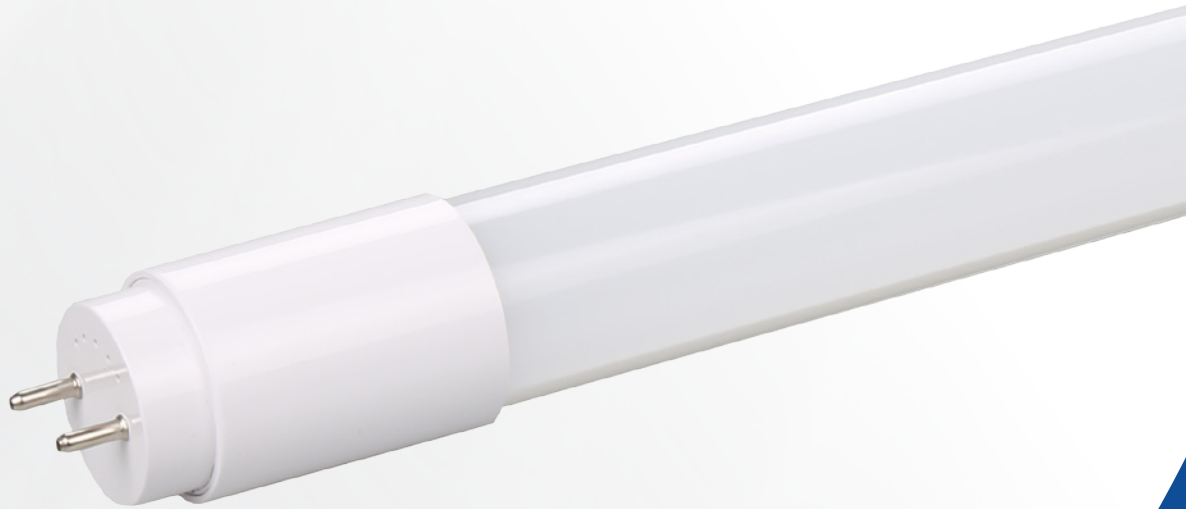

Up-shine[®] Lighting



Technical Application
Guide for UP SHINE
LED Tube Light
UP-T810W600-X

Introduction



Up-shine high lumen and practical tube T8 adopts complete PC cover, using 2835SMD LED as light source, CRI > 80. V0 fire-rated full PC cover ensures high light transmittance and safe installation. No yellowing and cracking. With Built-in aluminum heatsink, our T8 tubes achieve high lighting performance and good heat dissipation.

- Up to 70% energy saving compared to traditional tube
- Long lifetime of 40,000 hours
- 120° wide beam angle
- 600mm length
- CCT: 3000K 4000K
5000K 5700K
- No UV/IR light
- Environment friendly, without Mercury or any other hazardous substances

Application notes

- IP20 for indoor use
- Professional electrician for installation only
- Switch off before installation
- Do not touch when in use
- Keep away from hot steam and corrosive gas

Application Areas

Suitable for commercial and residential applications like offices, supermarkets, shops, schools, hotels, restaurants, workshop, warehouse, homes etc.

Certificates

CE **RoHS**



Product Information

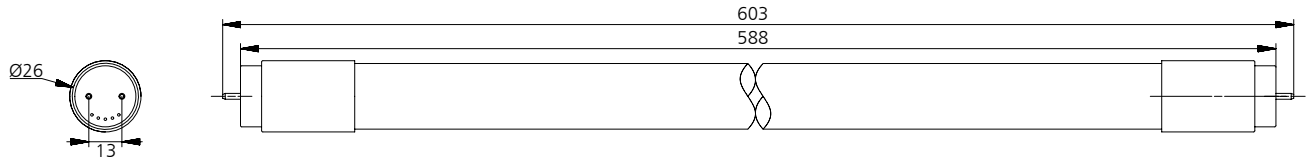

Technical Specifications

Model	Voltage	Power	Power Factor	Lumen (±5%)	Beam angle	CCT	Lifespan	CRI	Dimmable	Dimension
UP-T810W600-X	AC100-240V	10W	≥0.9	1160	120°	3000K	40000h	≥80	No	Ø26*603mm
UP-T810W600-X	AC100-240V	10W	≥0.9	1150	120°	4000K	40000h	≥80	No	Ø26*603mm
UP-T810W600-X	AC100-240V	10W	≥0.9	1160	120°	5000K	40000h	≥80	No	Ø26*603mm
UP-T810W600-X	AC100-240V	10W	≥0.9	1240	120°	5700K	40000h	≥80	No	Ø26*603mm

Driver data Sheet

Driver data	Non-dim
Input rated Voltage	AC100-240V
Frequency	50/60HZ
Input Voltage	AC85-265V
Efficiency	≥85%
No load wattage	≤0.5W
Total load Wattage	10W±1W
Power Factor	≥0.9
Rated input current	≤0.15A
Full load output Voltage	DC65-75V
Rated output current	130mA
Output current range	130mA±5%
Power tolerance	±5%
Current output tolerance	±5%
Short circuit protection	PASS
Over temperature protection	PASS
THD	≤20%
Withstand Voltage	AC3000V

Fixture Compatibility

Rated Wattage	Electrical Classification	Ingress Protection	Operating Temp	Operating Humidity	Storage Temp
10 W	II	IP20	-20°C~45°C	0~90%	-20°C~65°C

Spectral Distribution

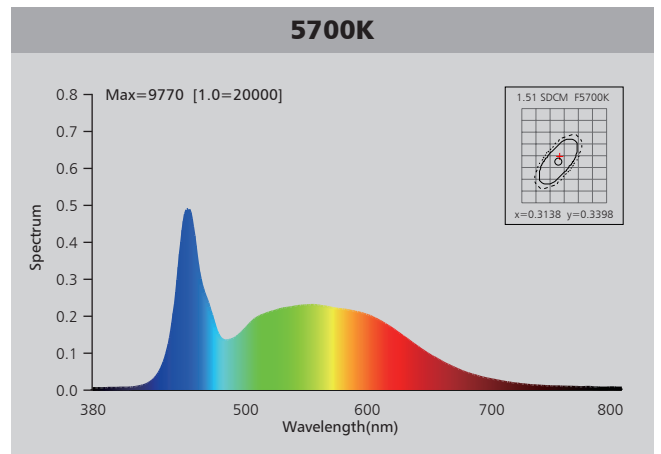
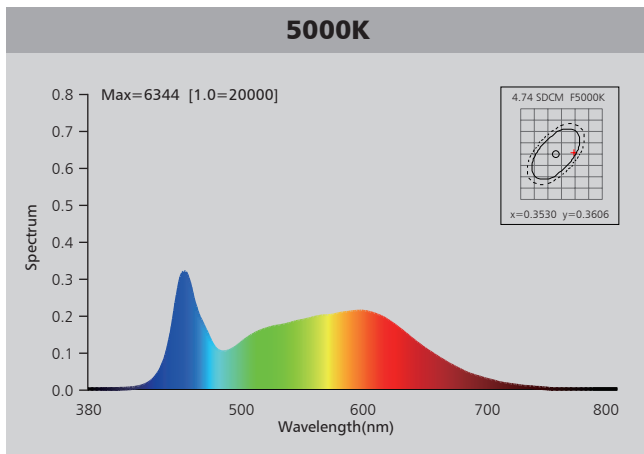
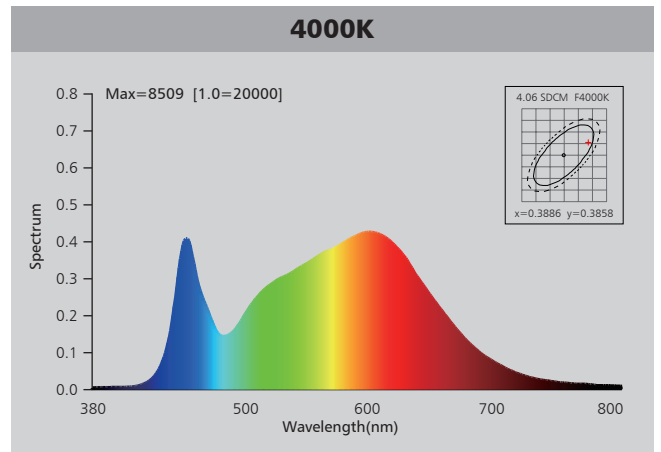
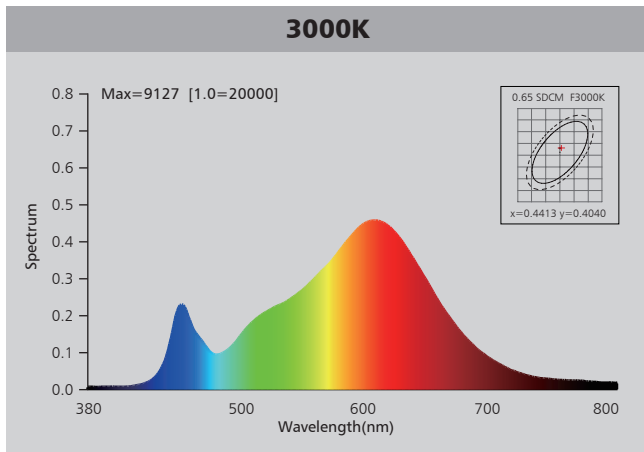

Photometric Diagram

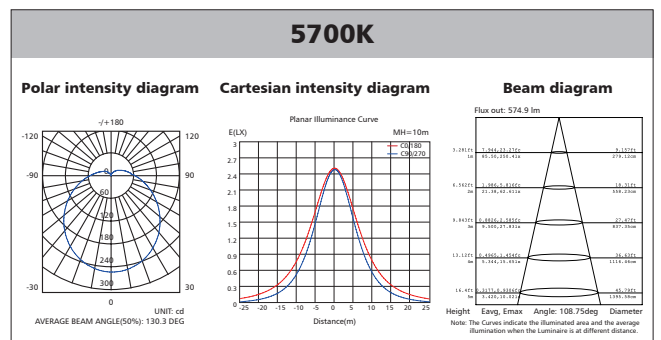
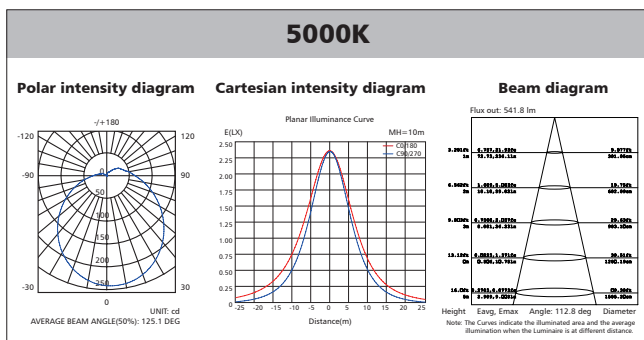
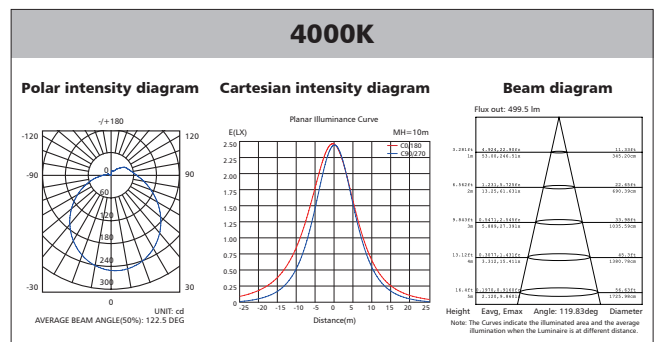
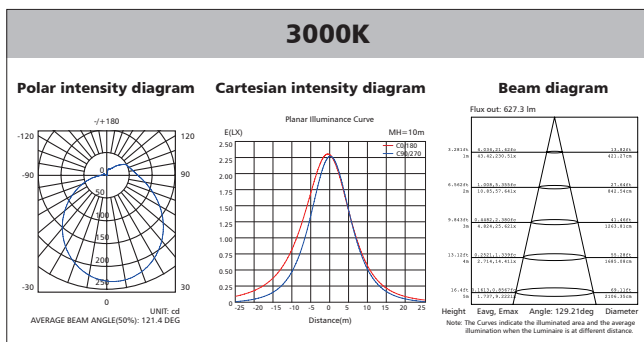

Polar Diagram Comparison

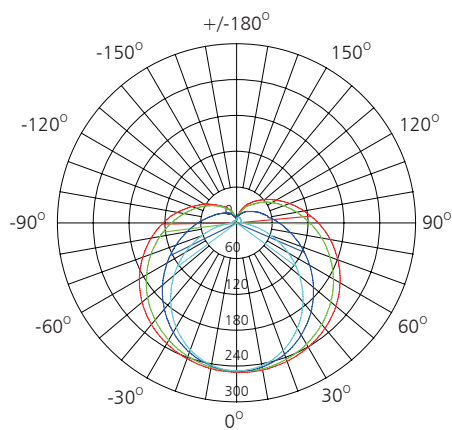

UNIT: cd

- C0/180, 124.4 deg
- C30/210, 122.1 deg
- C60/240, 130.3 deg
- C90/270, 107.3 deg

AVERAGE BEAM ANGLE (50%): 118.5DEG



Driver lifetime & LED light decay rate

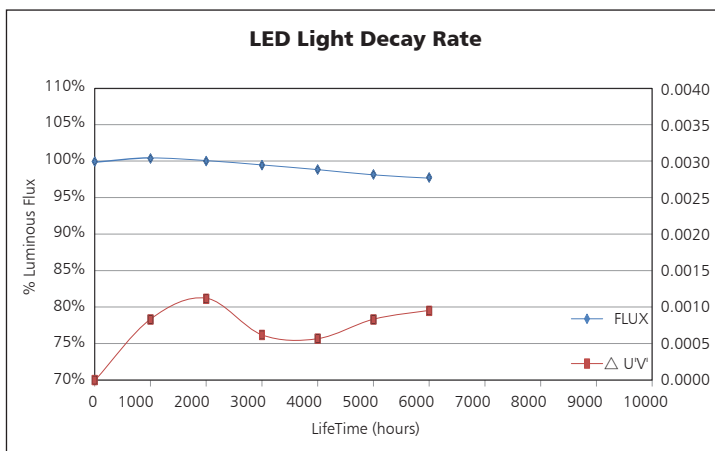
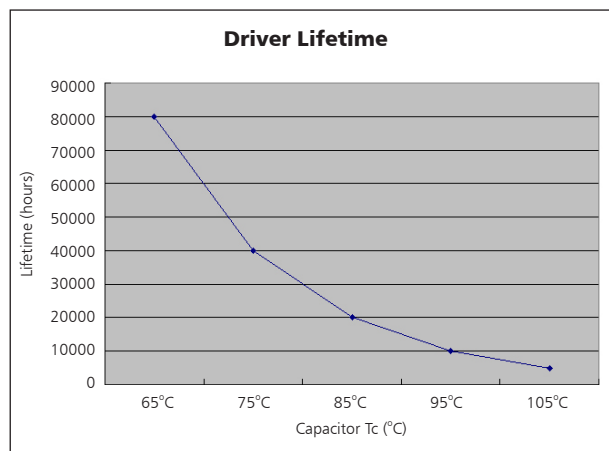

Temperature

- The testing is operated at 25°C
- The lifetime of capacitor, minimum of 5,000 hours if operated at 105°C, will be doubled whenever the temperature drops 10°C
- The highest withstand temperature of IC, MOS could be 120°C
- The highest withstand temperature of LED junction temperature is 150°C

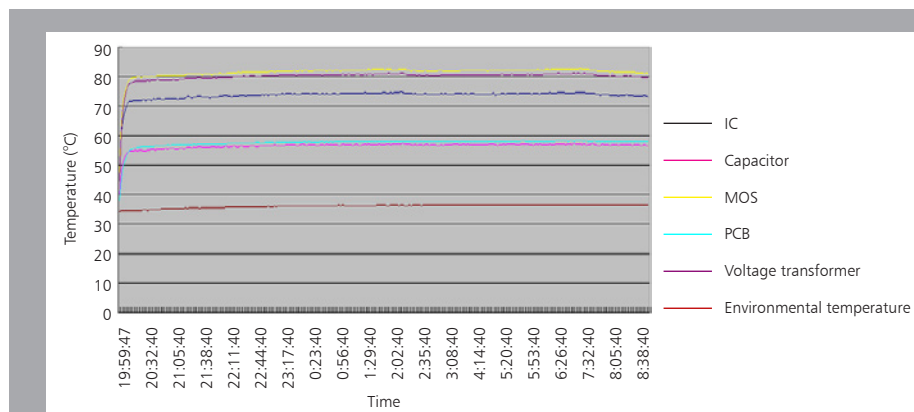

The driver lifespan is based on capacitor working temperature.



Installation

1. Two end power tube, installation with Electronic Ballast

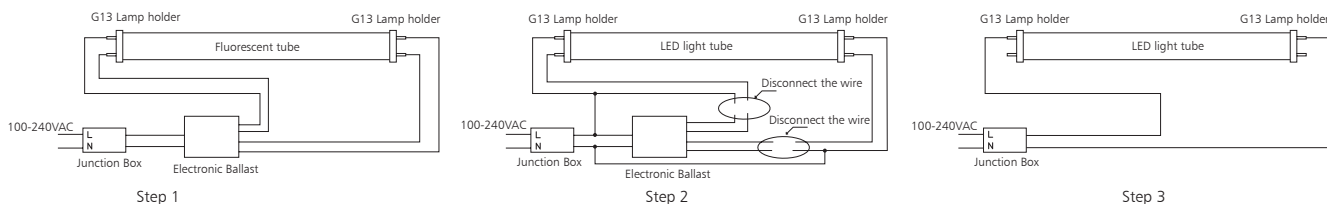

2. Two end power tube, installation with Inductive Ballast

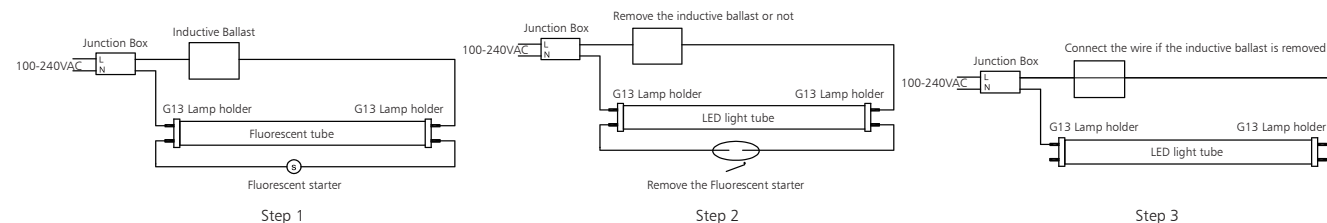

Packaging Information

	SIZE(CM)	N.W/pc (KGS)	G.W.(KGS)	Q'TY(PCS)
Carton	69.3*21*21	0.1	6	25

	CTNS	Q'TY(PCS)	VOLUME(CBM)
20" standard container	887	22175	28
40" standard container	1774	44350	56

