



Up-shine[®] Lighting



Technical Application Guide for UP-SHINE LED Spotlight

UP-TL21-20W

Introduction

UP-TL21A-20W

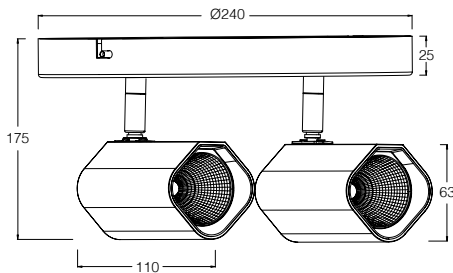

UP-TL21B-20W

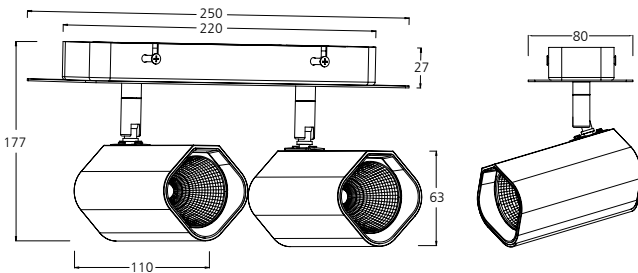

To gaze is to look steadily and intently at that which excites admiration, curiosity or interest; to gaze with eyes wide open, as from surprise, wonder, alarm, stupidity; to gaze unbelievably or rudely.

The newly developed T-Gazer track light looks like a Gazer on the track; it is designed in combination of square and circular, they are masterly joined together to demonstrate behavioral philosophies of oriental, this design is clear-cut but not abrupt, soft but not monotonous, perfectly integrated into different lighting applications. With high light efficiency, deep cylinder design for light outlet makes the light softer and cozier. Modularization design facilitates replacing universal head connection elements, which realizes diversified installation ways in one lamp. Dimmable available, compatible with a wide range of recommended Triac dimmers.

- Up to 70% energy saving compared to standard CFL
- Long lifetime of 40,000 hours
- 15°/24°/36°/60° beam angle
- CCT: 2700K 3000K
4000K 5000K
- No UV/IR light
- Environment friendly, without Mercury or any other hazardous substances
- UGR<19

Application notes

- IP20 for indoor use only
- Professional electrician for installation only
- Switch off before installation
- Do not touch when in use
- Keep away from hot steam and corrosive gas

Application Areas

It is suitable for supermarket, specialty store, show window, exhibition hall; focus lighting, decorative and background lighting, where attention is focused on subjects to emphasize special visual points.

Certificate



Product Information

Technical Specifications

Power	Voltage	Power Factor	Lumen (±5%)	Beam angle	CCT	Lifespan	CRI	Dimmable
20W	AC100-240V	≥0.9	1340	15°/24°/36°/60°	2700K	40000h	≥80	No
20W	AC100-240V	≥0.9	1540	15°/24°/36°/60°	3000K	40000h	≥80	No
20W	AC100-240V	≥0.9	1560	15°/24°/36°/60°	4000K	40000h	≥80	No
20W	AC100-240V	≥0.9	1610	15°/24°/36°/60°	5000K	40000h	≥80	No
20W	AC230V	≥0.9	1270	15°/24°/36°/60°	2700K	40000h	≥80	Yes
20W	AC230V	≥0.9	1340	15°/24°/36°/60°	3000K	40000h	≥80	Yes
20W	AC230V	≥0.9	1440	15°/24°/36°/60°	4000K	40000h	≥80	Yes
20W	AC230V	≥0.9	1500	15°/24°/36°/60°	5000K	40000h	≥80	Yes

Driver data Sheet

Driver data	DIM	Non-dim
Input rated Voltage	AC230V	AC100-240V
Frequency	50Hz	50/60Hz
Input Voltage	AC200-240V	AC85-265V
Efficiency	≥79%	≥78%
Total load Wattage	2*10W±0.5W	2*10W±0.5W
Power Factor	≥0.9	≥0.9
Rated input current	≤2*0.06A	≤2*0.12A
Full load output Voltage	DC28-38V	DC23-40V
Rated output current	2*230mA	2*250mA
Output current range	2*230mA±5%	2*250mA±5%
Power tolerance	±5%	±5%
Current output tolerance	±5%	±5%
Dimming range	8%-100%	--
Dimmer	Triac dimmers	--
Short circuit protection	PASS	PASS
Over voltage protection	PASS	PASS
Over temperature protection	PASS	PASS
THD	<20%	<18%
Withstand voltage	AC1500V	AC1500V

Fixture Compatibility

Rated Wattage	Electrical Classification	Ingress Protection	Operating Temp	Operating Humidity	Storage Temp
20W	I	IP20	-20°C~45°C	0~90%	-20°C~65°C

Spectral Distribution

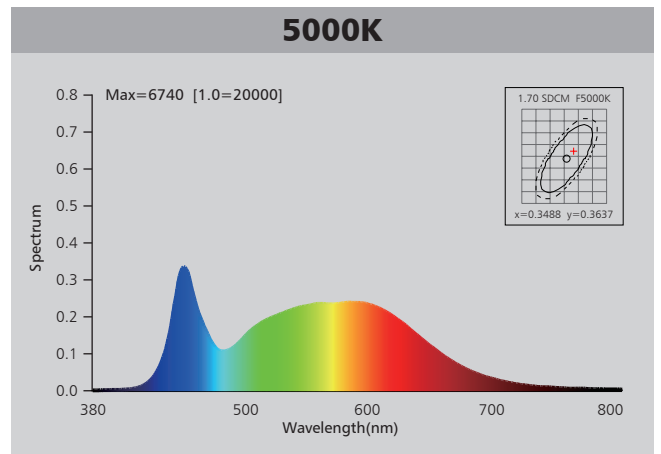
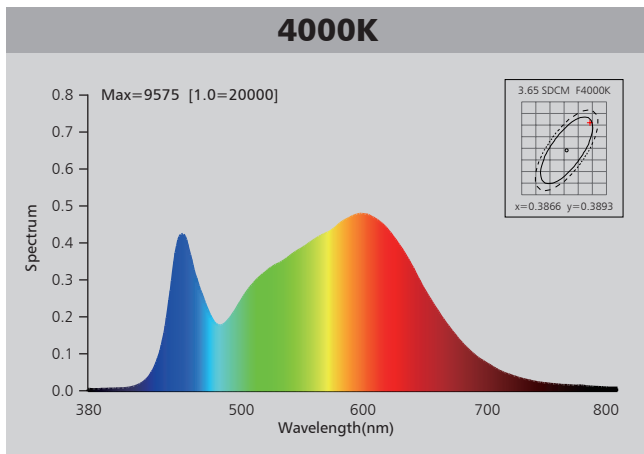
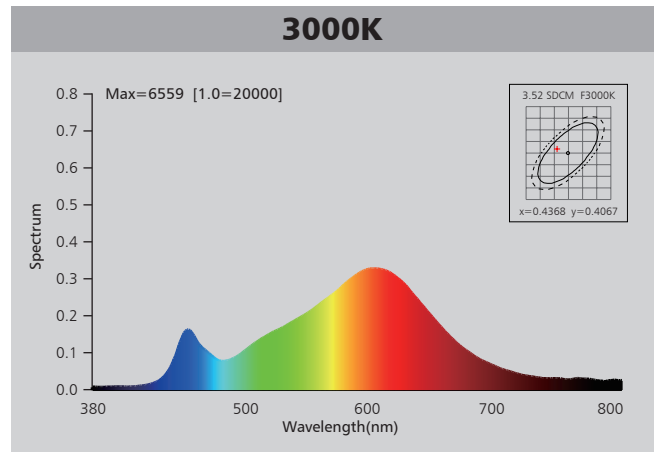
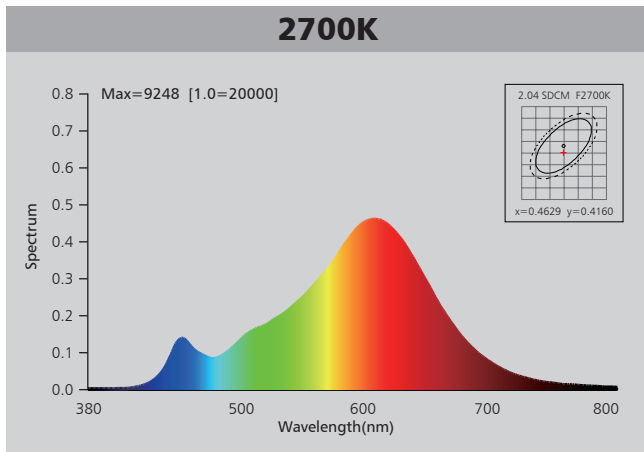

Photometric Diagram

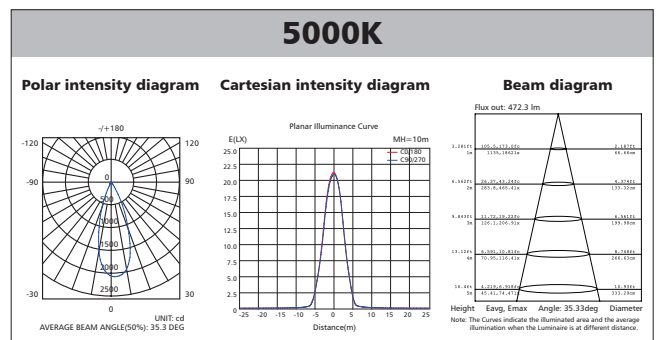
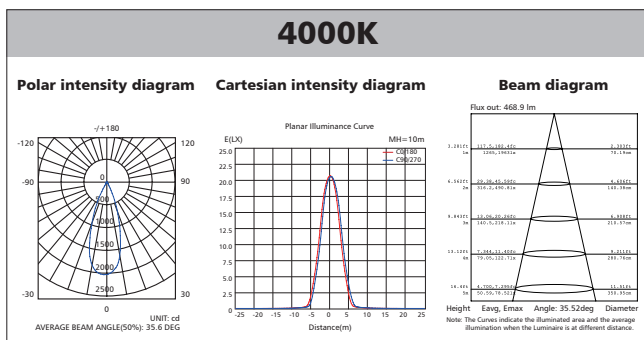
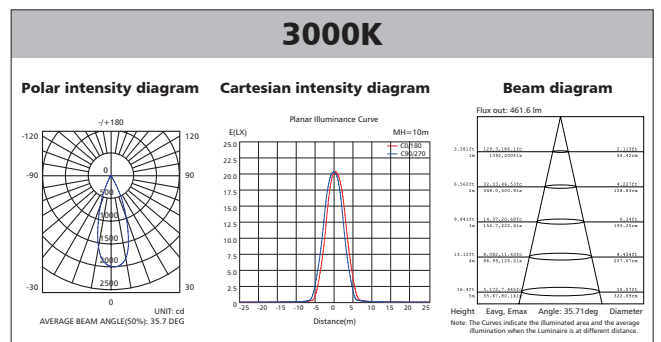
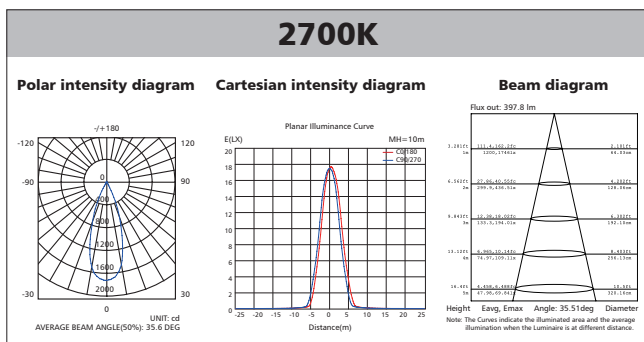

Polar Diagram Comparison

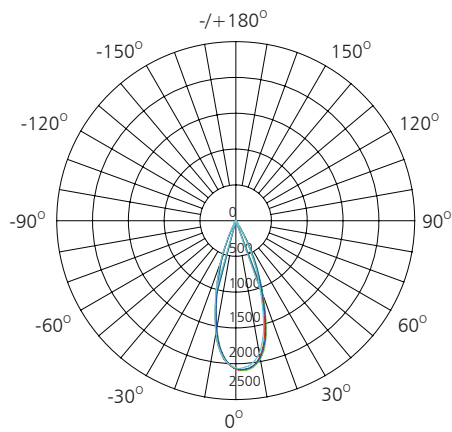

UNIT: cd

- C0/180, 35.2 deg
- C30/210, 35.4 deg
- C60/240, 35.4 deg
- C90/270, 35.3 deg



AVERAGE BEAM ANGLE (50%): 35.3DEG

Uncorrected UGR Table

ceiling/cavity	0.7	0.7	0.5	0.5	0.3	0.7	0.7	0.5	0.5	0.3		
walls	0.5	0.3	0.5	0.3	0.3	0.5	0.3	0.5	0.3	0.3		
working plane	0.2	0.2	0.2	0.2	0.2	0.2	0.2	0.2	0.2	0.2		
Room dimensions	Viewed crosswise					Viewed endwise						
x = 2H y = 2H	14.9	15.7	15.1	15.9	16.0	14.8	15.5	15.0	15.7	15.9		
3H	15.8	16.5	16.0	16.7	16.9	15.6	16.3	15.8	16.5	16.7		
4H	16.2	16.8	16.4	17.1	17.3	15.9	16.6	16.2	16.8	17.0		
6H	16.4	17.0	16.7	17.3	17.5	16.2	16.8	16.4	17.0	17.3		
8H	16.5	17.2	16.8	17.4	17.7	16.3	16.9	16.6	17.2	17.4		
12H	16.7	17.3	17.0	17.6	17.9	16.5	17.1	16.8	17.3	17.6		
4H	2H	15.2	15.9	15.5	16.1	16.3	15.1	15.8	15.4	16.0	16.2	
3H	16.3	16.9	16.6	17.2	17.4	17.4	16.1	16.7	16.4	17.0	17.3	
4H	16.8	17.4	17.2	17.7	18.0	18.0	16.6	17.1	16.9	17.4	17.7	
6H	17.2	17.6	17.5	18.0	18.3	18.3	16.9	17.4	17.3	17.7	18.1	
8H	17.3	17.8	17.7	18.1	18.5	18.5	17.1	17.6	17.5	17.9	18.3	
12H	17.6	18.0	18.0	18.4	18.8	18.8	17.4	17.8	17.8	18.2	18.6	
8H	4H	17.0	17.4	17.4	17.8	18.1	18.1	16.8	17.2	17.2	17.6	17.9
6H	17.4	17.8	17.8	18.2	18.6	18.6	17.2	17.6	17.6	18.0	18.4	
8H	17.7	18.0	18.2	18.5	18.9	18.9	17.5	17.8	18.0	18.3	18.7	
12H	18.2	18.4	18.6	18.9	19.3	19.3	18.0	18.2	18.4	18.7	19.1	
12H	4H	17.0	17.4	17.4	17.7	18.1	18.1	16.8	17.2	17.2	17.5	17.9
6H	17.4	17.8	17.9	18.2	18.6	18.6	17.3	17.6	17.7	18.0	18.4	
8H	17.8	18.1	18.3	18.5	19.0	19.0	17.6	17.9	18.1	18.3	18.8	
Variations with the observer position at spacings:												
S = 1.0H	+ 0.4 / - 0.5					+ 0.4 / - 0.6						
1.5H	+ 0.5 / - 0.4					+ 0.5 / - 0.4						
2.0H	+ 0.5 / - 0.5					+ 0.6 / - 0.5						

Driver lifetime & LED light decay rate

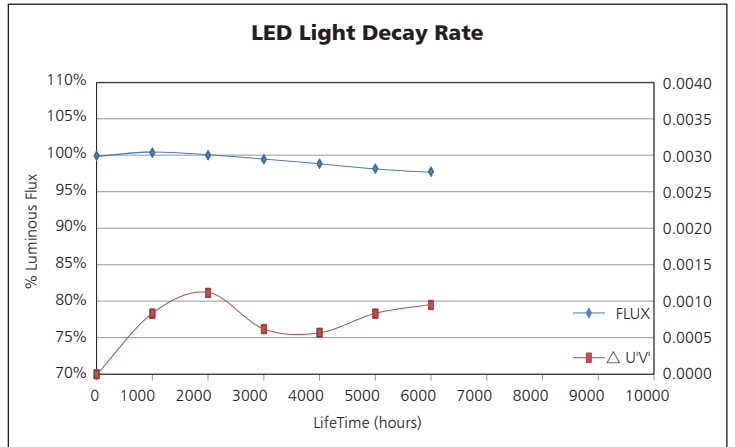
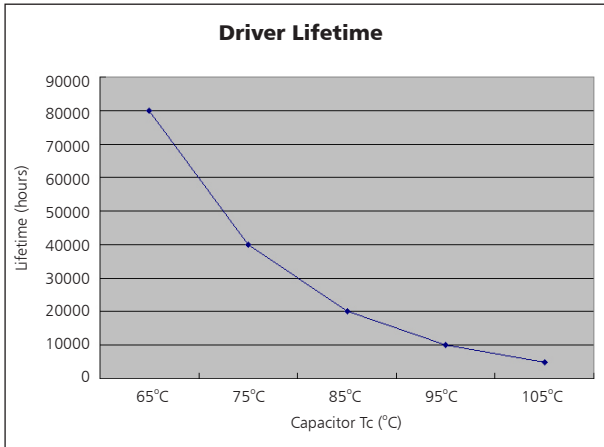

Temperature

- The testing is operated at 25°C
- The lifetime of capacitor, minimum of 5,000 hours if operated at 105°C, will be doubled whenever the temperature drops 10°C
- The highest withstand temperature of IC, MOS could be 120°C
- The highest withstand temperature of LED junction temperature is 150°C

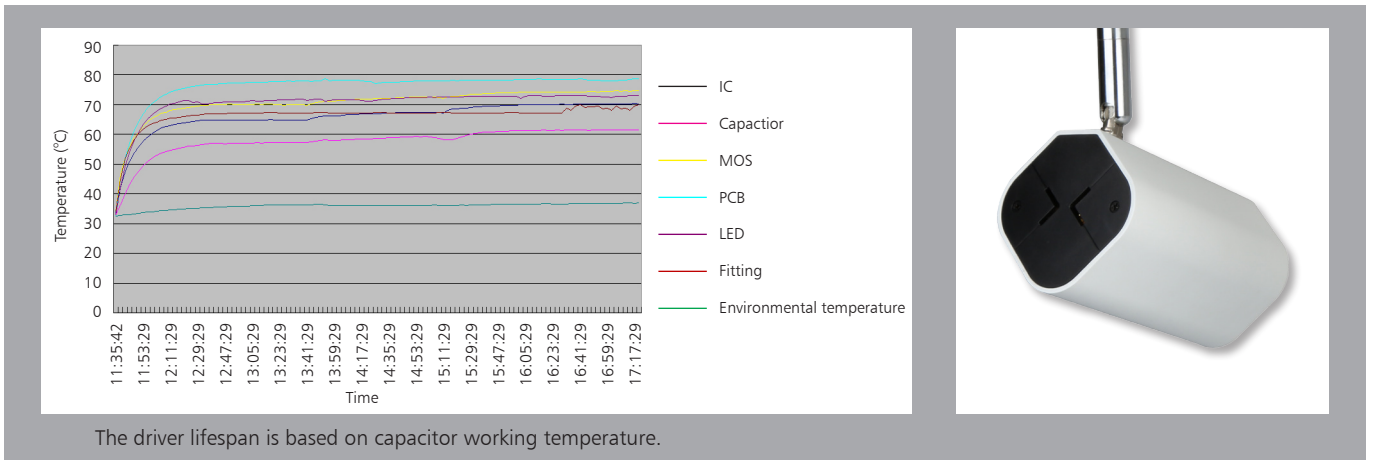

Installation (A)

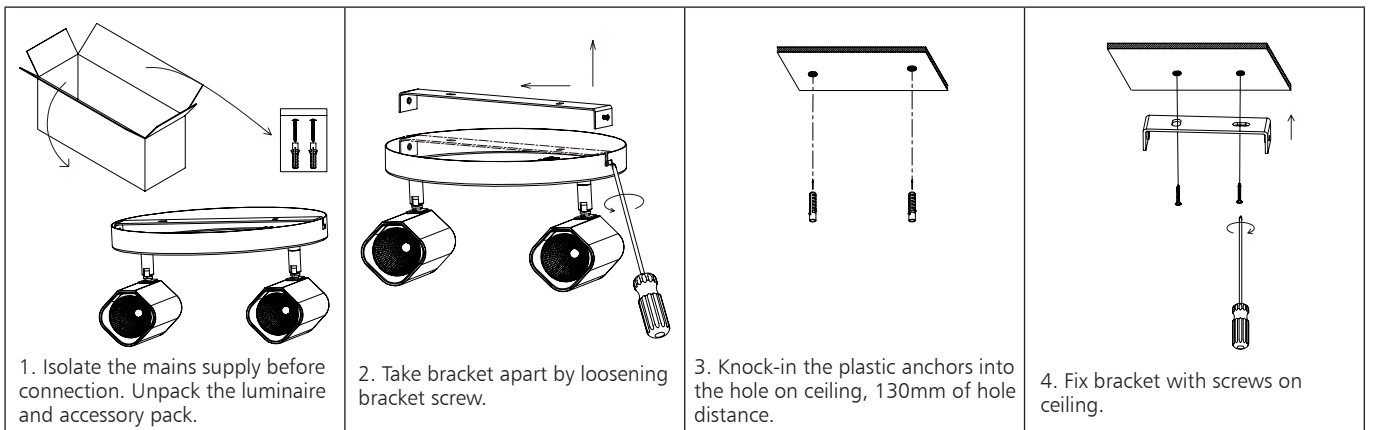

5. Feed mains cable "L", "N", "G" to terminal block respectively.

6. Fix ceiling spotlight to bracket on ceiling.

7. Fasten the bracket screw.

8. Restore power supply, switch on and test for correct operation. Lamp head adjustable if needed.

Installation (B)

1. Isolate the mains supply before connection. Unpack the luminaire and accessory pack.

2. Take bracket apart by loosening bracket screw.

3. Knock-in the plastic anchors into the hole on ceiling, 100mm of hole distance.

4. Fix bracket with screws on ceiling.

5. Feed mains cable "L", "N", "G" to terminal block respectively.

6. Fix ceiling spotlight to bracket on ceiling.

7. Fasten the bracket screw.

8. Restore power supply, switch on and test for correct operation. Lamp head adjustable if needed.

Packaging Information (A)

	SIZE(CM)	N.W/pc (KGS)	G.W.(KGS)	Q'TY(PCs)
Carton	55.5*55.5*49	0.84	13.7	12

	CTNS	Q'TY(PCs)	VOLUME(CBM)
20" standard container	184	2208	28
40" standard container	368	4416	56

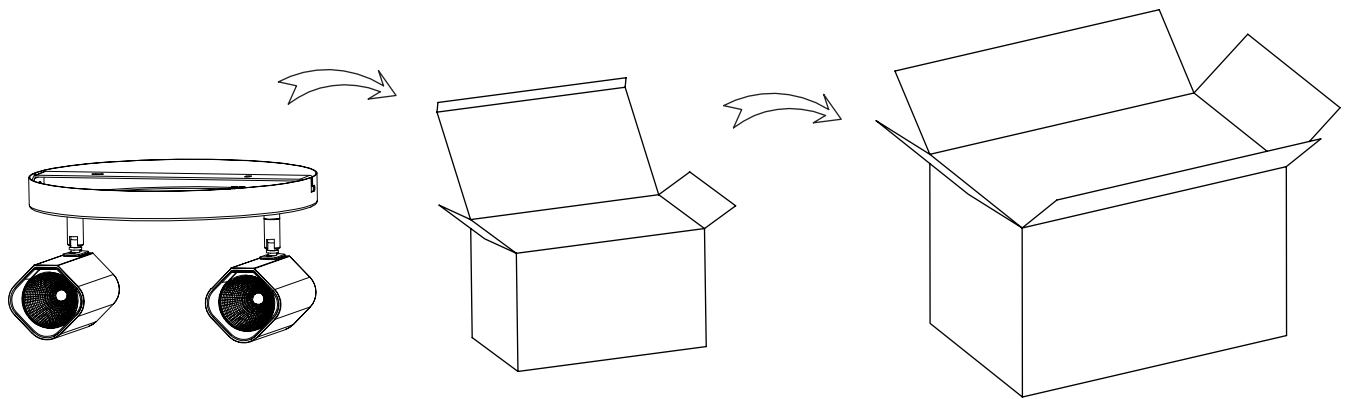

Packaging Information (B)

	SIZE(CM)	N.W/pc (KGS)	G.W.(KGS)	Q'TY(PCS)
Carton	64.5*31.5*33.5	1.3	17.5	12

	CTNS	Q'TY(PCS)	VOLUME(CBM)
20" standard container	405	4860	28
40" standard container	810	9720	56

