



Up-shine® Lighting



Technical Application Guide for UP-SHINE LED Spotlight

UP-TL20-30W

Introduction

UP-TL20A-30W

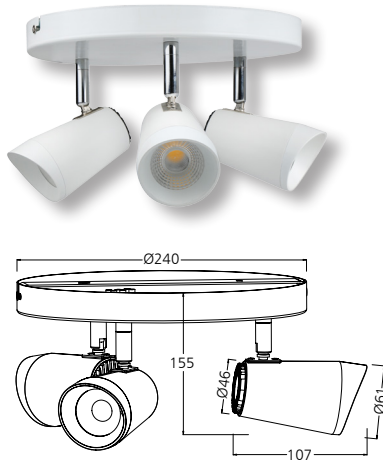

UP-TL20B-30W

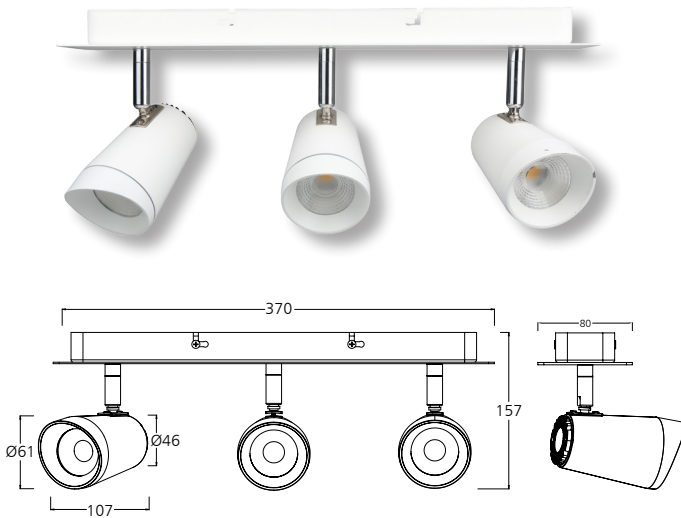

Up-shine ceiling spotlight adopts die-casting ADC12 with excellent heat dissipation. CRI80 and high efficient COB led chip to assure that high center luminous intensity. It is designed with high transmittance optical lens, maximum utilization of light output. Adjustable lighting orientation with 340 degree in horizontal direction and 0-90 degree in vertical direction. Dimmable available, compatible with a wide range of recommended Triac dimmers. Lamp with surface mounted installation, easy to install.

- Up to 70% energy saving compared to standard CFL
- Long lifetime of 40,000 hours
- 36°/60° beam angle
- CCT: 2700K 3000K
4000K 5000K
- No UV/IR light
- Environment friendly, without Mercury or any other hazardous substances

Application notes

- IP20 for indoor use only
- Professional electrician for installation only
- Switch off before installation
- Do not touch when in use
- Keep away from hot steam and corrosive gas

Application Areas

It is suitable for supermarket, specialty store, show window, exhibition hall; focus lighting, decorative and background lighting, where attention is focused on subjects to emphasize special visual points.

Certificate



Product Information

Technical Specifications

Power	Voltage	Power Factor	Lumen (±5%)	Beam angle	CCT	Lifespan	CRI	Dimmable
30W	AC100-240V	≥0.9	2760	36°/60°	2700K	40000h	≥80	No
30W	AC100-240V	≥0.9	2970	36°/60°	3000K	40000h	≥80	No
30W	AC100-240V	≥0.9	3120	36°/60°	4000K	40000h	≥80	No
30W	AC100-240V	≥0.9	3150	36°/60°	5000K	40000h	≥80	No
30W	AC230V	≥0.9	2850	36°/60°	2700K	40000h	≥80	Yes
30W	AC230V	≥0.9	2865	36°/60°	3000K	40000h	≥80	Yes
30W	AC230V	≥0.9	3030	36°/60°	4000K	40000h	≥80	Yes
30W	AC230V	≥0.9	3165	36°/60°	5000K	40000h	≥80	Yes

Driver data Sheet

Driver data	DIM	Non-dim
Input rated Voltage	AC230V	AC100-240V
Frequency	50Hz	50/60Hz
Input Voltage	AC200-240V	AC85-265V
Efficiency	≥79%	≥78%
Total load Wattage	3*10W±0.5W	3*10W±0.5W
Power Factor	≥0.9	≥0.9
Rated input current	≤3*0.06A	≤3*0.12A
Full load output Voltage	DC28-38V	DC23-40V
Rated output current	3*230mA	3*250mA
Output current range	3*230mA±5%	3*250mA±5%
Power tolerance	±5%	±5%
Current output tolerance	±5%	±5%
Dimming range	8%-100%	--
Dimmer	Triac dimmers	--
Short circuit protection	PASS	PASS
Over voltage protection	PASS	PASS
Over temperature protection	PASS	PASS
THD	<20%	<18%
Withstand voltage	AC1500V	AC1500V

Fixture Compatibility

Rated Wattage	Electrical Classification	Ingress Protection	Operating Temp	Operating Humidity	Storage Temp
30W	I	IP20	-20°C~45°C	0~90%	-20°C~65°C

Spectral Distribution

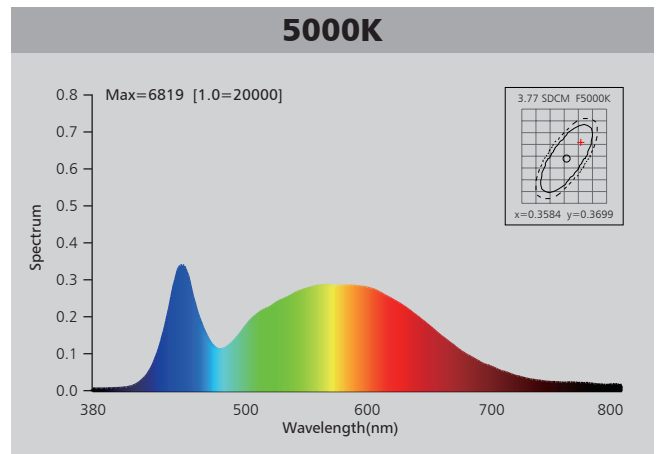
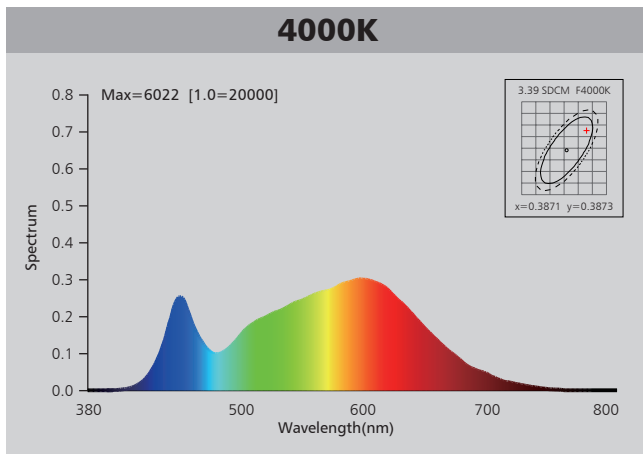
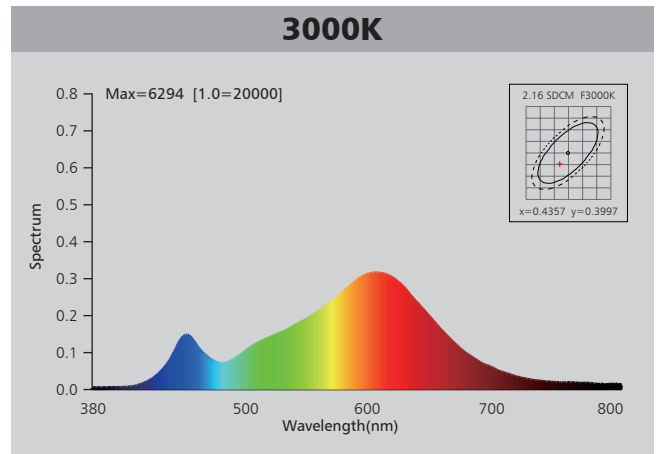
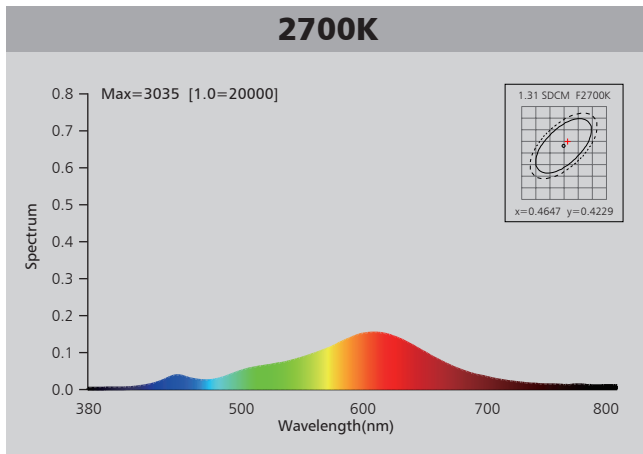

Photometric Diagram

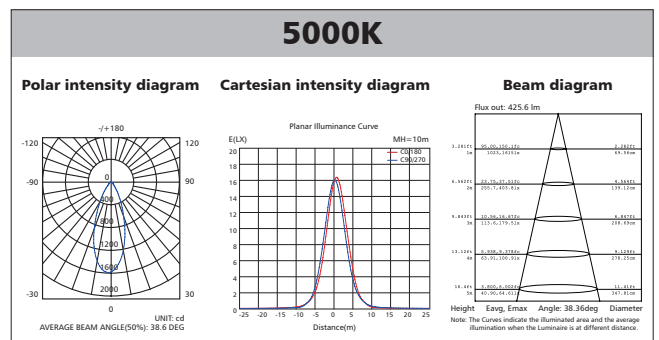
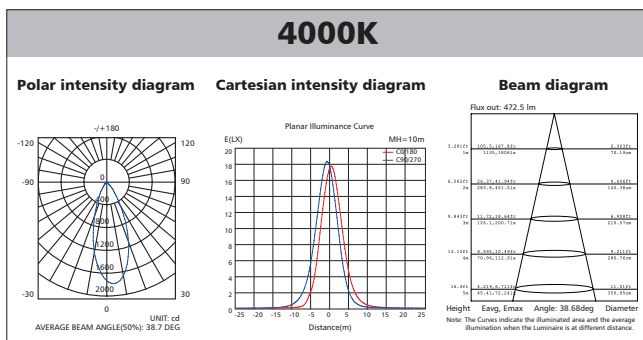
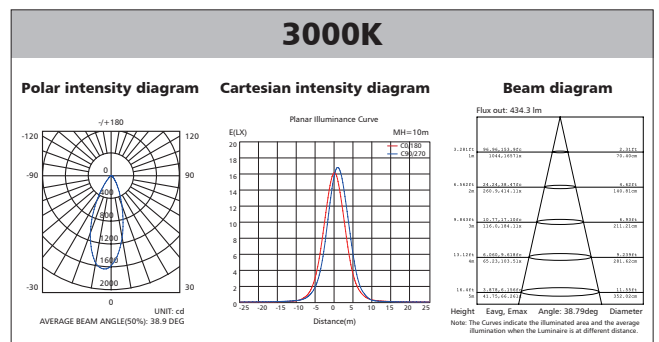
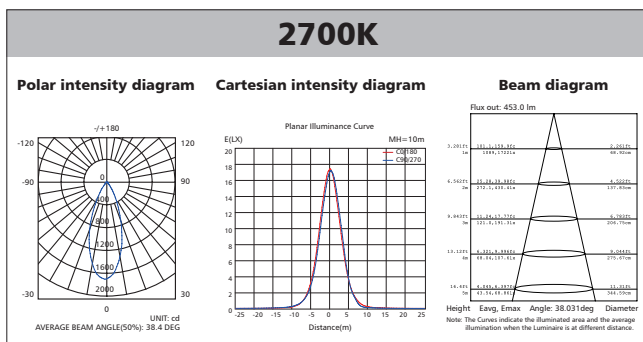

Polar Diagram Comparison

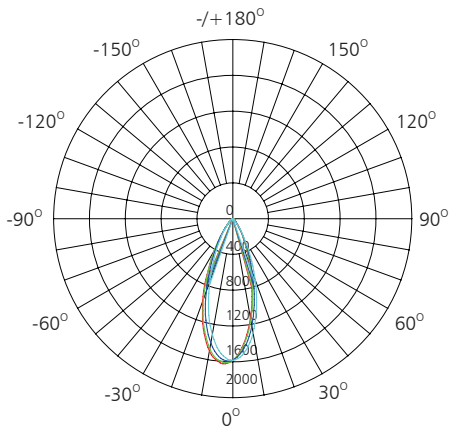

UNIT: cd

- C0/180, 38.4 deg
- C30/210, 38.6 deg
- C60/240, 38.7 deg
- C90/270, 38.6 deg

AVERAGE BEAM ANGLE (50%): 38.6DEG



Driver lifetime & LED light decay rate

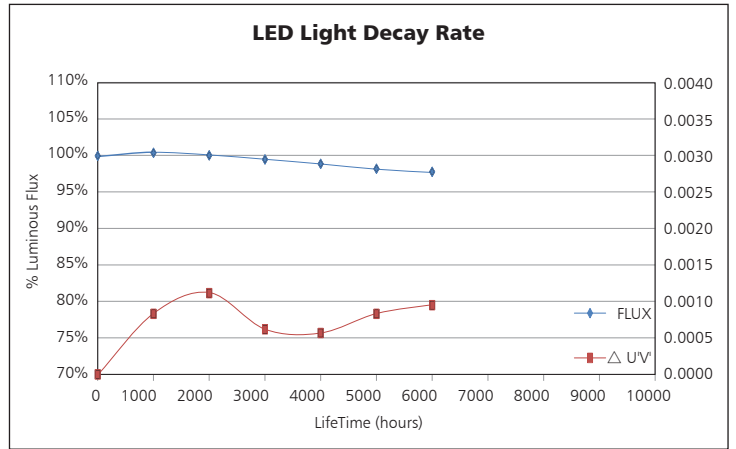
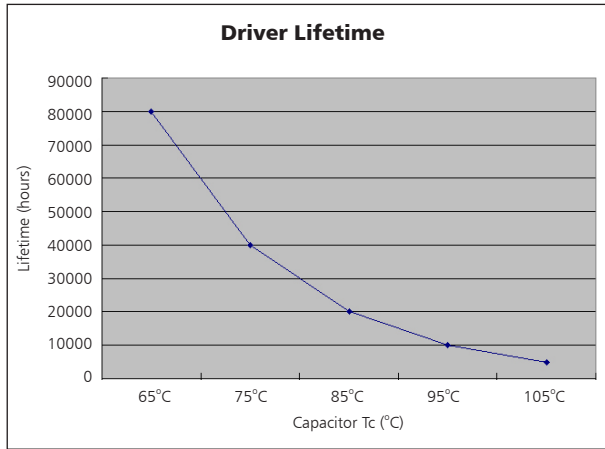

Temperature

- The testing is operated at 25°C
- The lifetime of capacitor, minimum of 5,000 hours if operated at 105°C, will be doubled whenever the temperature drops 10°C
- The highest withstand temperature of IC, MOS could be 120°C
- The highest withstand temperature of LED junction temperature is 150°C

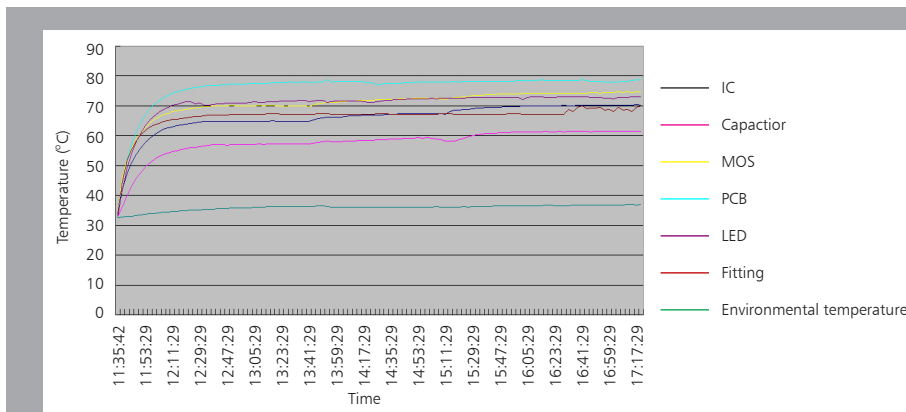

The driver lifespan is based on capacitor working temperature.

Installation (A)

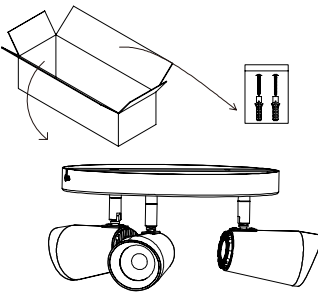
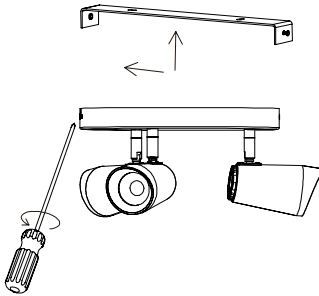
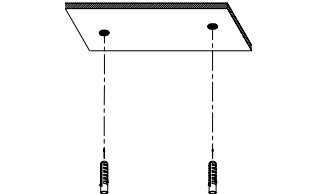
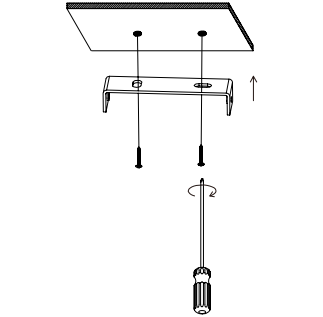
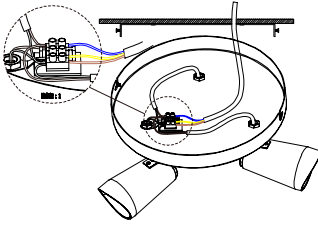
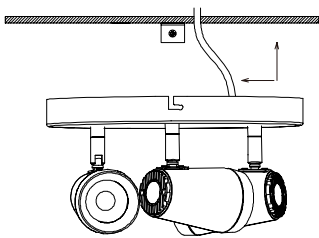
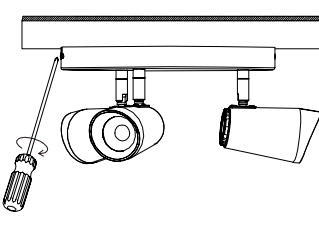
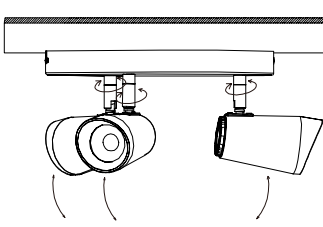
 <p>1. Isolate the mains supply before connection. Unpack the luminaire and accessory pack.</p>	 <p>2. Take bracket apart by loosening bracket screw.</p>	 <p>3. Knock-in the plastic anchors into the hole on ceiling, 130mm of hole distance.</p>	 <p>4. Fix bracket with screws on ceiling.</p>
 <p>5. Feed mains cable "L", "N", "G" to terminal block respectively.</p>	 <p>6. Fix ceiling spotlight to bracket on ceiling.</p>	 <p>7. Fasten the bracket screw.</p>	 <p>8. Restore power supply, switch on and test for correct operation. Lamp head adjustable if needed.</p>

Installation (B)

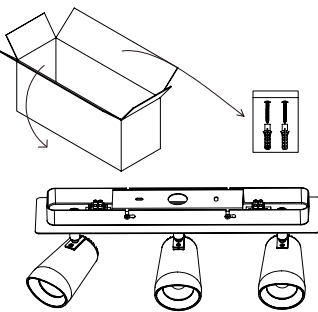
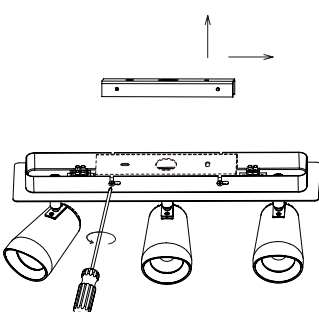
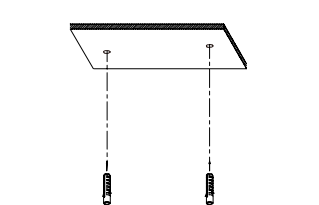
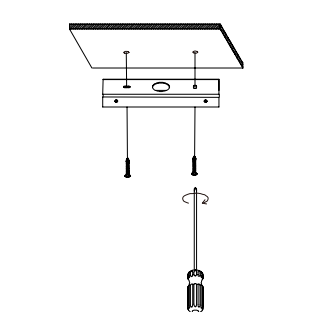
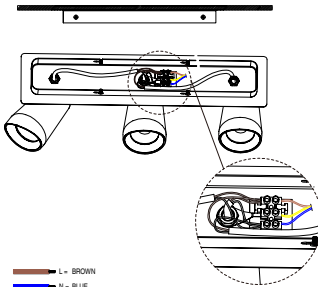
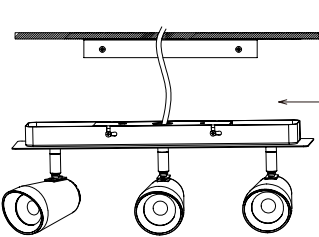
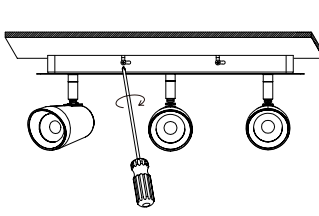
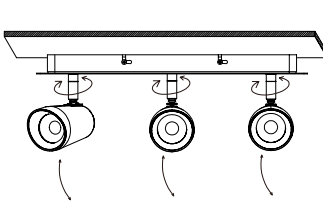
 <p>1. Isolate the mains supply before connection. Unpack the luminaire and accessory pack.</p>	 <p>2. Take bracket apart by loosening bracket screw.</p>	 <p>3. Knock-in the plastic anchors into the hole on ceiling, 100mm of hole distance.</p>	 <p>4. Fix bracket with screws on ceiling.</p>
 <p>5. Feed mains cable "L", "N", "G" to terminal block respectively.</p>	 <p>6. Fix ceiling spotlight to bracket on ceiling.</p>	 <p>7. Fasten the bracket screw.</p>	 <p>8. Restore power supply, switch on and test for correct operation. Lamp head adjustable if needed.</p>

Packaging Information (A)

	SIZE(CM)	N.W/pc (KGS)	G.W.(KGS)	Q'TY(PCS)
Carton	55.5*55.5*49	1.02	15.9	12

	CTNS	Q'TY(PCS)	VOLUME(CBM)
20" standard container	184	2208	28
40" standard container	368	4416	56

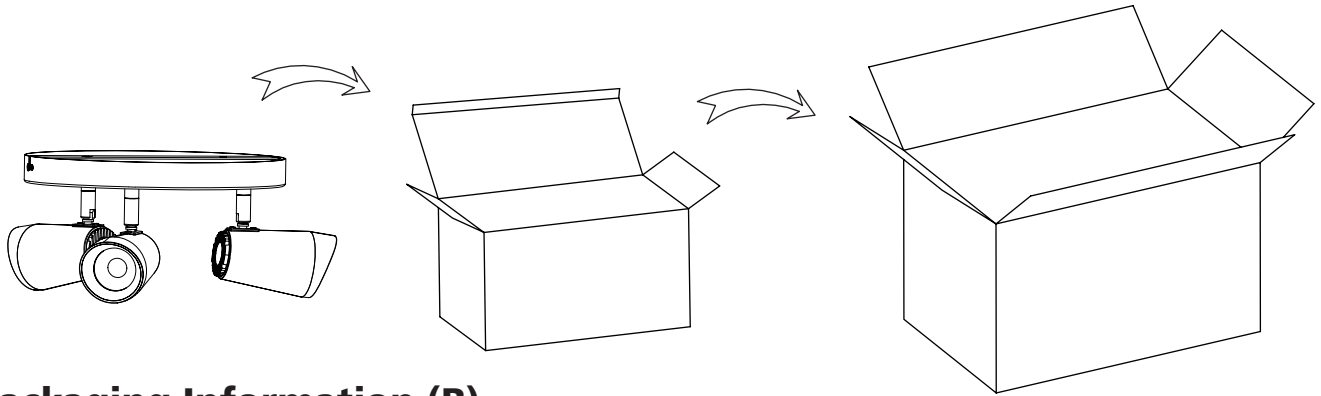

Packaging Information (B)

	SIZE(CM)	N.W/pc (KGS)	G.W.(KGS)	Q'TY(PCS)
Carton	45.5*41.5*49	1.28	17.6	12

	CTNS	Q'TY(PCS)	VOLUME(CBM)
20" standard container	299	3588	28
40" standard container	598	7176	56

