



UPSHINE®



# Technical Application Guide for UP-SHINE LED Track Light

UP-TL16-12W

# Introduction



Up-shine patent mini track lights with high CRI high lumen CITIZEN COB led chip to enhance color fidelity target illumination object. It offers excellent heat dissipation and even light output without glare or dark spot. Adjustable lighting orientation with 360 degree in horizontal direction and 180 in vertical direction provided. 1-circuit adapter, 3-circuit adapter are all available. With easy replacement of power deign, both non-dimmable and triac dimmable can be available, triac dimmable can be compatible with global brand dimmer.

- Up to 70% energy saving compared to standard CFL
- Long lifetime of 40,000 hours
- 15° / 24° / 36° / 60° beam angle
- CCT: 2700K 3000K  
4000K 5000K
- No UV/IR light
- Environment friendly, without Mercury or any other hazardous substances

## Application notes

- IP20 for indoor use only
- Professional electrician for installation only
- Switch off before installation
- Do not touch when in use
- Keep away from hot steam and corrosive gas

## Application Areas

It is suitable for supermarket, specialty store, show window, exhibition hall; focus lighting, decorative and background lighting, where attention is focused on subjects to emphasize special visual points.

## Certificate

CE RoHS SAA



# Product Information

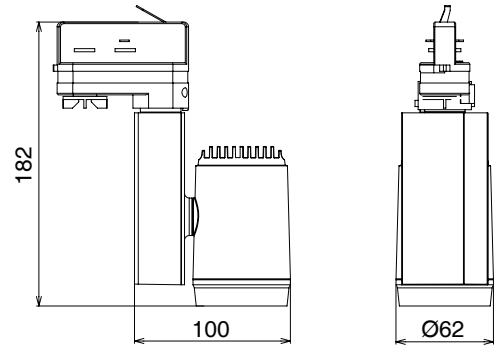

## Technical Specifications

Model	Voltage	Power	Power Factor	Lumen (±5%)	Beam angle	CCT	Lifespan	CRI	Dimmable	Dimension
UP-TL16-12W	AC100-240V	12W	≥0.9	1200	15° / 24° / 36° / 60°	2700K	40000h	≥80	No	62*100*182mm
UP-TL16-12W	AC100-240V	12W	≥0.9	1260	15° / 24° / 36° / 60°	3000K	40000h	≥80	No	62*100*182mm
UP-TL16-12W	AC100-240V	12W	≥0.9	1350	15° / 24° / 36° / 60°	4000K	40000h	≥80	No	62*100*182mm
UP-TL16-12W	AC100-240V	12W	≥0.9	1320	15° / 24° / 36° / 60°	5000K	40000h	≥80	No	62*100*182mm
UP-TL16-12W-D	AC230V	12W	≥0.9	1140	15° / 24° / 36° / 60°	2700K	40000h	≥80	Yes	62*100*182mm
UP-TL16-12W-D	AC230V	12W	≥0.9	1190	15° / 24° / 36° / 60°	3000K	40000h	≥80	Yes	62*100*182mm
UP-TL16-12W-D	AC230V	12W	≥0.9	1280	15° / 24° / 36° / 60°	4000K	40000h	≥80	Yes	62*100*182mm
UP-TL16-12W-D	AC230V	12W	≥0.9	1250	15° / 24° / 36° / 60°	5000K	40000h	≥80	Yes	62*100*182mm

## Driver data Sheet

Driver data	DIM	Non dim
Input rated Voltage	AC230V	AC100-240V
Frequency	50Hz	50/60Hz
Input Voltage	AC200-240V	AC85-265V
Efficiency	≥78%	≥85%
Total load Wattage	12W±1W	12W±1W
Power Factor	≥0.9	≥0.9
Rated input current	≤0.06A	≤0.14A
Full load output Voltage	DC35-40V	DC35-40V
Rated output current	250mA	280mA
Output current range	250mA±5%	280mA±5%
Power tolerance	±5%	±5%
Current output tolerance	±5%	±5%
Dimming range	8%-100%	----
Dimmer	Triac dimmers	----
Short circuit protection	PASS	PASS
Over voltage protection	PASS	PASS
Over temperature protection	PASS	PASS
Withstand voltage	AC1500V	AC1500V

## Fixture Compatibility

Rated Wattage	Electrical Classification	Ingress Protection	Operating Temp	Operating Humidity	Storage Temp
12W	I	IP20	-20°C~45°C	0~90%	-20°C~65°C

# Spectral Distribution

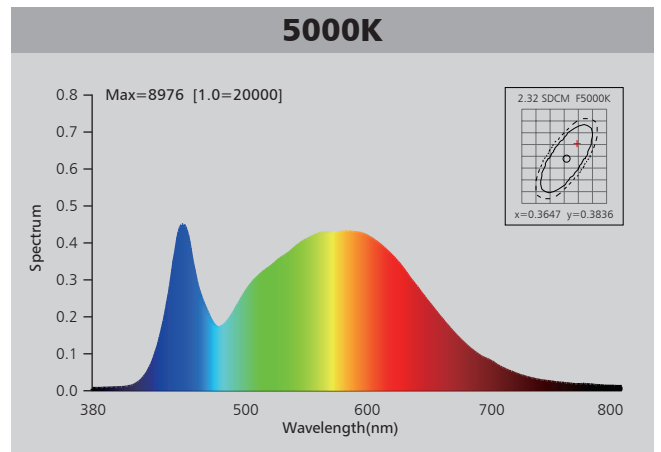
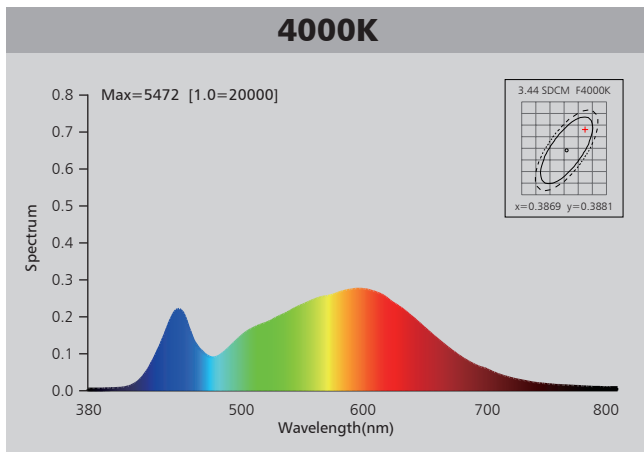
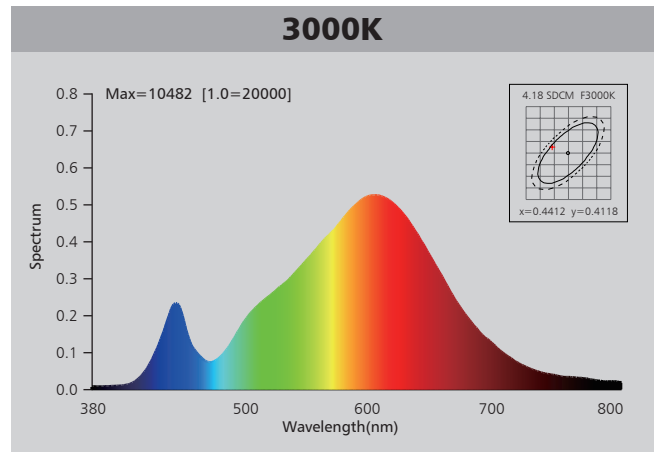
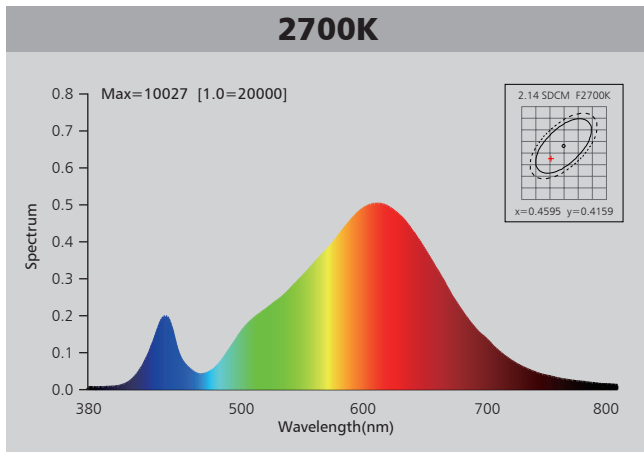

# Photometric Diagram

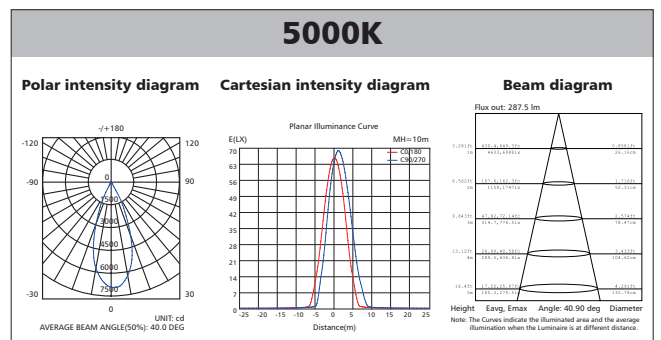
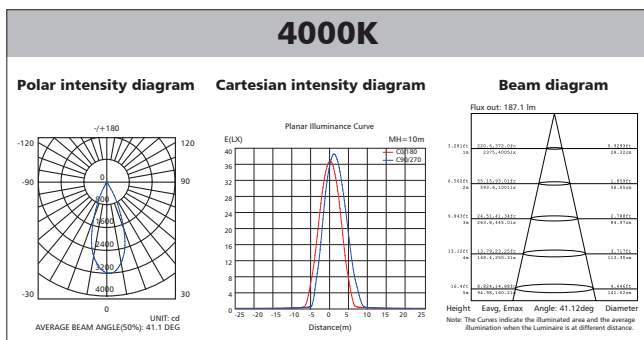
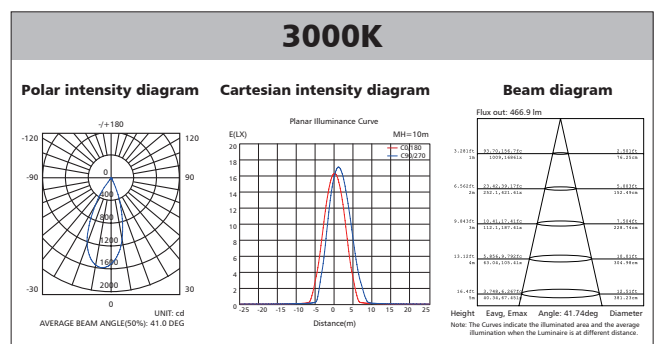
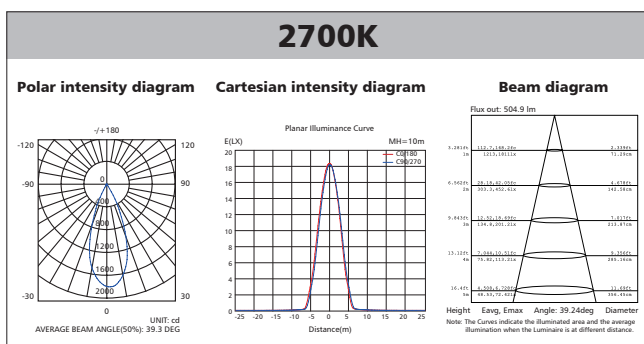

## Polar Diagram Comparison

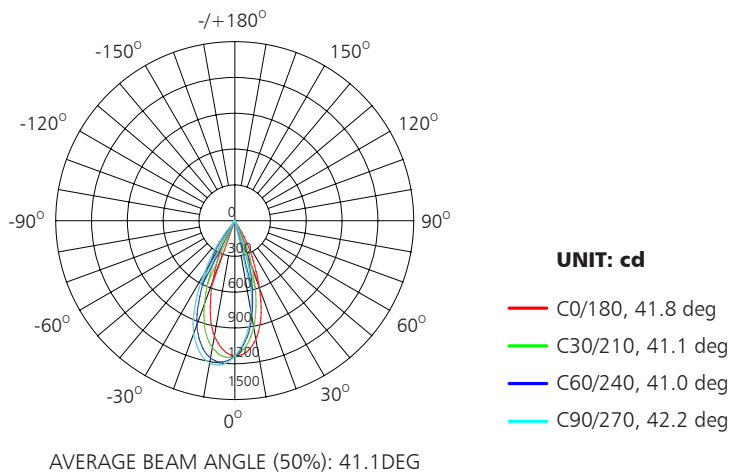

## Driver lifetime & LED light decay rate

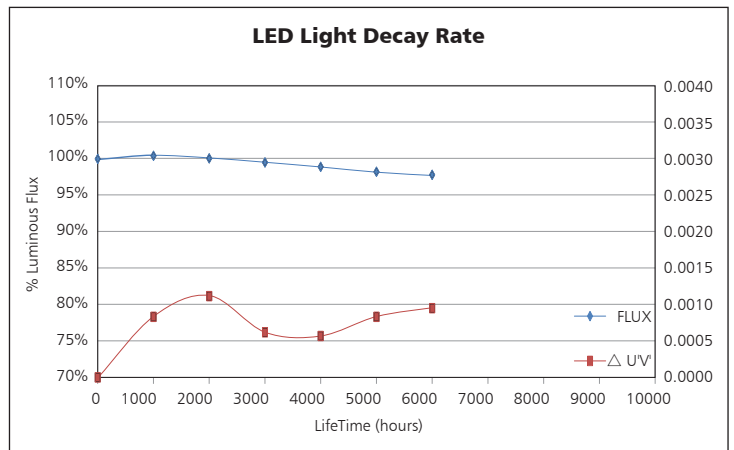
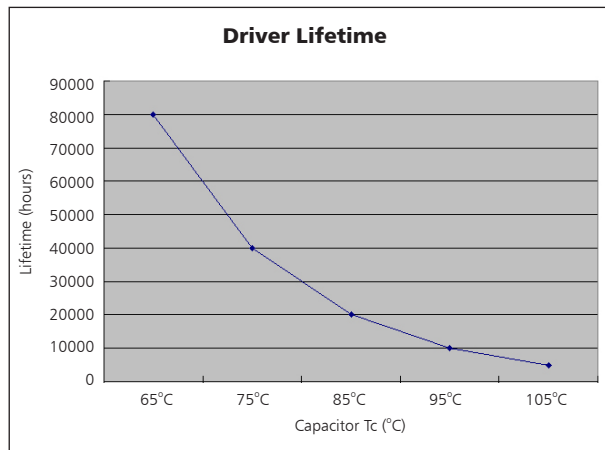

## Temperature

- The testing is operated at 25°C
- The lifetime of capacitor, minimum of 5,000 hours if operated at 105°C, will be doubled whenever the temperature drops 10°C
- The highest withstand temperature of IC, MOS could be 120°C
- The highest withstand temperature of LED junction temperature is 150°C

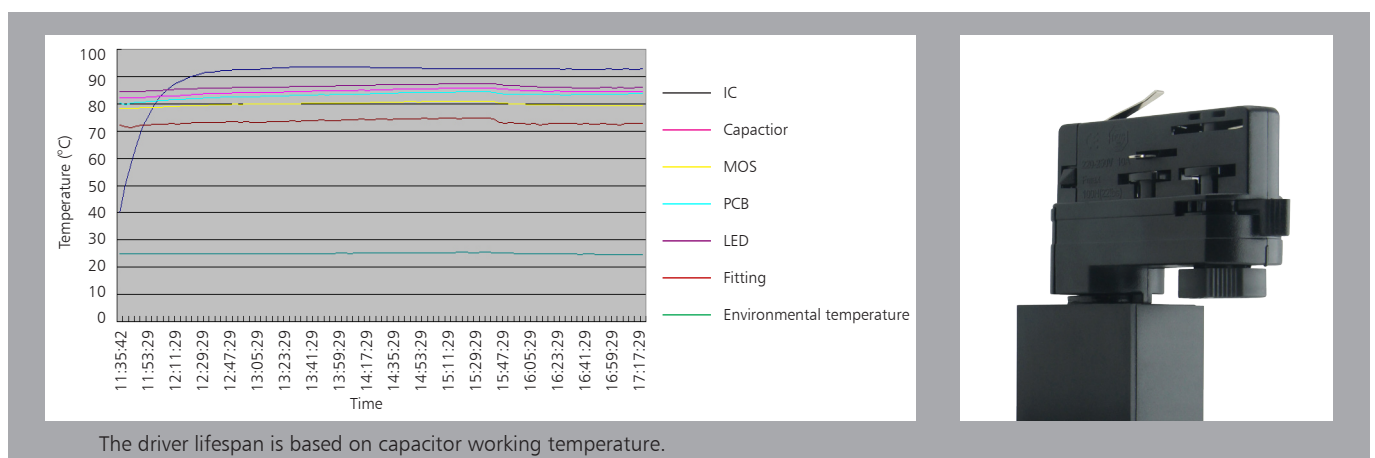

## Installation:

1. Switch off before installation, mount track to ceiling with mounting clips.
2. Connect track terminal block with "L", "N", "G" properly.
3. Insert fixture track adaptor into track making sure the two data bus contacts are on the same side as the data rail on the track. Follow 3 steps as below:
  - ① Align the adapter and contacts parallel with track
  - ② Pull down the latch on the adapter and insert the adapter into the track.  
(Note: Twist the adapter and ground contact toward the polarity groove.)
  - ③ Support the fixture with one hand and twist the adapter 1/4 turn till the latch locks into the track.
4. Adjust track light towards target object both vertically and horizontally. Switch on and test for correct operation.

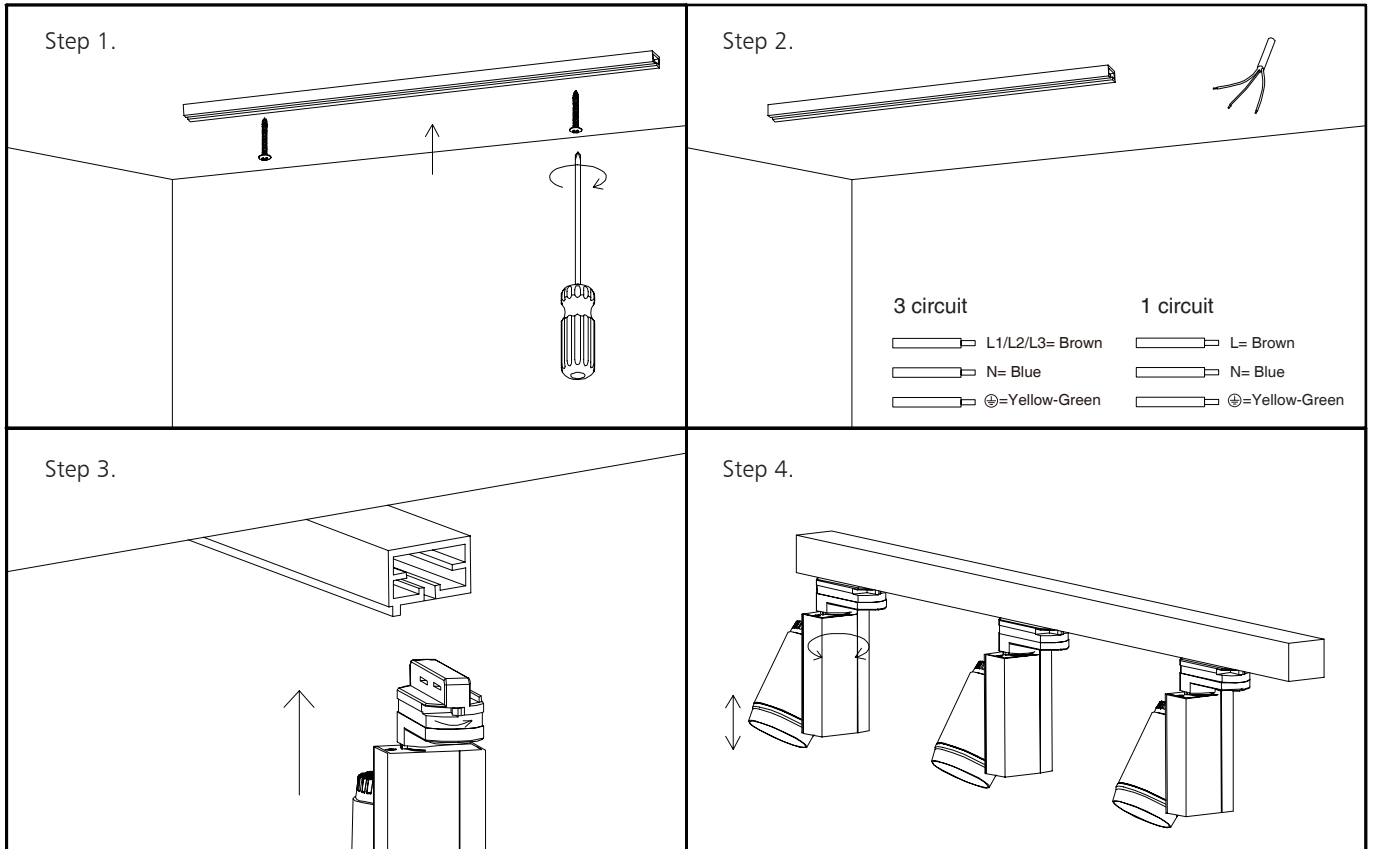

## Wiring Diagram:

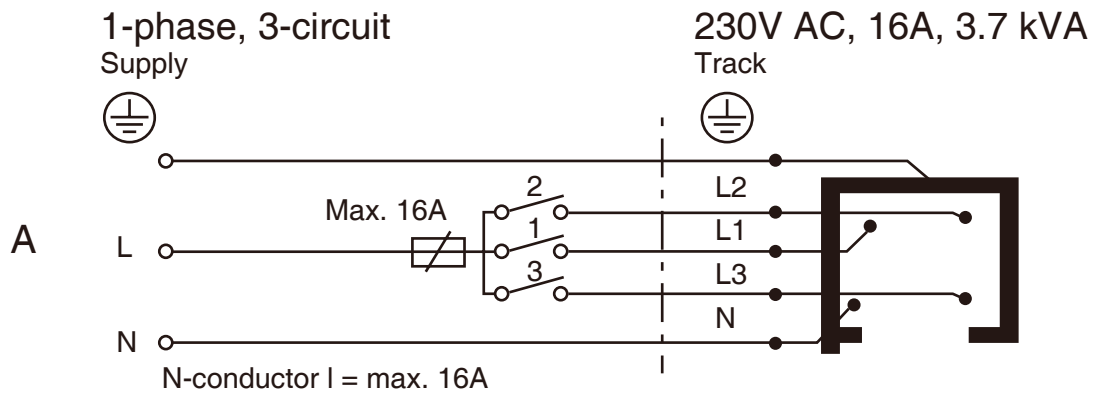

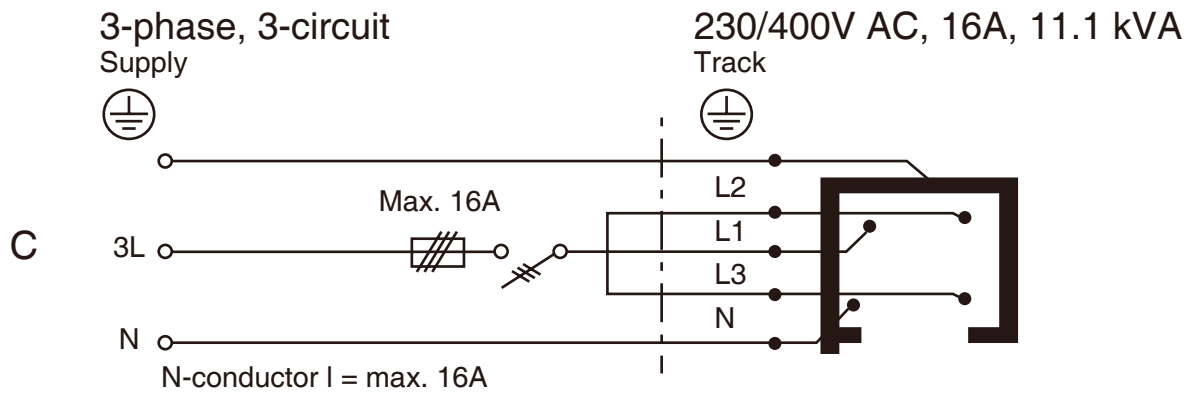
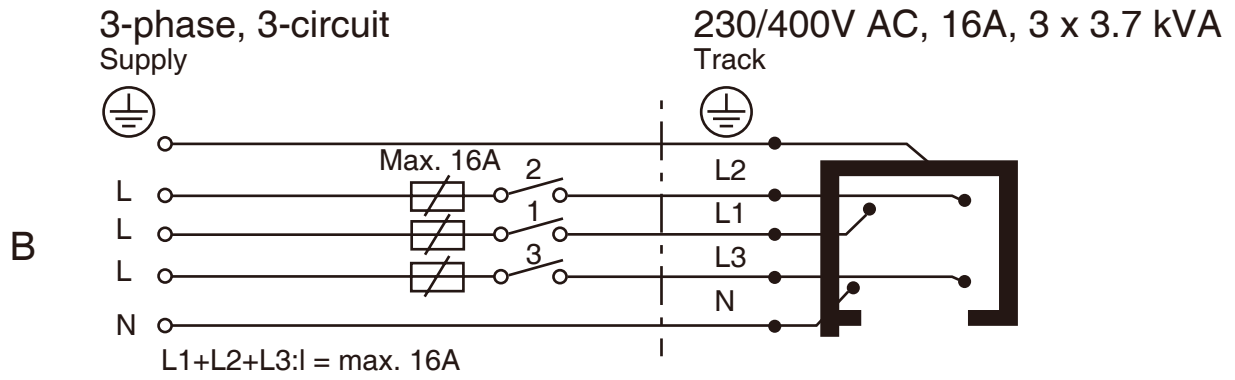

## Packaging Information

	SIZE(CM)	N.W/pc (KGS)	G.W.(KGS)	Q'TY(PCS)
Carton	48*58*33	0.46	11.5	20

	CTNS	Q'TY(PCS)	VOLUME(CBM)
20" standard container	301	6020	28
40" standard container	602	12040	56

