



Up-shine[®] Lighting



Technical Application
Guide for UP-SHINE
LED Ceiling Spotlight

UP-TL13B-10W

Introduction



Up-shine Ceiling Spotlight adopts die-casting ADC12 with excellent heat dissipation. CRI80 and high efficient COB led chip to assure that high center luminous intensity. It is designed with high transmittance glass, maximum utilization of light output. Adjustable lighting orientation with 350 degree in horizontal direction and 35 in vertical direction provided. Lamp with surface mounted installation, easy to install.

- Up to 70% energy saving compared to standard CFL
- Long lifetime of 40,000 hours
- 24°/36°/45°/60° beam angle
- CCT: 2700K 3000K
4000K 5000K
- No UV/IR light
- Environment friendly, without Mercury or any other hazardous substances

Application notes

- IP20 for indoor use only
- Professional electrician for installation only
- Switch off before installation
- Do not touch when in use
- Keep away from hot steam and corrosive gas

Application Areas

It is suitable for supermarket, specialty store, show window, exhibition hall; focus lighting, decorative and background lighting, where attention is focused on subjects to emphasize special visual points.

Certificate

CE RoHS



Product Information

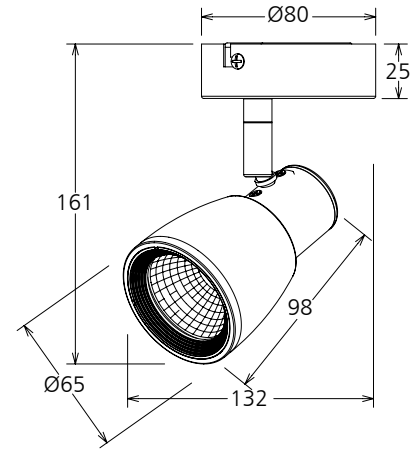

Technical Specifications

Model	Voltage	Power	Power Factor	Lumen (±5%)	Beam angle	CCT	Lifespan	CRI	Dimmable	Dimension
UP-TL13B-10W	AC100-240V	10W	≥0.9	750	24°/36°/45°/60°	2700K	40000h	≥80	No	Ø80*161mm
UP-TL13B-10W	AC100-240V	10W	≥0.9	760	24°/36°/45°/60°	3000K	40000h	≥80	No	Ø80*161mm
UP-TL13B-10W	AC100-240V	10W	≥0.9	800	24°/36°/45°/60°	4000K	40000h	≥80	No	Ø80*161mm
UP-TL13B-10W	AC100-240V	10W	≥0.9	780	24°/36°/45°/60°	5000K	40000h	≥80	No	Ø80*161mm
UP-TL13B-10W-D	AC230V	10W	≥0.9	690	24°/36°/45°/60°	2700K	40000h	≥80	Yes	Ø80*161mm
UP-TL13B-10W-D	AC230V	10W	≥0.9	700	24°/36°/45°/60°	3000K	40000h	≥80	Yes	Ø80*161mm
UP-TL13B-10W-D	AC230V	10W	≥0.9	740	24°/36°/45°/60°	4000K	40000h	≥80	Yes	Ø80*161mm
UP-TL13B-10W-D	AC230V	10W	≥0.9	720	24°/36°/45°/60°	5000K	40000h	≥80	Yes	Ø80*161mm

Driver data Sheet

Driver data	DIM	Non dim
Input rated Voltage	AC230V	AC100-240V
Frequency	50Hz	50/60Hz
Input Voltage	AC200-240V	AC85-265V
Efficiency	≥78%	≥85%
Total load Wattage	10W±0.5W	10W±0.5W
Power Factor	≥0.9	≥0.9
Rated input current	≤0.06A	≤0.12A
Full load output Voltage	DC35-38V	DC24-38V
Rated output current	215mA	230mA
Output current range	215mA±5%	230mA±5%
Power tolerance	±5%	±5%
Current output tolerance	±5%	±5%
Dimming range	8%-100%	—
Dimmer	Triac dimmers	—
Short circuit protection	PASS	PASS
Over voltage protection	PASS	PASS
Over temperature protection	PASS	PASS
THD	<18%	<18%
Withstand voltage	AC1500V	AC1500V

Fixture Compatibility

Rated Wattage	Electrical Classification	Ingress Protection	Operating Temp	Operating Humidity	Storage Temp
10W	I	IP20	-20°C~45°C	0~90%	-20°C~65°C

Spectral Distribution

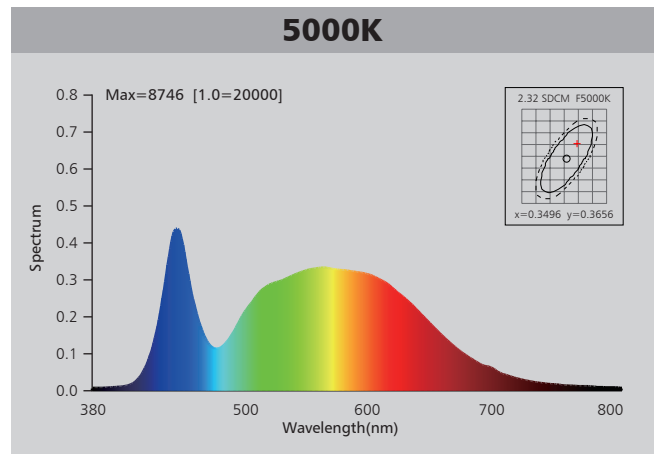
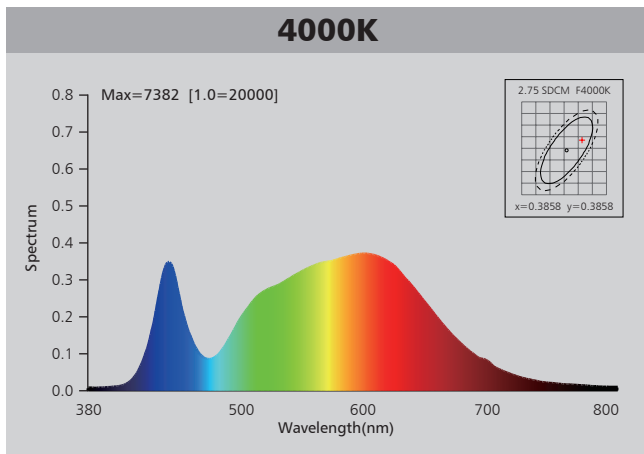
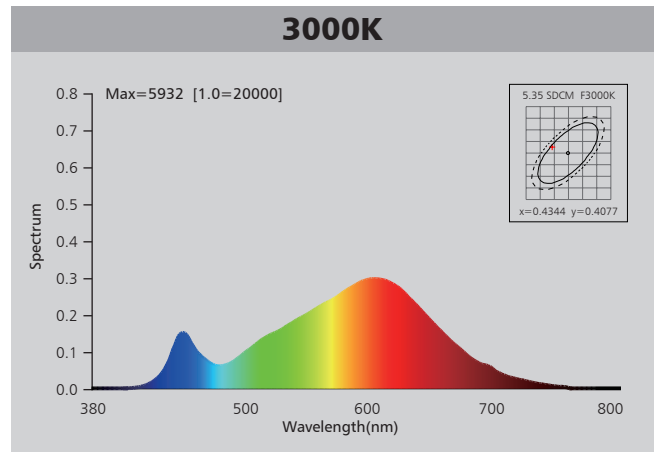
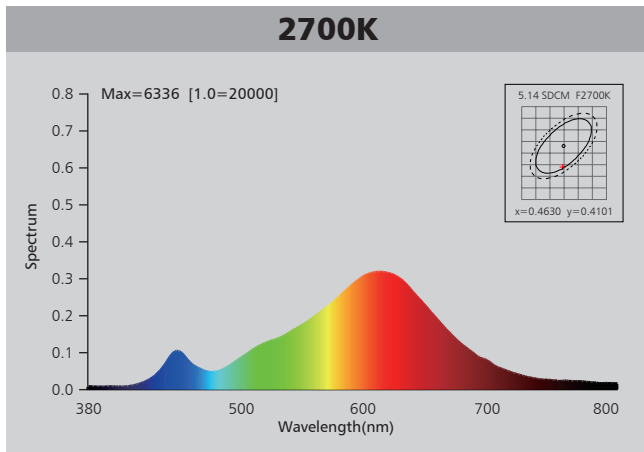

Photometric Diagram

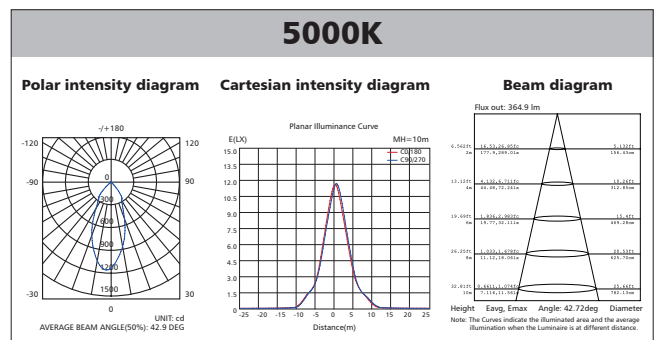
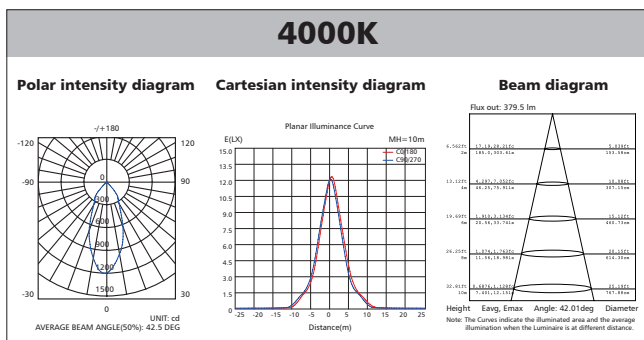
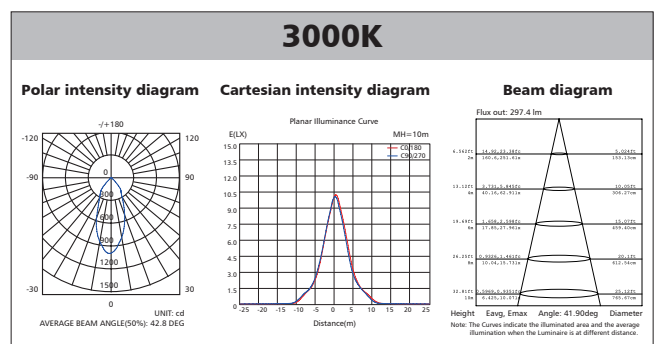
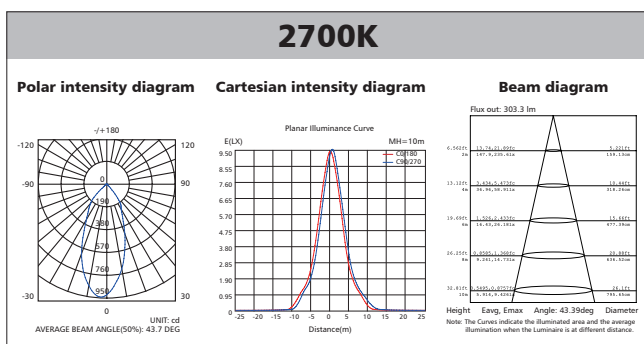

Polar Diagram Comparison

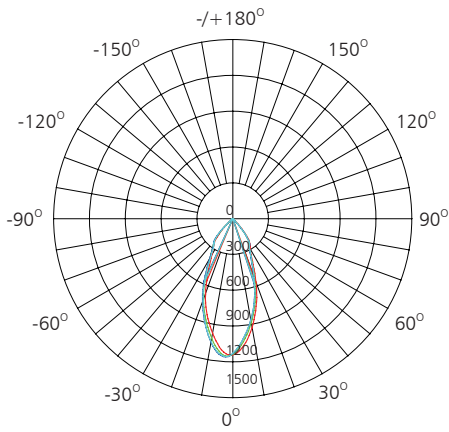

UNIT: cd

- C0/180, 42.8 deg
- C30/210, 43.1 deg
- C60/240, 43.0 deg
- C90/270, 42.8 deg

AVERAGE BEAM ANGLE (50%): 42.9DEG



Driver lifetime & LED light decay rate

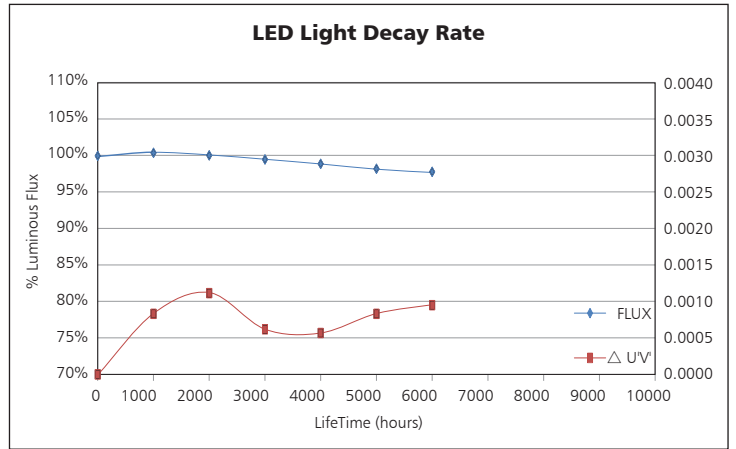
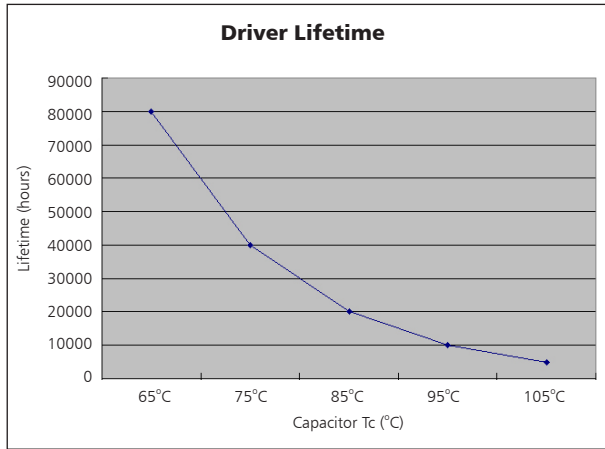

Temperature

- The testing is operated at 25°C
- The lifetime of capacitor, minimum of 5,000 hours if operated at 105°C, will be doubled whenever the temperature drops 10°C
- The highest withstand temperature of IC, MOS could be 120°C
- The highest withstand temperature of LED junction temperature is 150°C

Time	IC	Capacitor	MOS	PCB	LED	Fitting	Environmental temperature
11:35:42	35	35	35	35	35	35	35
11:53:29	65	65	65	65	65	65	35
12:11:29	70	70	70	70	70	70	35
12:29:29	75	75	75	75	75	75	35
12:47:29	75	75	75	75	75	75	35
13:05:29	75	75	75	75	75	75	35
13:23:29	75	75	75	75	75	75	35
13:41:29	75	75	75	75	75	75	35
13:59:29	75	75	75	75	75	75	35
14:17:29	75	75	75	75	75	75	35
14:35:29	75	75	75	75	75	75	35
14:53:29	75	75	75	75	75	75	35
15:11:29	75	75	75	75	75	75	35
15:29:29	75	75	75	75	75	75	35
15:47:29	75	75	75	75	75	75	35
16:05:29	75	75	75	75	75	75	35
16:23:29	75	75	75	75	75	75	35
16:41:29	75	75	75	75	75	75	35
16:59:29	75	75	75	75	75	75	35
17:17:29	75	75	75	75	75	75	35

The driver lifespan is based on capacitor working temperature.

www.upshine.com info@upshine.com

Installation

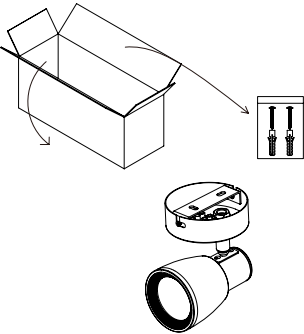
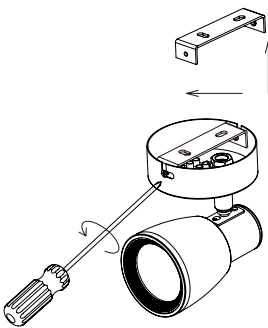
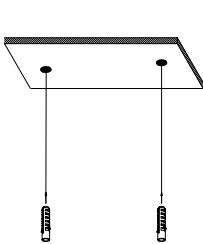
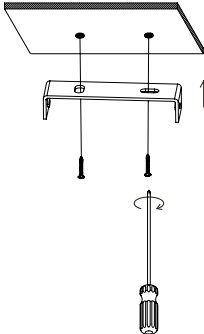
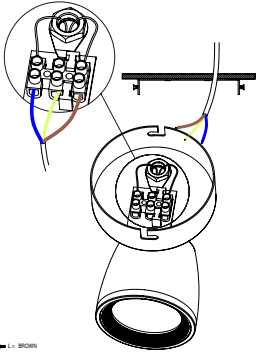
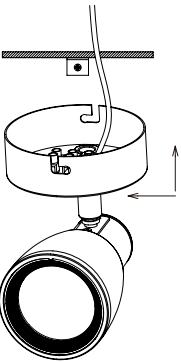
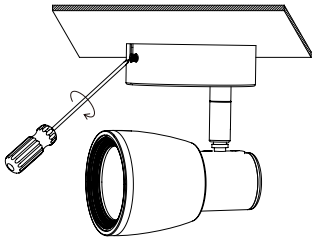
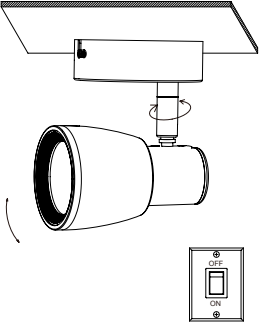
 <p>1. Isolate the mains supply before connection. Unpack the luminaire and accessory pack.</p>	 <p>2. Take bracket apart by loosening bracket screw.</p>	 <p>3. Knock-in the plastic anchors into the hole on ceiling, 70mm of hole distance.</p>	 <p>4. Fix bracket with screws on ceiling.</p>
 <p>5. Feed mains cable "L", "N", "G" to terminal block respectively.</p> <p> — L - BROWN — N - BLUE — G - YELLOW-GREEN </p>	 <p>6. Fix ceiling spotlight light to bracket on ceiling.</p>	 <p>7. Fasten the bracket screw.</p>	 <p>8. Restore power supply, switch on and test for correct operation. Lamp head adjustable if needed.</p>

Packaging Information

	SIZE(CM)	N.W/pc (KGS)	G.W.(KGS)	Q'TY(PCS)
Carton	41.5*38.5*49	0.32	10.6	24

	CTNS	Q'TY(PCS)	VOLUME(CBM)
20' standard container	353	8472	28
40' standard container	706	16944	56

