



Up-shine<sup>®</sup> Lighting



# Technical Application Guide for UP-SHINE LED Spotlight

UP-SP48-GU10-7W-D

# Introduction



LED Spotlight adopts high lumen LED, with high brightness and slight light decay. Excellent heat dissipation with aluminum heatsink and good color rendering index up to 80. MR16, GU10 base available, easy installation, with direct replacement of the traditional halogen. Dimmable version achieves great compatibility to worldwide famous brand dimmers.

- Up to 70% energy saving compared to halogen lamp
- Long lifetime of 40,000 hours
- Dimmable when using triac dimmer
- 38° beam angle
- Standard 50mm diameter
- CCT: 2700K 3000K  
4000K 5000K
- No UV/IR light
- Environment friendly, without Mercury or any other hazardous substances

## Application notes

- IP20 for indoor use
- Professional electrician for installation only
- Switch off before installation
- Do not touch when in use
- Keep away from hot steam and corrosive gas

## Application Areas

Application: It is widely used in residential lighting, such as bedroom, living room dining room, kitchen etc. Also commercial lighting, like hotel, restaurant, bar, shops etc.

## Certificates

**CE** **RoHS**



# Product Information

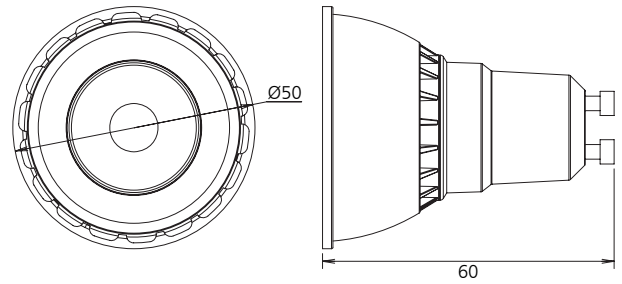

## Technical Specifications

Model	Voltage	Power	Power Factor	Lumen (±5%)	Beam angle	CCT	Lifespan	CRI	Dimmable	Dimension
UP-SP48-GU10-7W-D	AC230V	7W	≥0.9	560	38°	2700K	40000h	≥80	Yes	Ø50*60mm
UP-SP48-GU10-7W-D	AC230V	7W	≥0.9	575	38°	3000K	40000h	≥80	Yes	Ø50*60mm
UP-SP48-GU10-7W-D	AC230V	7W	≥0.9	565	38°	4000K	40000h	≥80	Yes	Ø50*60mm
UP-SP48-GU10-7W-D	AC230V	7W	≥0.9	645	38°	5000K	40000h	≥80	Yes	Ø50*60mm

## Driver data Sheet

Driver data	DIM
Input rated Voltage	AC230V
Frequency	50Hz
Input Voltage	AC200-240V
Efficiency	≥80%
Total load Wattage	7W±0.5W
Power Factor	≥0.9
Rated input current	≤0.04A
Full load output Voltage	DC33-38V
Rated output current	160mA
Output current range	160mA±5%
Power tolerance	±5%
Current output tolerance	±5%
Dimming range	8%-100%
Dimmer	Triac dimmers
Short circuit protection	PASS
Over voltage protection	PASS
Over temperature protection	PASS
Withstand voltage	AC3000V

## Fixture Compatibility

Rated Wattage	Electrical Classification	Ingress Protection	Operating Temp	Operating Humidity	Storage Temp
7W	II	IP20	-20°C~45°C	0~90%	-20°C~65°C

# Spectral Distribution

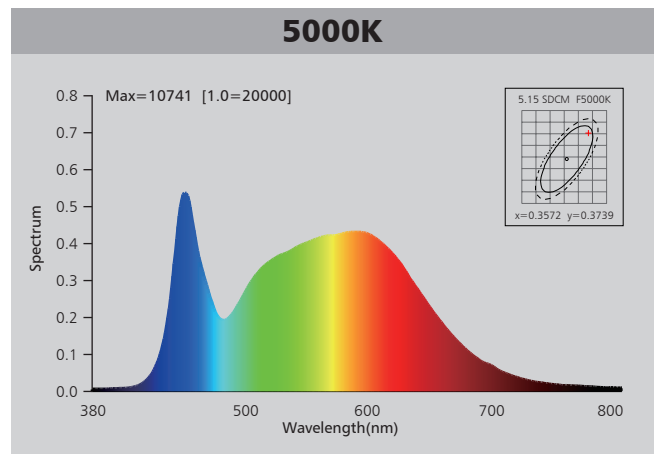
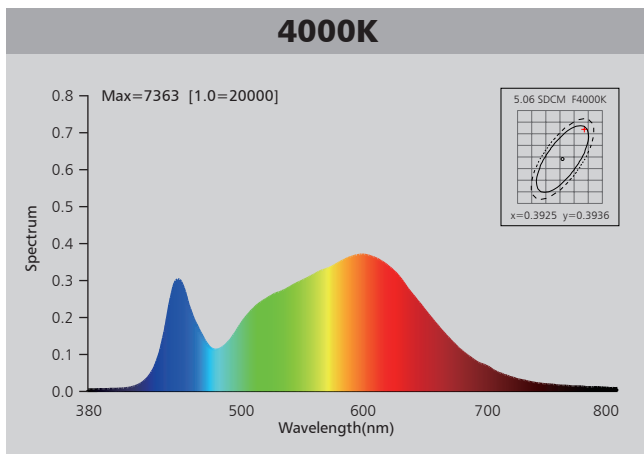
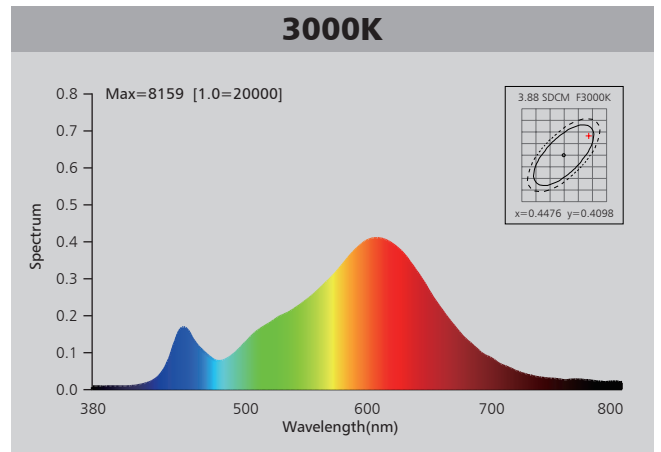
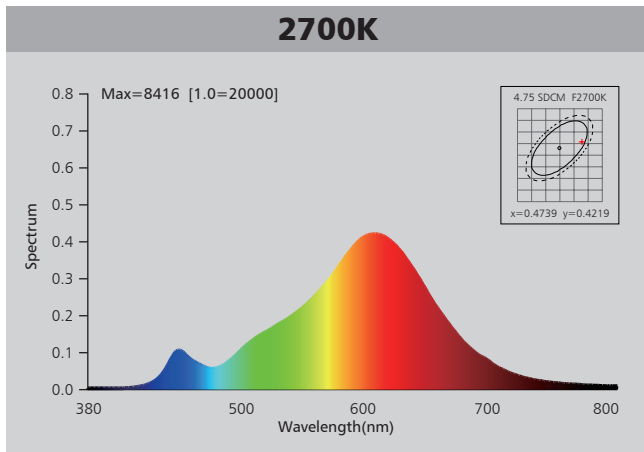

# Photometric Diagram

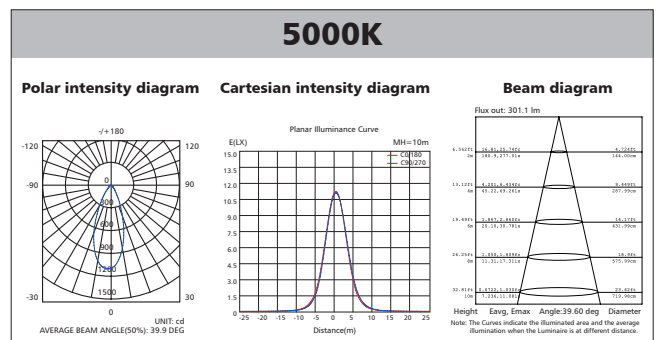
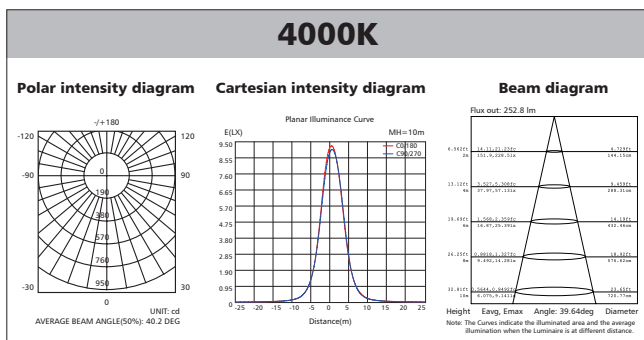
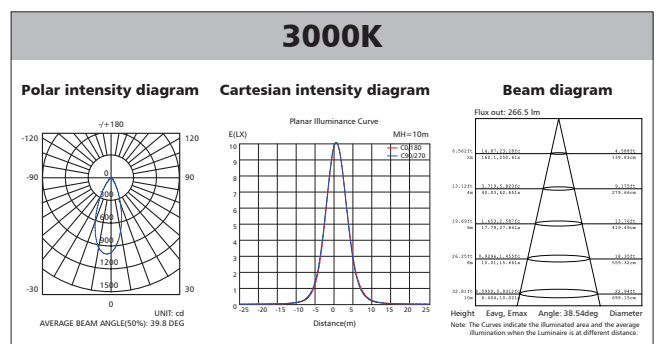
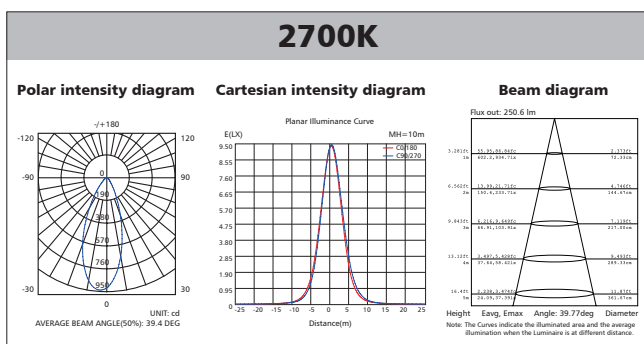

## Polar Diagram Comparison

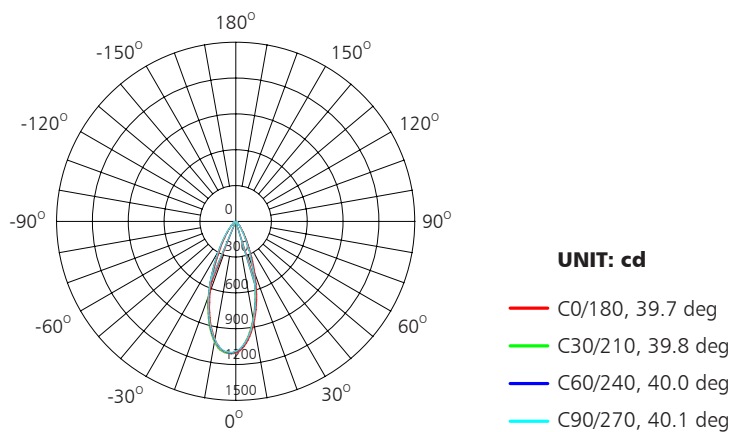

AVERAGE BEAM ANGLE (50%): 39.9DEG



## Driver lifetime & LED light decay rate

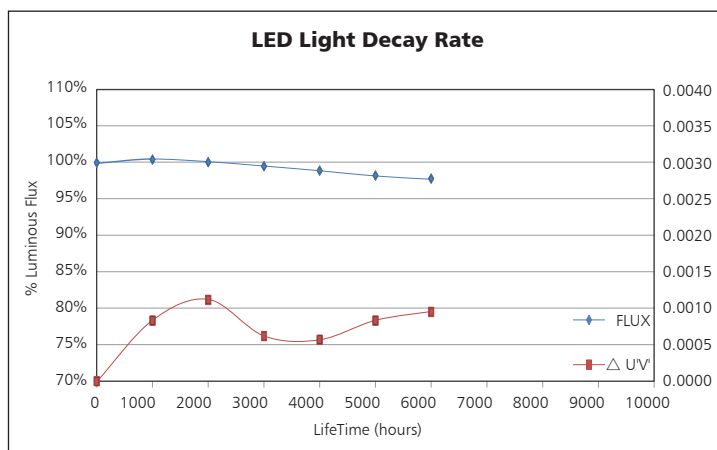
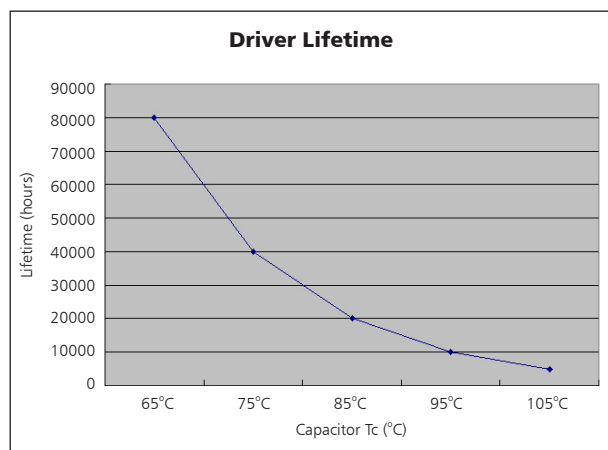

## Temperature

- The testing is operated at 25°C
- The lifetime of capacitor, minimum of 5,000 hours if operated at 105°C, will be doubled whenever the temperature drops 10°C
- The highest withstand temperature of IC, MOS could be 120°C
- The highest withstand temperature of LED junction temperature is 150°C

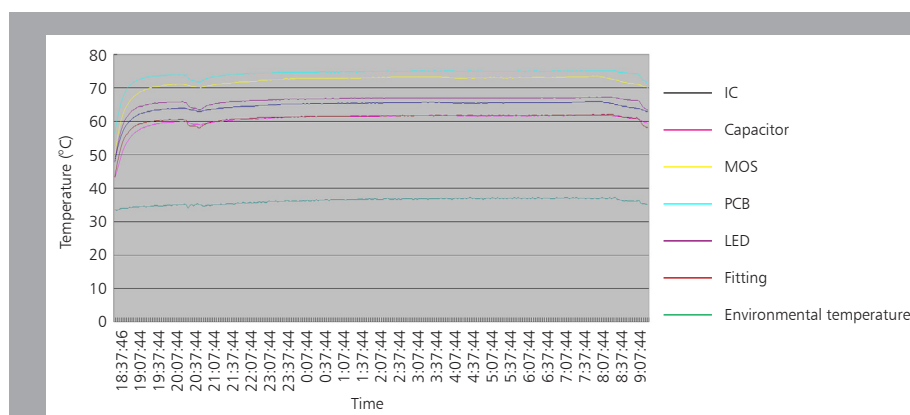

The driver lifespan is based on capacitor working temperature.

## Installation

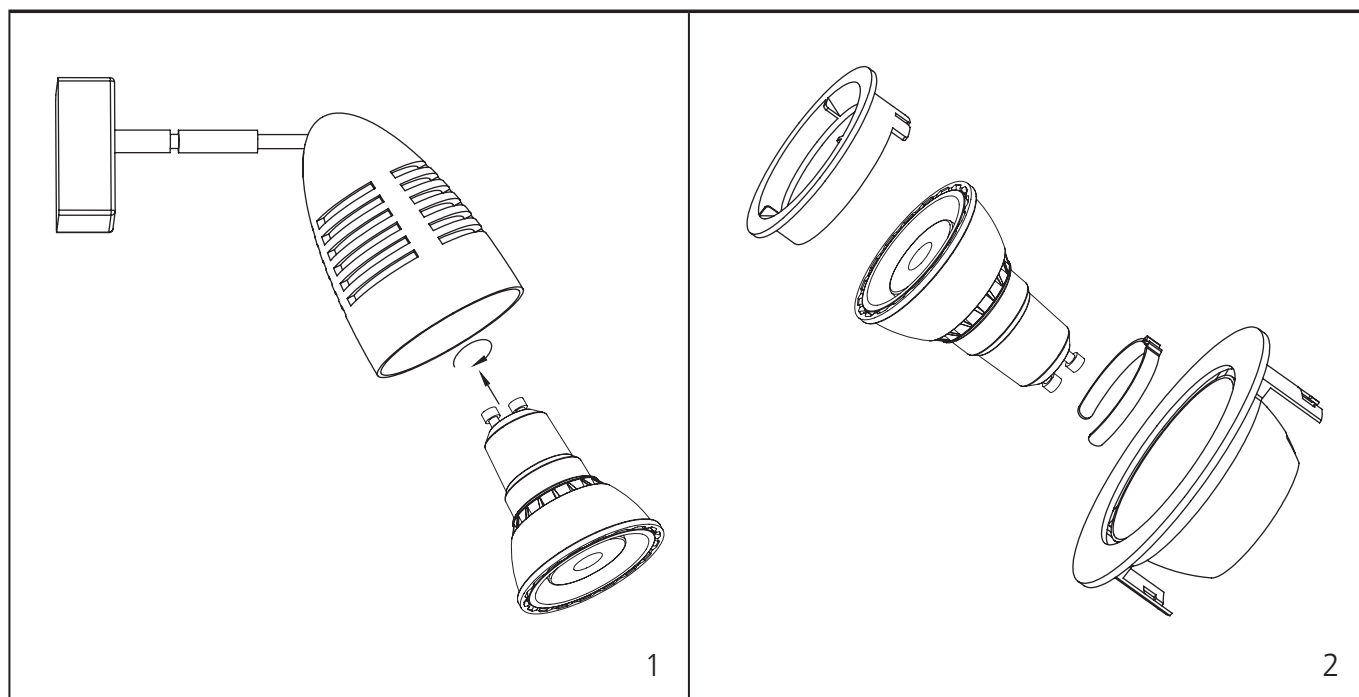

## Packaging Information

	SIZE(CM)	N.W/pc (KGS)	G.W.(KGS)	Q'TY(PCS)
Carton	29*29*30	0.055	7.0	100

	CTNS	Q'TY(PCS)	VOLUME(CBM)
20" standard container	1066	106600	28
40" standard container	2132	213200	56

