



UPSHINE<sup>®</sup>



Technical Application  
Guide for UP-SHINE  
LED Pendant Light

UP-PL3012-18W-W

# Introduction



Pendant led light acts as a decorative light in most applications. Elegant design creates soft lighting effect, various installation ways, such as suspended, surface mounted and recessed into ceiling. Perfect for hotels, restaurant, coffee shop etc. 300mm, 400mm, 500mm and 600mm diameter for wide choice.

- Up to 80% energy saving compared to standard CFL
- Long lifetime of 40,000 hours
- 120° wide beam angle
- CCT: 3000K 4000K  
5000K 5700K
- No UV/IR light
- Environment friendly, without Mercury or any other hazardous substances

## Application notes

- IP40 for indoor use only
- Professional electrician for installation only
- Switch off before installation
- Do not touch when in use
- Keep away from hot steam and corrosive gas

## Application Areas

It is widely used for various commercial and residential lighting applications, such as office, hotel, restaurant, home lighting etc.

## Certificates

**CE** **RoHS** **SAA**



# Product Information

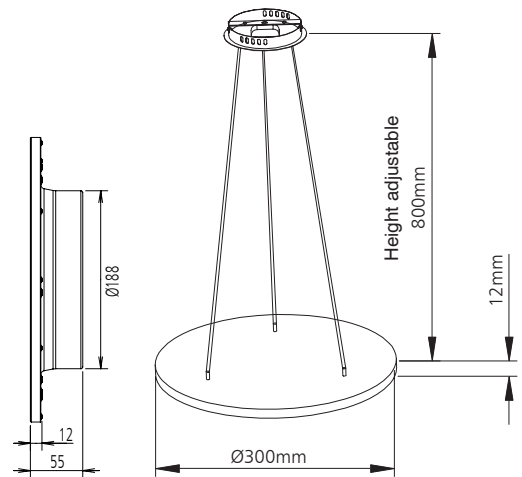
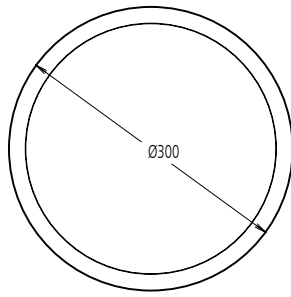

## Technical Specifications

Model	Voltage	Power	Power Factor	Lumen (±5%)	Beam angle	CCT	Lifespan	CRI	Dimmable
UP-PL3012-18W-W	AC230V	18W	≥0.9	1460	120°	3000K	40000h	≥80	No
UP-PL3012-18W-W	AC230V	18W	≥0.9	1475	120°	4000K	40000h	≥80	No
UP-PL3012-18W-W	AC230V	18W	≥0.9	1420	120°	5000K	40000h	≥80	No
UP-PL3012-18W-W	AC230V	18W	≥0.9	1560	120°	5700K	40000h	≥80	No
UP-PL3012-18W-W-D	AC230V	18W	≥0.9	1295	120°	3000K	40000h	≥80	Yes
UP-PL3012-18W-W-D	AC230V	18W	≥0.9	1330	120°	4000K	40000h	≥80	Yes
UP-PL3012-18W-W-D	AC230V	18W	≥0.9	1360	120°	5000K	40000h	≥80	Yes
UP-PL3012-18W-W-D	AC230V	18W	≥0.9	1450	120°	5700K	40000h	≥80	Yes

## Driver data Sheet

Driver data	DIM	Non-dim
Input rated Voltage	AC230V	AC230V
Frequency	50Hz	50Hz
Input Voltage	AC200-240V	AC200-240V
Efficiency	≥78%	≥78%
Total load Wattage	18W±1W	18W±1W
Power Factor	≥0.9	≥0.9
Rated input current	≤0.1A	≤0.2A
Full load output Voltage	DC35-40V	DC35-40V
Rated output current	380mA	420mA
Output current range	380mA±5%	420mA±5%
Power tolerance	±5%	±5%
Current output tolerance	±5%	±5%
Dimming range	8%-100%	—
Dimmer	Triac dimmers	—
Short circuit protection	PASS	PASS
Over voltage protection	PASS	PASS
Over temperature protection	PASS	PASS
THD	≤27%	≤10%
Withstand voltage	AC1500V	AC1500V

## Fixture Compatibility

Rated Wattage	Electrical Classification	Ingress Protection	Operating Temp	Operating Humidity	Storage Temp
18W	I	IP40	-20°C~45°C	0~90%	-20°C~65°C

# Spectral Distribution

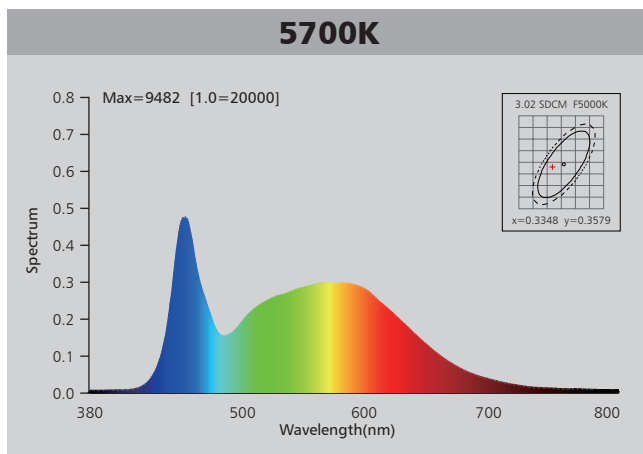
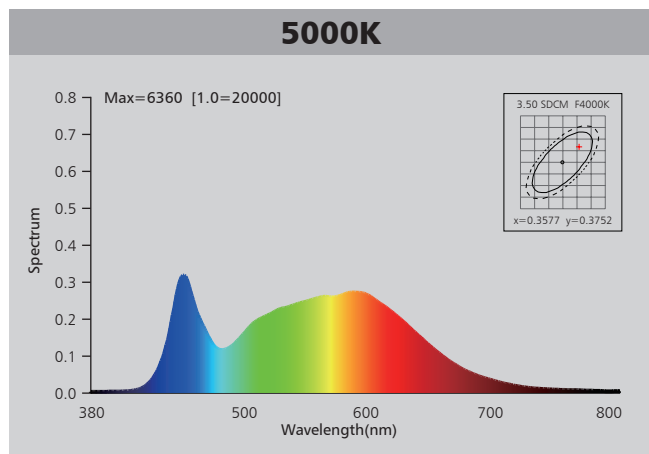
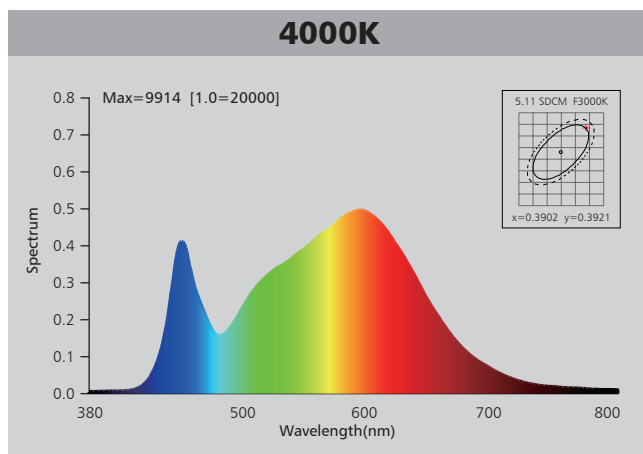
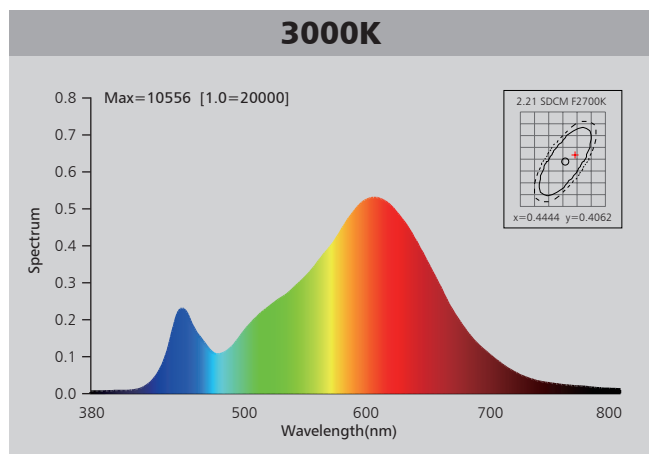

# Photometric Diagram

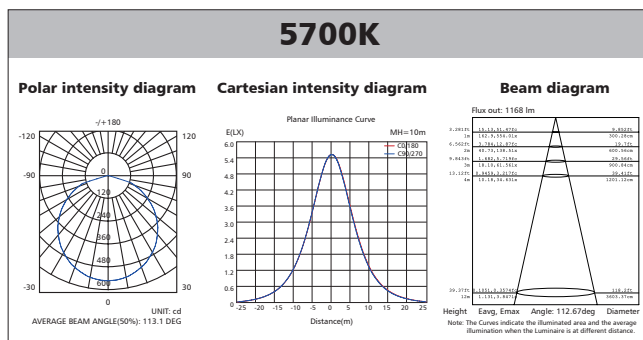
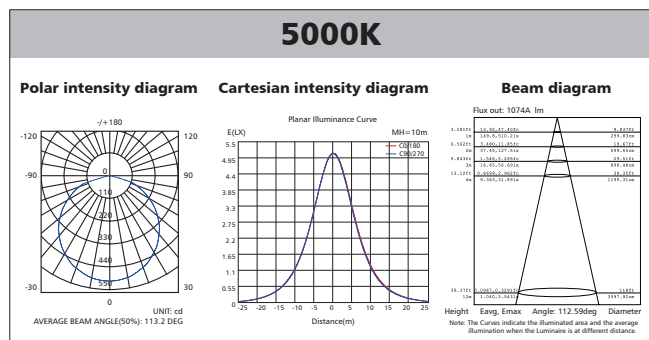
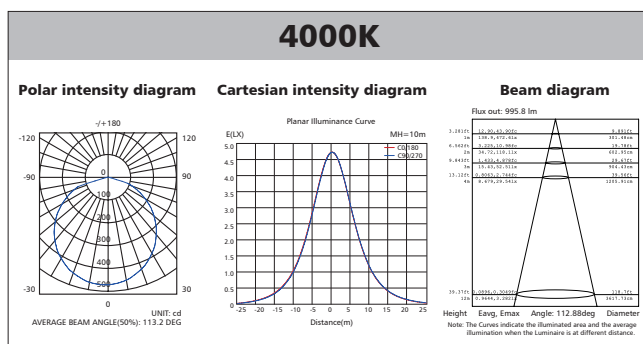
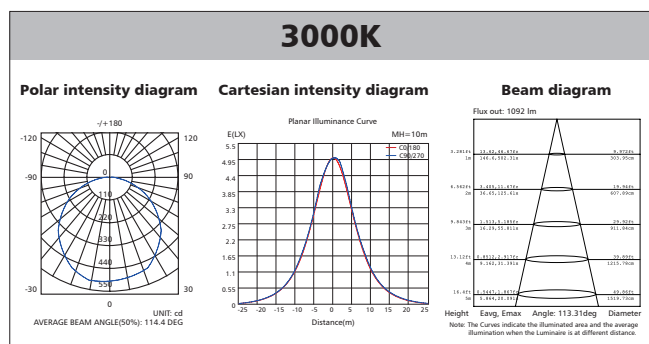

## Polar Diagram Comparison

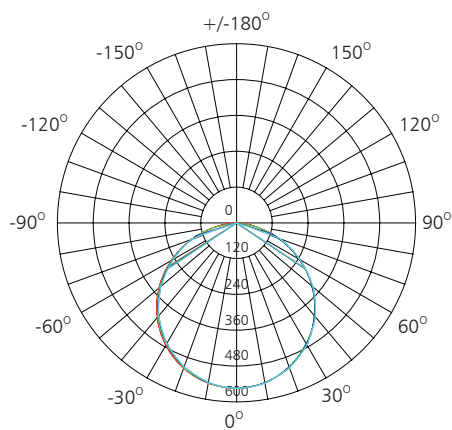

UNIT: cd

- C0/180, 113.8 deg
- C30/210, 113.3 deg
- C60/240, 112.9 deg
- C90/270, 112.7 deg

AVERAGE BEAM ANGLE (50%): 113.1DEG



## Driver lifetime & LED light decay rate

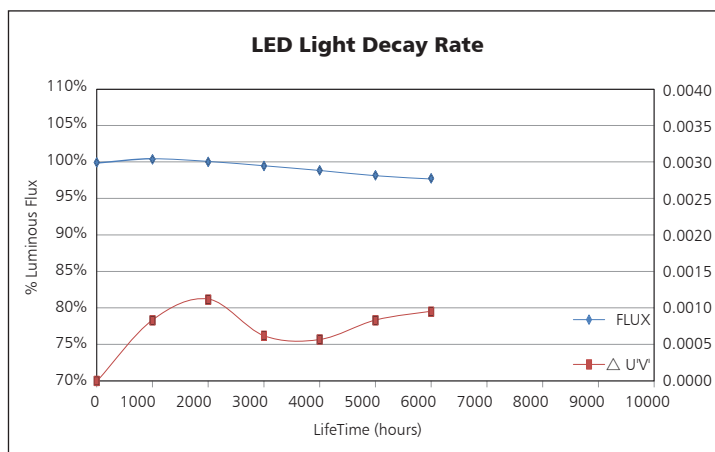
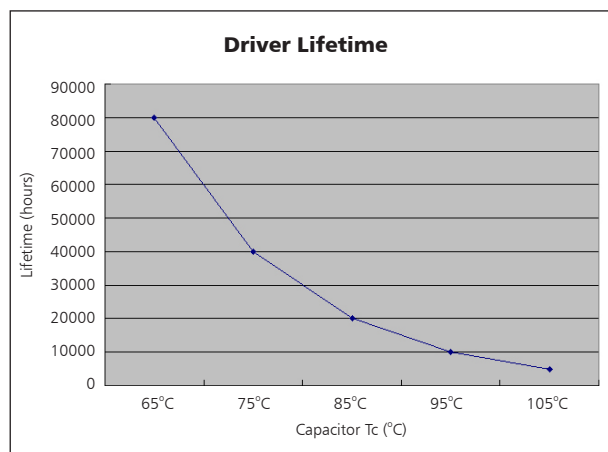

## Temperature

- The testing is operated at 25°C
- The lifetime of capacitor, minimum of 5,000 hours if operated at 105°C, will be doubled whenever the temperature drops 10°C
- The highest withstand temperature of IC, MOS could be 120°C
- The highest withstand temperature of LED junction temperature is 150°C

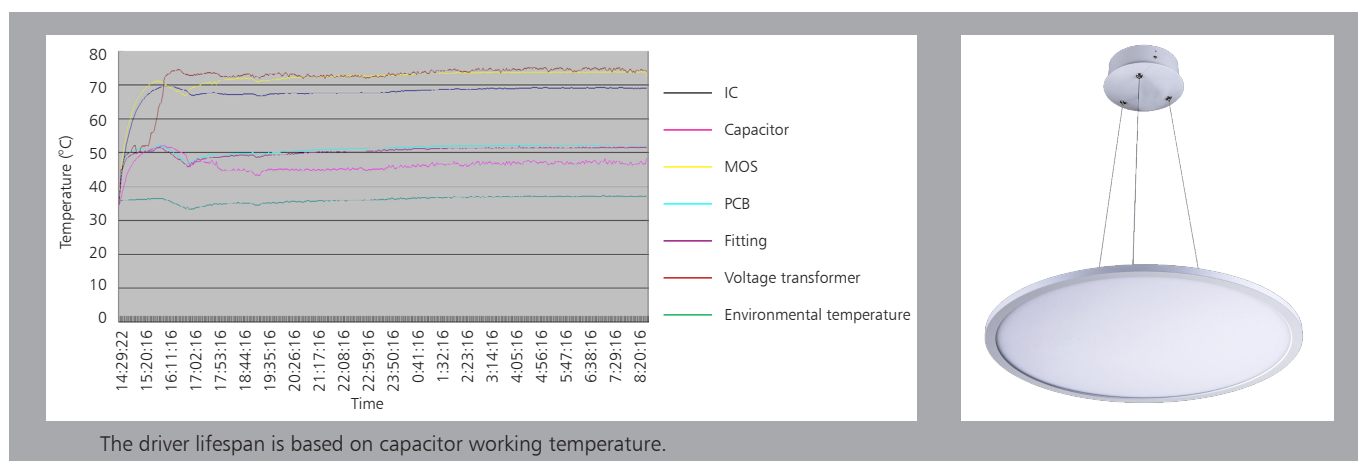

The driver lifespan is based on capacitor working temperature.

# Installation

## Suspended installation (Wooden ceiling):

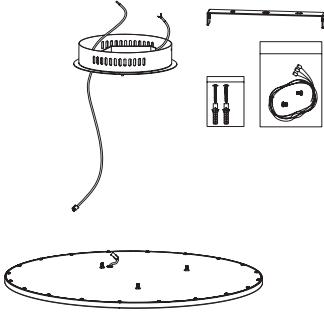
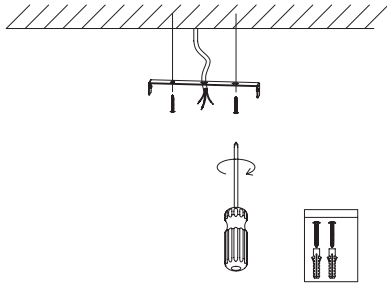
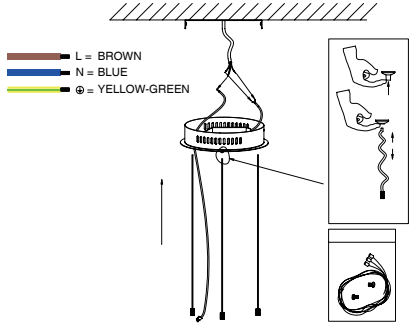
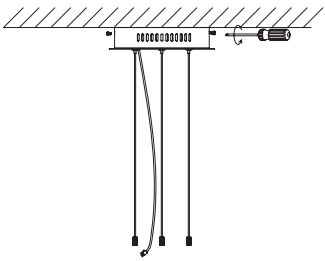
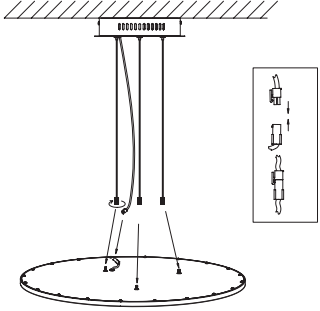
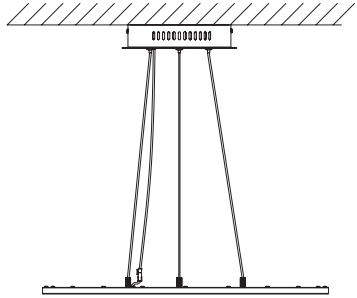
 <p>1. Unbox panel light and accessory pack.</p>	 <p>2. Switch off, fix bracket into ceiling with screw.</p>	 <p>3. Insert the hanging wire into wall mount bracket; connect L/N/E to mains supply.</p>
 <p>4. Fix the wall mount bracket into ceiling by screw.</p>	 <p>5. Hang panel to suspending rope and connect the DC connector</p>	 <p>6. Adjust the length of hanging wire to proper height, Restore the power and switch on.</p>

## Suspended installation (Concrete ceiling):

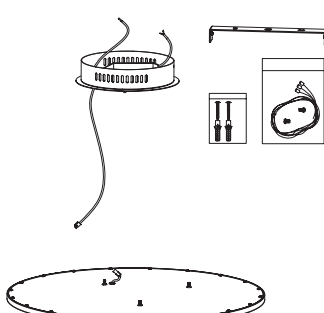
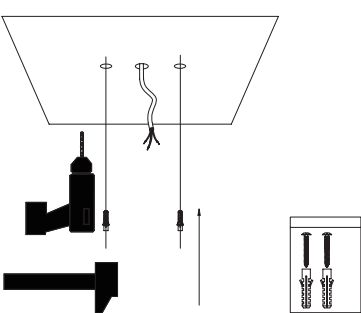
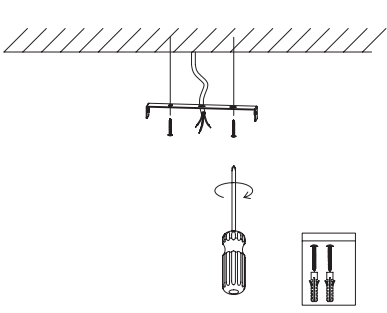
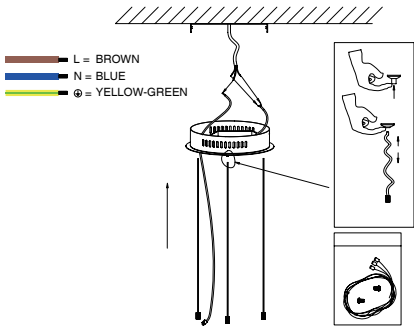
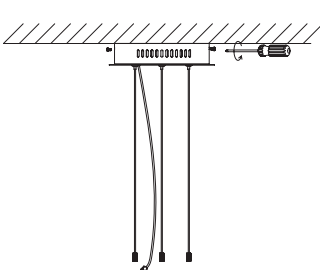
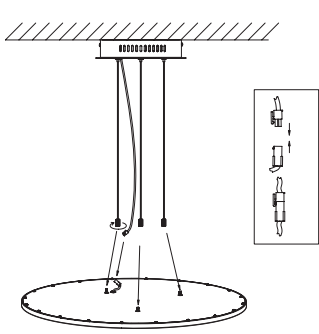
 <p>1. Unbox panel light and accessory pack</p>	 <p>2. Power off, Punch holes and knock the plastic anchor into ceiling</p>	 <p>3. Fix bracket into ceiling with screw.</p>
 <p>4. Insert the hanging wire into wall mount bracket; connect L/N/E to mains supply.</p>	 <p>5. Fix the wall mount bracket into ceiling by screw.</p>	 <p>6. Hang panel to suspending rope and connect the DC connector</p>

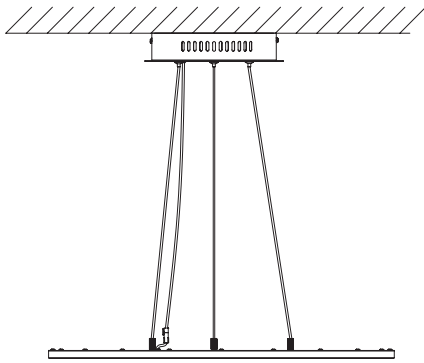

7. Adjust the length of hanging wire to proper height, Restore the power and switch on

## Recessed installation:

<p>1. Determine the mounting location, ceiling opening 200-220mm, mark the hole position of wall mount box and knock the plastic anchor into ceiling</p>	<p>2. Take out the wall mounted box from round panel by clockwise rotation. Disconnect the DC plug and fall-prevention rope.</p>	<p>3. Insert the wall mount box into the hole in the ceiling, fix it tightly by screws.</p>
<p>4. Connect the AC wires to the connection terminals in the mount box.</p> <p> <span style="color: brown;">—</span> L = BROWN  <span style="color: blue;">—</span> N = BLUE  <span style="color: yellowgreen;">—</span> ⊕ = YELLOW-GREEN         </p>	<p>5. Connect fall-prevention rope and the DC plug, then rotate anticlockwise the round panel into wall mount box until it is firmly attached.</p>	<p>6. Installation complete, switch on.</p>

## Surface mount installation:

<p>1. Determine the mounting location, mark the hole position of wall mount box and knock the plastic anchor into ceiling.</p>	<p>2. Take out the wall mounted box from round panel by clockwise rotation. Disconnect the DC plug and fall-prevention rope.</p>	<p>3. Fix the wall mount box on ceiling tightly by screws.</p>
--	--	--

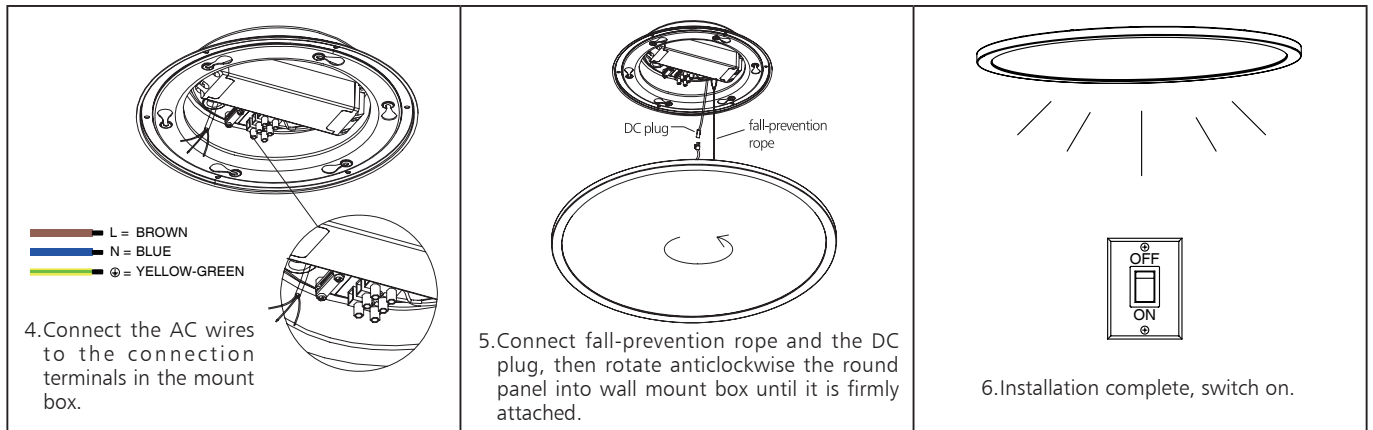

### Packaging Information(Suspended)

	SIZE(CM)	N.W/pc (KGS)	G.W.(KGS)	Q'TY(PCS)
Carton	35*26*55	2.2	11.5	5

	CTNS	Q'TY(PCS)	VOLUME(CBM)
20" standard container	548	2740	28
40" standard container	1096	5480	56

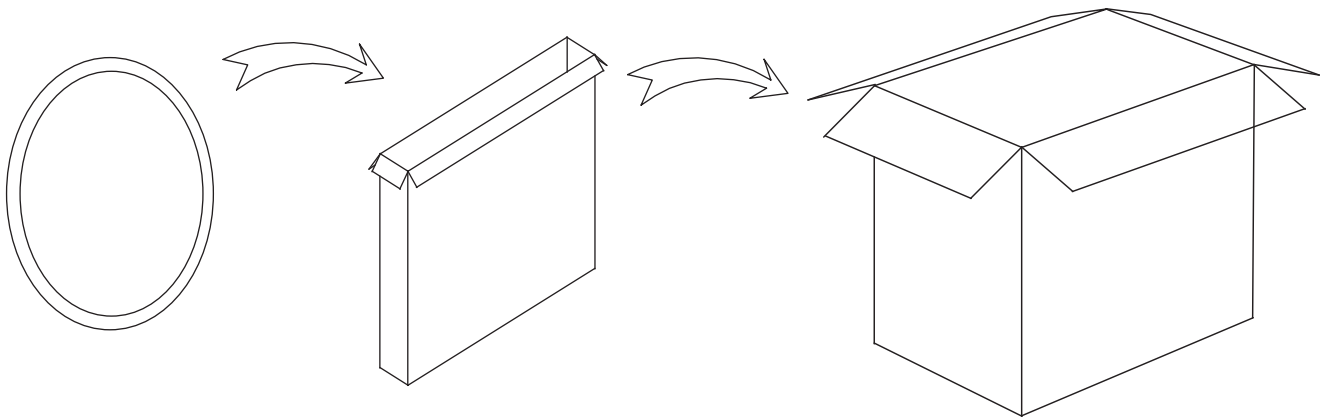

### (Surface mount & recessed)

	SIZE(CM)	N.W/pc (KGS)	G.W.(KGS)	Q'TY(PCS)
Carton	36*37.5*36	2.5	13	5

	CTNS	Q'TY(PCS)	VOLUME(CBM)
20" standard container	576	2880	28
40" standard container	1152	5760	56

