



Up-shine[®] Lighting



Technical Application
Guide for UP-SHINE
LED Panel Light

UP-PL6060-27W-E

Introduction

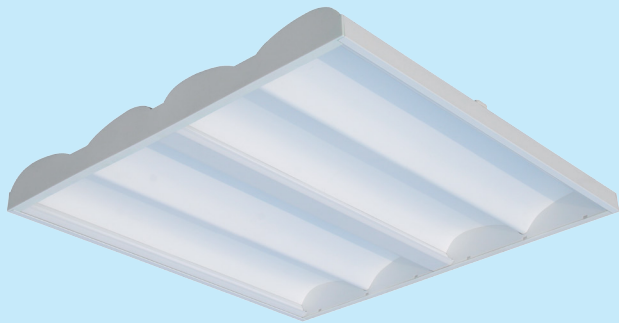

Edge Lit LED Panel luminare combines high reflection material with unique curved design to achieve unparalleled Optical effect. Lower UGR, greatly reduced discomforts caused to our eyes. It is a panel without LGP, another way of cost saving. The reflector is made of high reflectivity PC material with 94-V0 fire rating, it creates high lumen output, light efficiency up to 95lm/W. Clear or prismatic diffuser for your choice. Dimmable option: triac dim or 0-10V dim. Compared with regular panel, the new design is lighter to carry, easier to install and maintain.

- Low cost with high performance
- Low UGR <19
- 94-V0 fire rating PC
- Clear or prismatic diffuser
- High light efficiency of 95LM/W
- Wide range of control gear for option

Application notes

- IP20 for indoor use only
- Professional electrician for installation only
- Switch off before installation
- Do not touch when in use
- Keep away from hot steam and corrosive gas

Application Areas

Office & school lighting: office, meeting room, class room etc.

Commercial lighting: shopping mall, super market, retailer shops etc.

Other situations: hospital, laboratory, dust-free workshop etc.

Certificates

CE RoHS



Product Information

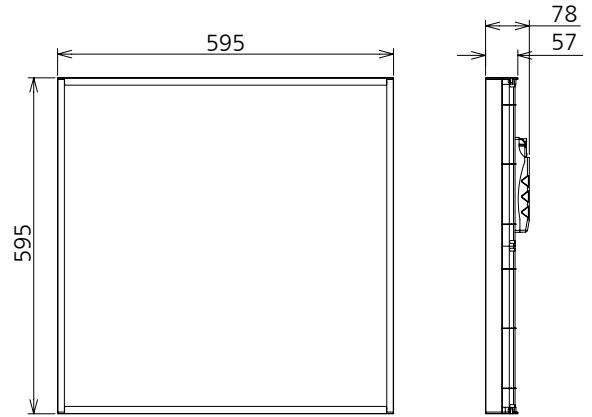

Technical Specifications

Model	Voltage	Power	Power Factor	Lumen (±5%)	Beam angle	CCT	Lifespan	CRI	Dimmable	Dimension
UP-PL6060-27W-E	AC230V	27W	≥0.9	2550	120°	3000K	40000h	≥80	No	595*595*78mm
UP-PL6060-27W-E	AC230V	27W	≥0.9	2700	120°	4000K	40000h	≥80	No	595*595*78mm
UP-PL6060-27W-E	AC230V	27W	≥0.9	2750	120°	5000K	40000h	≥80	No	595*595*78mm
UP-PL6060-27W-E	AC230V	27W	≥0.9	2600	120°	5700K	40000h	≥80	No	595*595*78mm
UP-PL6060-27W-E-D	AC230V	27W	≥0.9	2500	120°	3000K	40000h	≥80	Yes	595*595*78mm
UP-PL6060-27W-E-D	AC230V	27W	≥0.9	2620	120°	4000K	40000h	≥80	Yes	595*595*78mm
UP-PL6060-27W-E-D	AC230V	27W	≥0.9	2700	120°	5000K	40000h	≥80	Yes	595*595*78mm
UP-PL6060-27W-E-D	AC230V	27W	≥0.9	2600	120°	5700K	40000h	≥80	Yes	595*595*78mm

Driver data Sheet

Driver data	DIM	Non-dim
Input rated Voltage	AC230V	AC230V
Frequency	50Hz	50Hz
Input Voltage	AC200-240V	AC200-240V
Efficiency	≥85%	≥88%
Total load Wattage	27W±5%	27W±5%
Power Factor	≥0.9	≥0.9
Rated input current	≤0.16A	≤0.16A
Full load output Voltage	DC35-38V	DC35-38V
Rated output current	650mA	680mA
Output current range	650mA±5%	680mA±5%
Power tolerance	±5%	±5%
Current output tolerance	±5%	±5%
Dimming range	8%-100%	—
Dimmer	Triac dimmers	—
Short circuit protection	PASS	PASS
Over voltage protection	PASS	PASS
Over temperature protection	PASS	PASS
Withstand voltage	AC3750V	AC3750V

Fixture Compatibility

Rated Wattage	Electrical Classification	Ingress Protection	Operating Temp	Operating Humidity	Storage Temp
27W	II	IP20	-20°C~45°C	0~90%	-20°C~65°C

Spectral Distribution

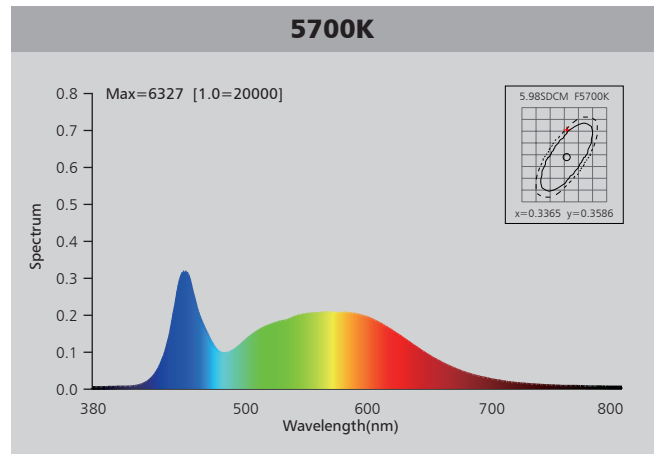
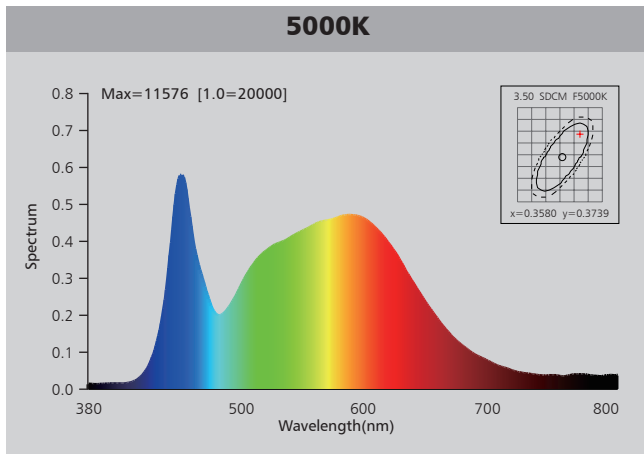
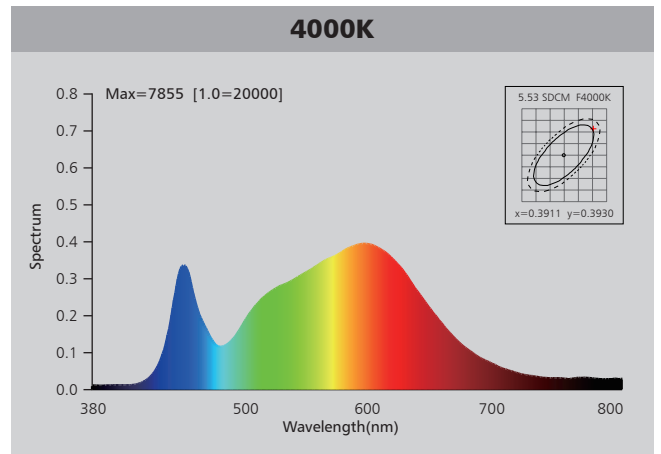
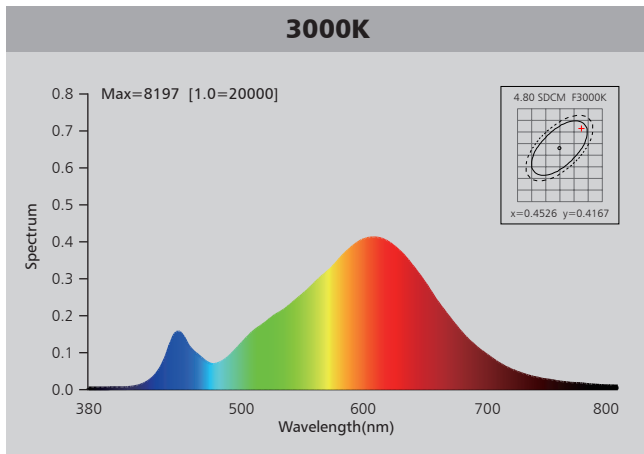

Photometric Diagram

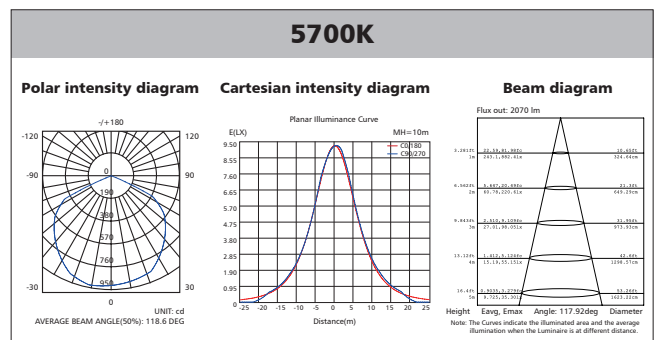
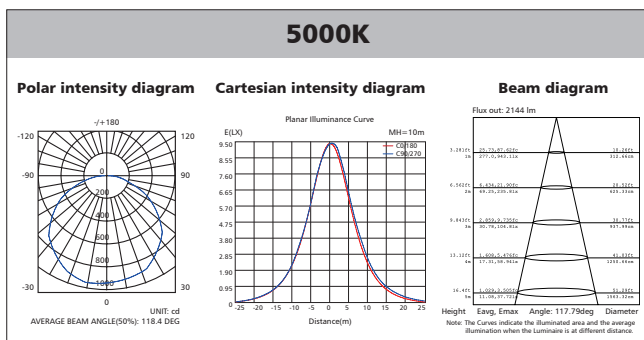
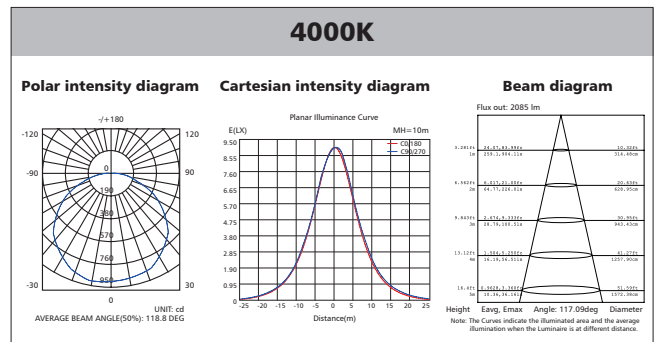
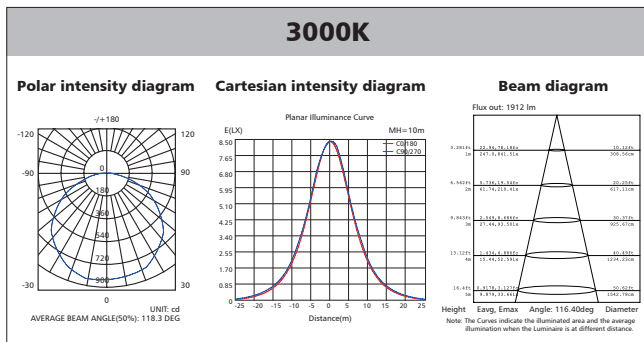

Polar Diagram Comparison

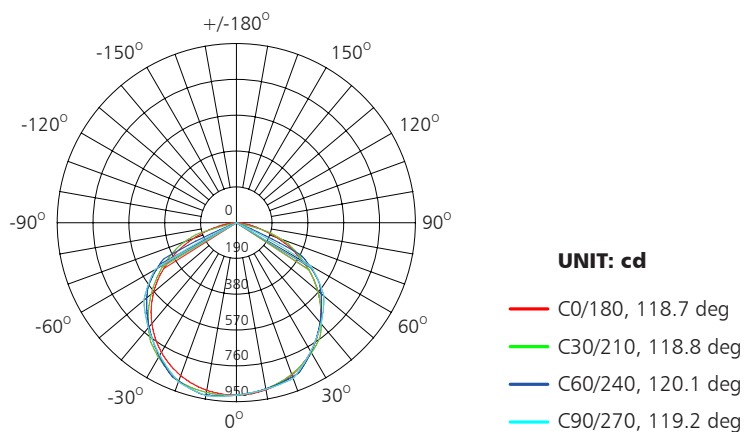

AVERAGE BEAM ANGLE (50%): 118.6DEG



Driver lifetime & LED light decay rate

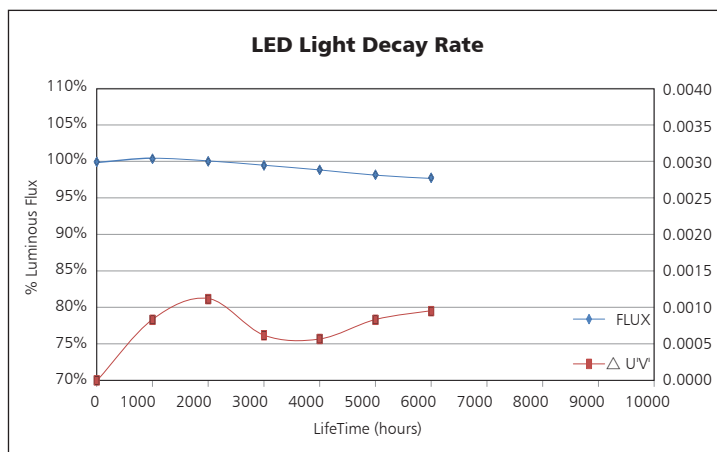
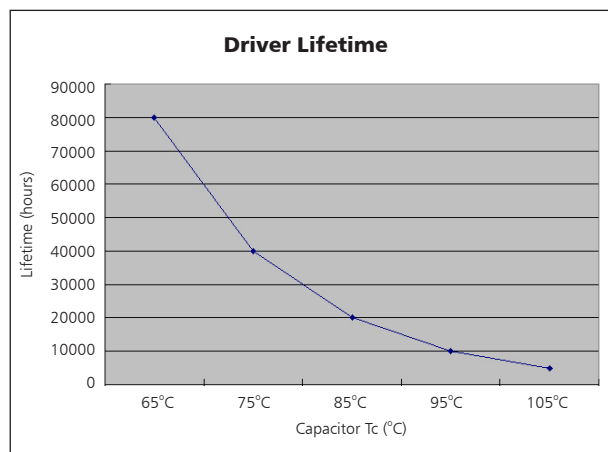

Temperature

- The testing is operated at 25°C
- The lifetime of capacitor, minimum of 5,000 hours if operated at 105°C, will be doubled whenever the temperature drops 10°C
- The highest withstand temperature of IC, MOS could be 120°C
- The highest withstand temperature of LED junction temperature is 150°C

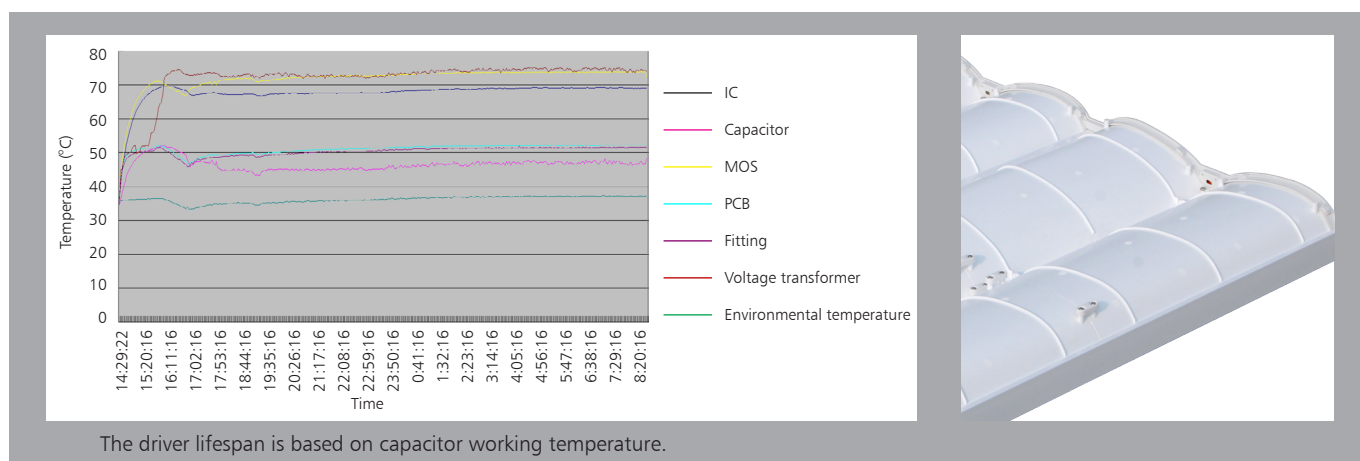

Installation

1. Recessed into ceiling

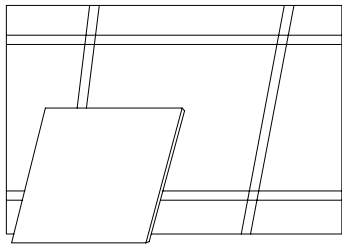
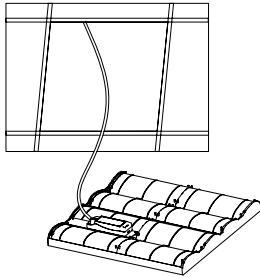
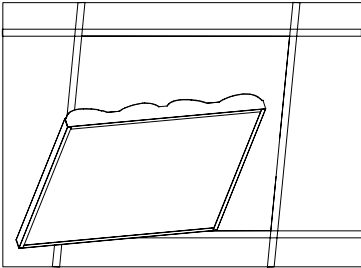
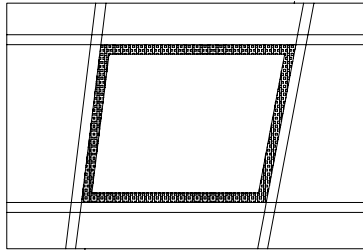
 <p>1. Remove ceiling plaster slab</p>	 <p>2. Connect power supply</p>
 <p>3. Fix the panel light into right place</p>	 <p>4. Stabilize the panel</p>

2. Suspending

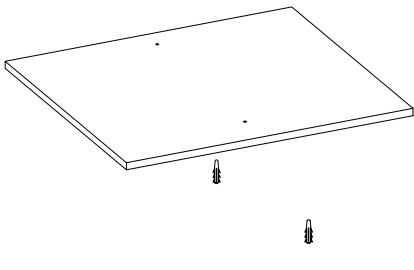
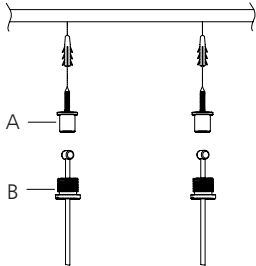
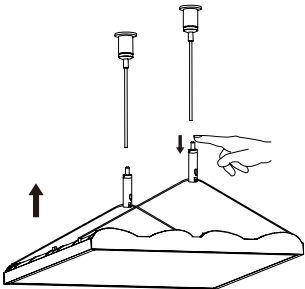
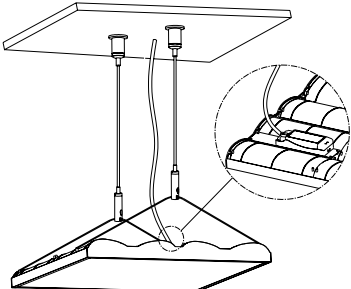
 <p>1. Knock the plastic anchor into concrete ceiling.</p>	 <p>2. Fix part A with tapping screw to ceiling, Wirerope goes through part B, and then screw B into A.</p>
 <p>3. Lock the wirerope into two locking devices, the one on the ceiling and another at the back of panel light.</p>	 <p>4. Adjust the length of hanging wire, make sure the panel is level with the ground. Connect power supply and restore power. Check for correct operation.</p>

Packaging Information

	SIZE(CM)	N.W/pc (KGS)	G.W.(KGS)	Q'TY(PCS)
Carton	65*42.5*65	3.6	15.5	4

	CTNS	Q'TY(PCS)	VOLUME(CBM)
20" standard container	155	620	28
40" standard container	310	1240	56

