



UPSHINE®



Technical Application
Guide for UP SHINE
LED Panel Light

UP-PL6060-40W-AN

Introduction



Up-shine LED panel adopts high lumen SMD LED with CRI >80. Top branded driver comes with triac dim, 0-10V dim and DALI dim, it has perfect dimming range and shares great compatibility with worldwide famous brand dimmers.

The ultra slim profile fits seamlessly into any work place. It is available in various installation ways: embedded into ceiling, suspended with hanging wires, surface mounted in a concrete ceiling by using surface mounting frame.

- Up to 80% energy saving compared to standard CFL
- Long lifetime of 40,000 hours
- Triac dim, 0-10V dim, DALI dim
- 120° wide beam angle
- CCT: 3000K 4000K 5000K 5700K
- No UV/IR light
- Environment friendly, without Mercury or any other hazardous substances

Application notes

- IP40 for indoor use only
- Professional electrician for installation only
- Switch off before installation
- Do not touch when in use
- Keep away from hot steam and corrosive gas

Application Areas

Office & school lighting: office room, meeting room, class room etc.

Commercial lighting: shopping mall, super market, retailer shops etc.

Other situations: hospital, laboratory, dust-free workshop etc.

Certificates

CE RoHS SAA



Product Information

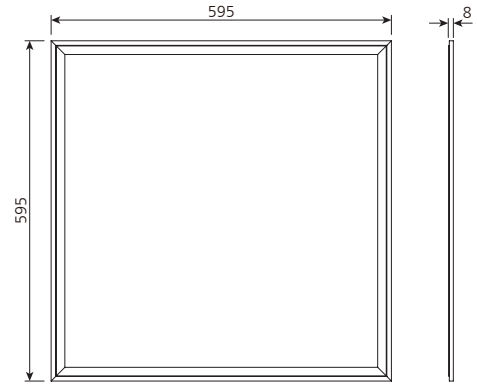

Technical Specifications

| Model | Voltage | Power | Power Factor | Lumen (±5%) | CCT | Beam angle | Lifespan | CRI | Dimmable | Dimension |
|--------------------|---------|-------|--------------|-------------|-------|------------|----------|-----|----------|-------------|
| UP-PL6060-40W-AN | AC230V | 40W | ≥0.9 | 3650 | 3000K | 120° | 40000h | ≥80 | No | 595*595*8mm |
| | | | | 3850 | 4000K | | | | | |
| | | | | 3900 | 5000K | | | | | |
| | | | | 3950 | 5700K | | | | | |
| UP-PL6060-40W-AN-D | AC230V | 40W | ≥0.9 | 3600 | 3000K | 120° | 40000h | ≥80 | Yes | 595*595*8mm |
| | | | | 3800 | 4000K | | | | | |
| | | | | 3850 | 5000K | | | | | |
| | | | | 3900 | 5700K | | | | | |

Driver data Sheet

| Driver data | DIM | Non-dim |
|-----------------------------|---------------|------------|
| Input rated Voltage | AC230V | AC230V |
| Frequency | 50Hz | 50Hz |
| Input Voltage | AC200-240V | AC200-240V |
| Efficiency | ≥83% | ≥86% |
| Total load Wattage | 40W±5% | 40W±5% |
| Power Factor | ≥0.9 | ≥0.9 |
| Rated input current | ≤0.23A | ≤0.23A |
| Full load output Voltage | DC35-38V | DC35-38V |
| Rated output current | 950mA | 950mA |
| Output current range | 950mA±5% | 950mA±5% |
| Power tolerance | ±5% | ±5% |
| Current output tolerance | ±5% | ±5% |
| Dimming range | 8%-100% | — |
| Dimmer | Triac dimmers | — |
| Short circuit protection | PASS | PASS |
| Over voltage protection | PASS | PASS |
| Over temperature protection | PASS | PASS |
| Withstand voltage | AC3750V | AC3750V |

Fixture Compatibility

| Rated Wattage | Electrical Classification | Ingress Protection | Operating Temp | Operating Humidity | Storage Temp |
|---------------|---------------------------|--------------------|----------------|--------------------|--------------|
| 40W | II | IP40 | -20°C~45°C | 0~90% | -20°C~65°C |

Spectral Distribution

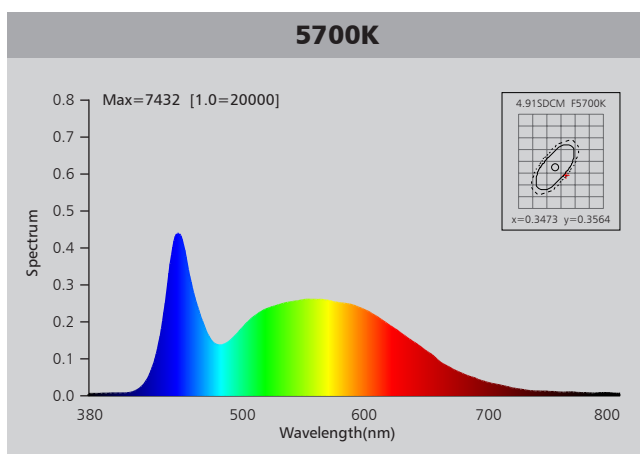
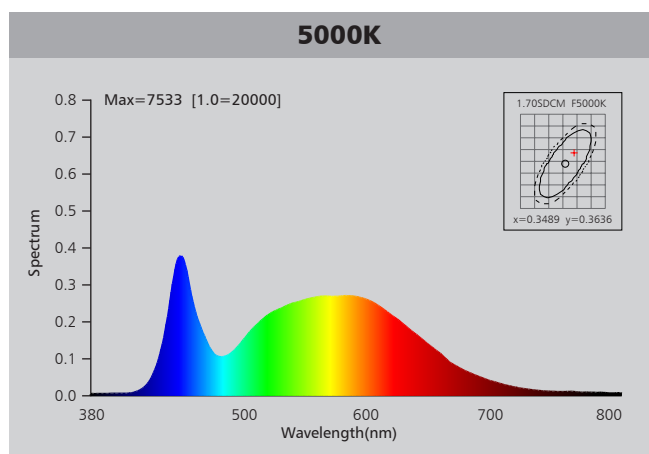
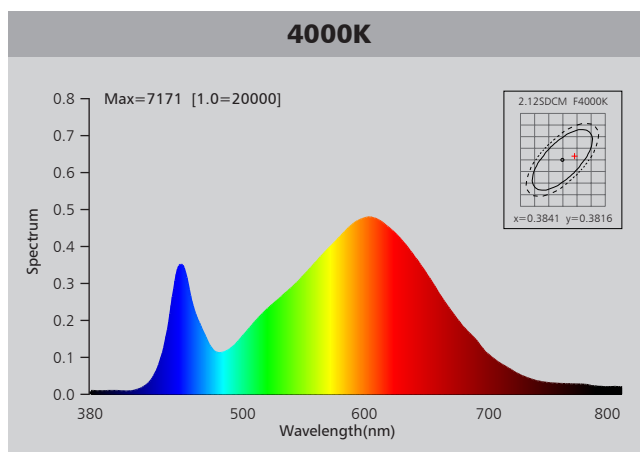
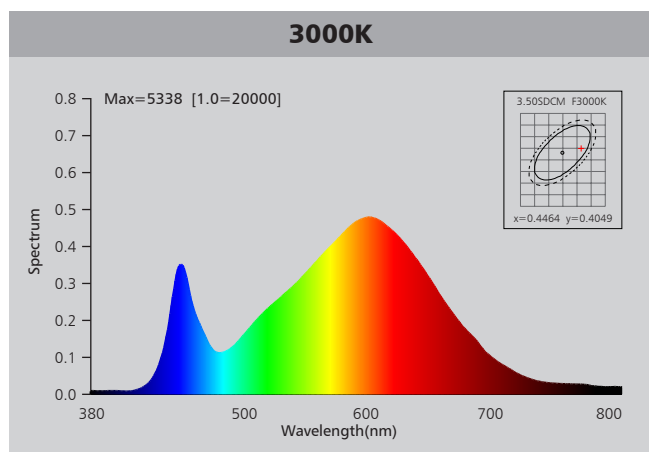

Photometric Diagram

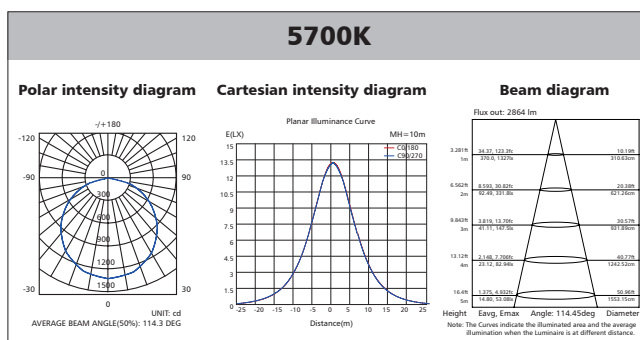
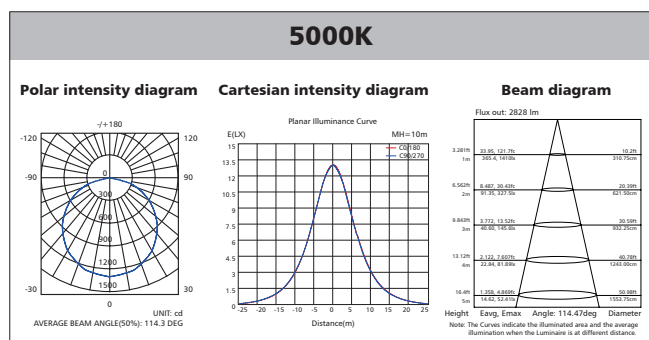
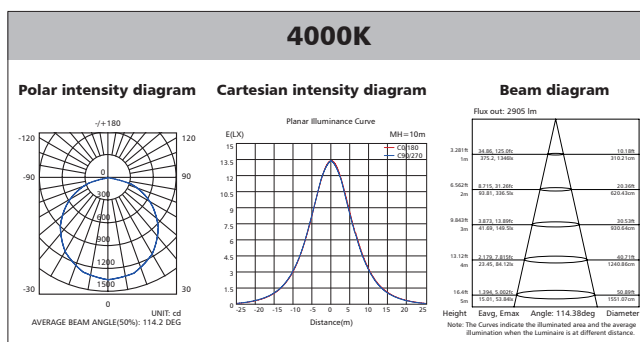
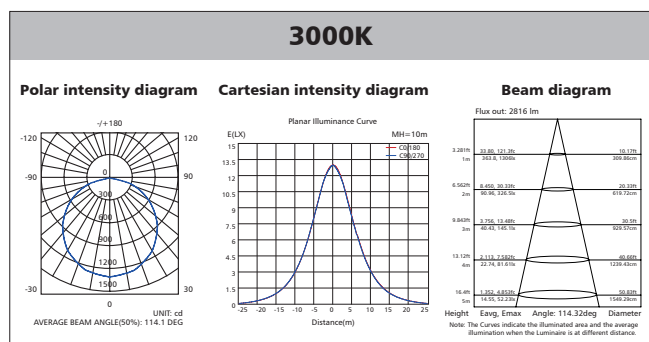

Polar Diagram Comparison

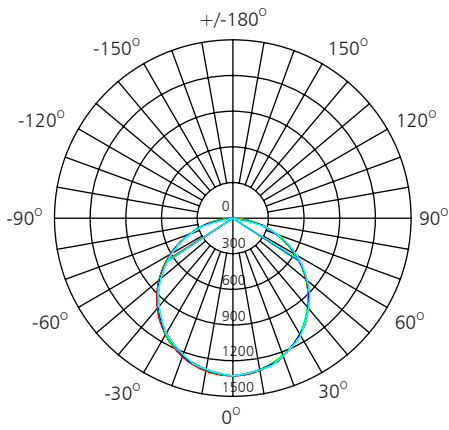

UNIT: cd

- C0/180, 114.5 deg
- C30/210, 114.0 deg
- C60/240, 114.1 deg
- C90/270, 114.4 deg

AVERAGE BEAM ANGLE (50%): 114.2DEG

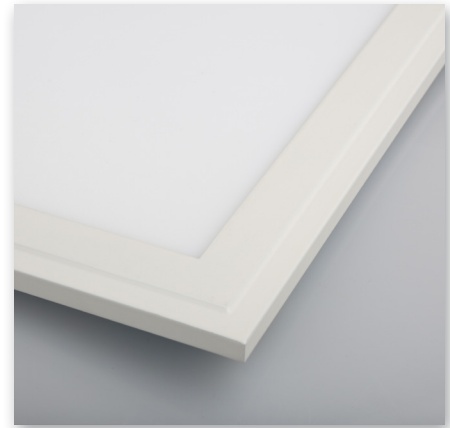

Driver lifetime & LED light decay rate

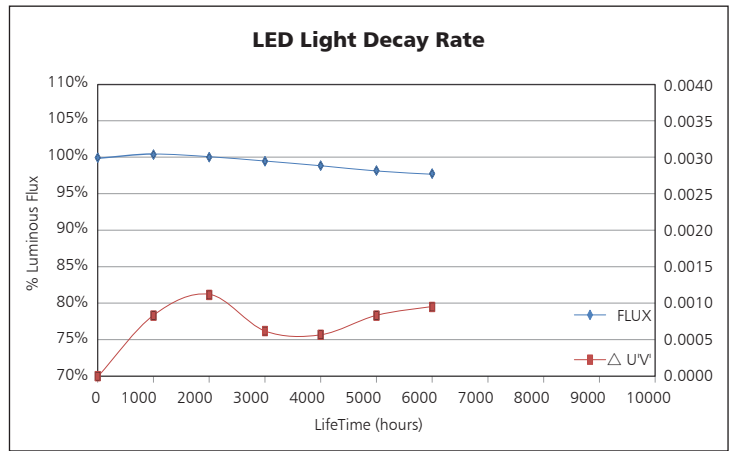
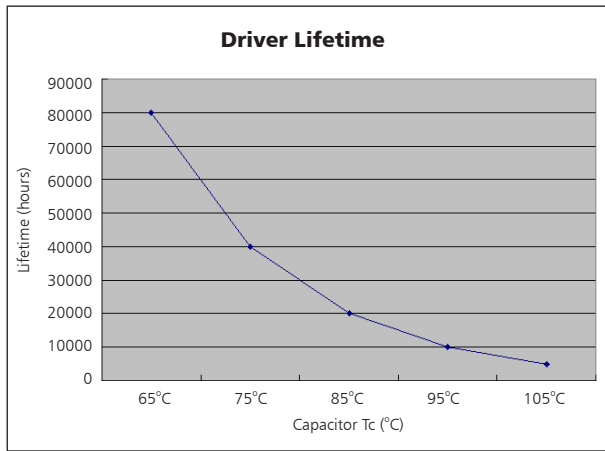

Temperature

- The testing is operated at 25°C
- The lifetime of capacitor, minimum of 5,000 hours if operated at 105°C, will be doubled whenever the temperature drops 10°C
- The highest withstand temperature of IC, MOS could be 120°C
- The highest withstand temperature of LED junction temperature is 150°C

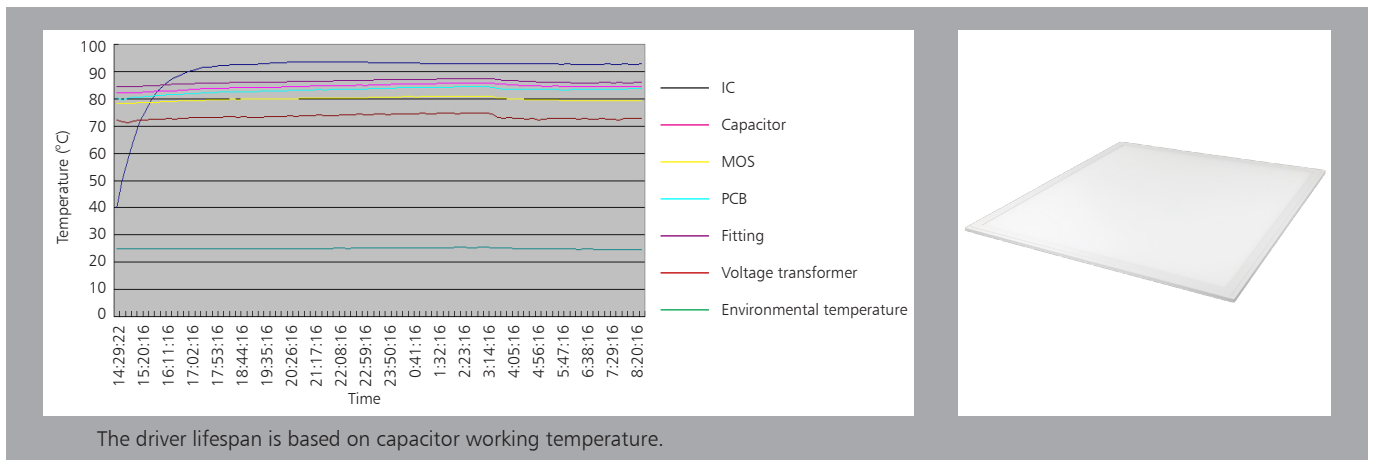

The driver lifespan is based on capacitor working temperature.

Installation

1. Recessed into ceiling

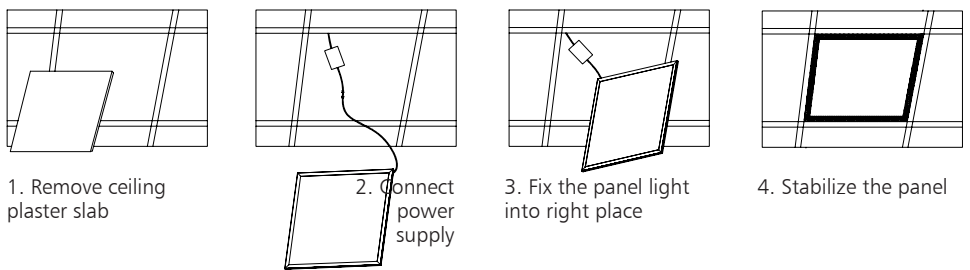

1. Remove ceiling plaster slab
2. Connect power supply
3. Fix the panel light into right place
4. Stabilize the panel

2. Suspending

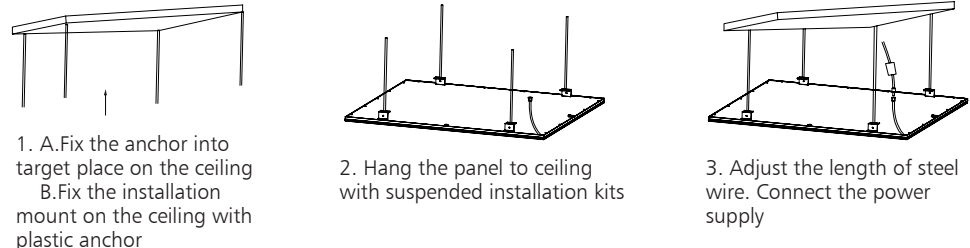

1. A. Fix the anchor into target place on the ceiling
B. Fix the installation mount on the ceiling with plastic anchor
2. Hang the panel to ceiling with suspended installation kits
3. Adjust the length of steel wire. Connect the power supply

3. Surface mounted

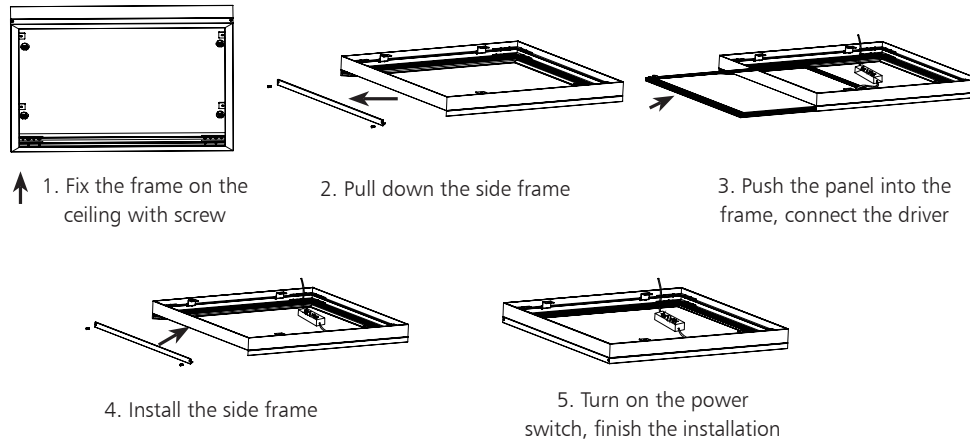

1. Fix the frame on the ceiling with screw
2. Pull down the side frame
3. Push the panel into the frame, connect the driver
4. Install the side frame
5. Turn on the power switch, finish the installation

Packaging Information

| | SIZE(CM) | N.W/pc (KGS) | G.W.(KGS) | Q'TY(PCS) |
|--------|------------|--------------|-----------|-----------|
| Carton | 66*22.5*71 | 2.5 | 18.5 | 5 |

| | CTNS | Q'TY(PCS) | VOLUME(CBM) |
|------------------------|------|-----------|-------------|
| 20" standard container | 260 | 1300 | 28 |
| 40" standard container | 520 | 2600 | 56 |

