

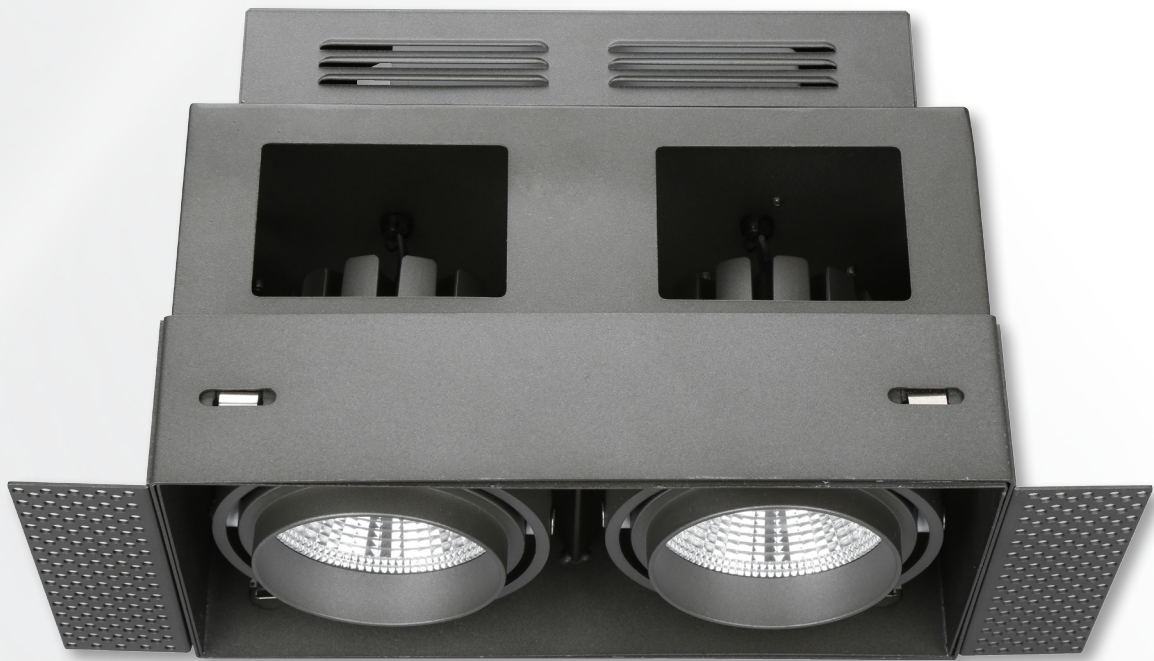

Up-shine® Lighting



Technical Application Guide for UP-SHINE LED Grille Downlight

UP-RD03-24W

Introduction



Up-shine rectangular LED grille downlight is unique designed with COB high power LED chip.

High efficient reflector with COB LED provides high lumen output and wide beam angle. Single head, double head and triple head provided for wide choice. Adjustable lighting direction offers various lighting orientation.

- Up to 70% energy saving compared to standard CFL
- Long lifetime of 40,000 hours
- 24° wide beam angle
- L228*W116mm cutout
- CCT: 2700K 3000K
4000K 5000K
- Adjustable and rotary
- No UV/IR light
- Environment friendly, without Mercury or any other hazardous substances

Application notes

- IP20 for indoor use only
- Professional electrician for installation only
- Switch off before installation
- Do not touch when in use
- Keep away from hot steam and corrosive gas

Application Areas

It is designed for general lighting applications in office, supermarket, shop, school, hotel, etc. It is also widely used for public areas, such as stairway, lobby, reception, corridors etc.

Certificate

CE RoHS



Product Information

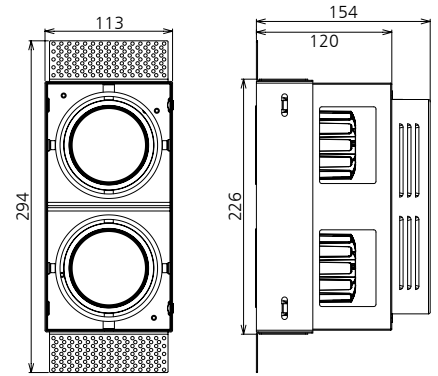

Technical Specifications

Model	Voltage	Power	Power Factor	Lumen (±5%)	Beam angle	CCT	Lifespan	CRI	Dimension
UP-RD03-24W	AC230V	24W	≥0.9	1600	24°	2700K	40000h	≥80	L294*W113*H154mm cutout L228*W116mm
UP-RD03-24W	AC230V	24W	≥0.9	1700	24°	3000K	40000h	≥80	L294*W113*H154mm cutout L228*W116mm
UP-RD03-24W	AC230V	24W	≥0.9	2040	24°	4000K	40000h	≥80	L294*W113*H154mm cutout L228*W116mm
UP-RD03-24W	AC230V	24W	≥0.9	1960	24°	5000K	40000h	≥80	L294*W113*H154mm cutout L228*W116mm

Driver data Sheet

Driver data	Non dim
Input rated Voltage	AC230V
Frequency	50Hz
Input Voltage	AC200-240V
Efficiency	≥85%
Total load Wattage	24W±5%
Power Factor	≥0.9
Rated input current	≤0.14A
Full load output Voltage	DC27-40V
Rated output current	550mA
Output current range	550mA±5%
Power tolerance	±5%
Current output tolerance	±5%
Dimming range	—
Dimmer	—
Short circuit protection	PASS
Over voltage protection	PASS
Over temperature protection	PASS
THD	≤20%
Withstand voltage	AC1500V

Fixture Compatibility

Rated Wattage	Electrical Classification	Ingress Protection	Operating Temp	Operating Humidity	Storage Temp
24W	I	IP20	-20°C~45°C	0~90%	-20°C~65°C

Spectral Distribution

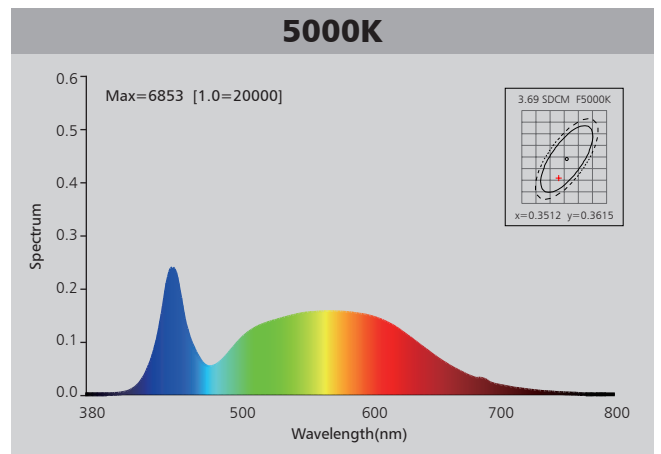
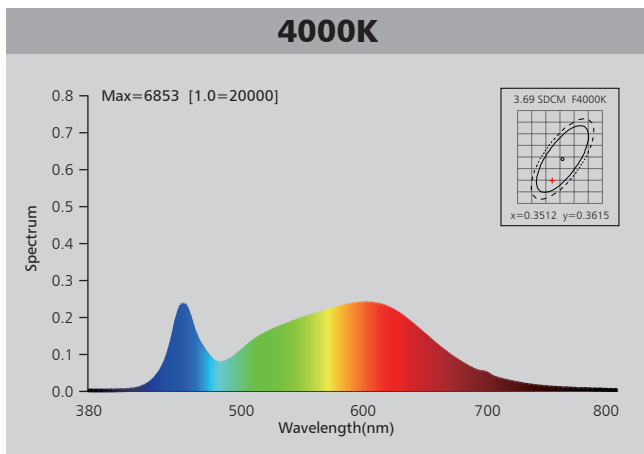
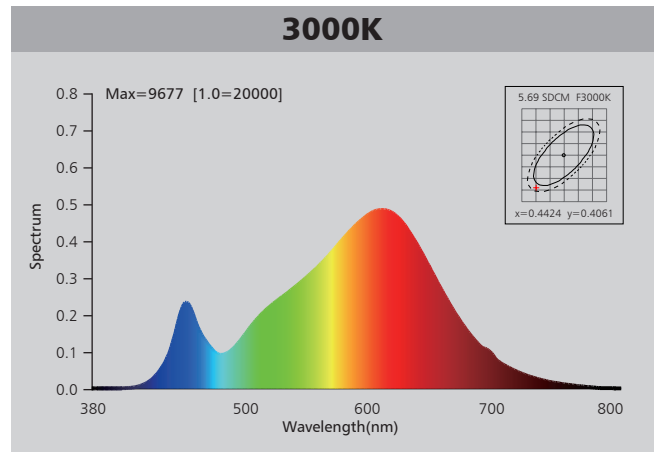
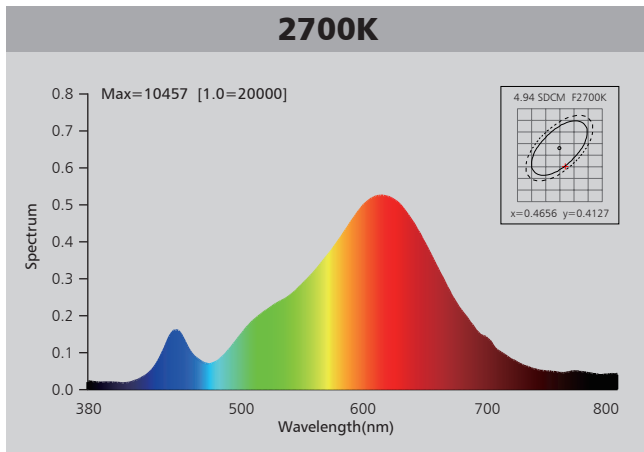

Photometric Diagram

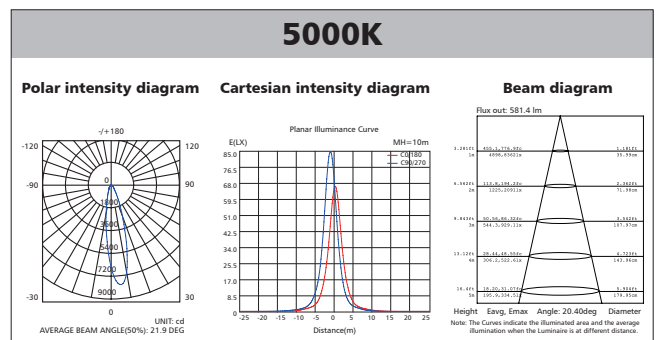
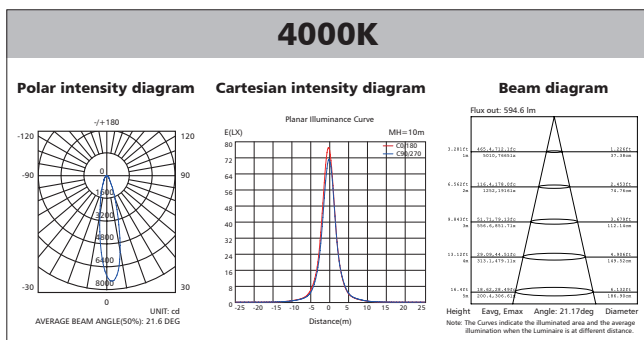
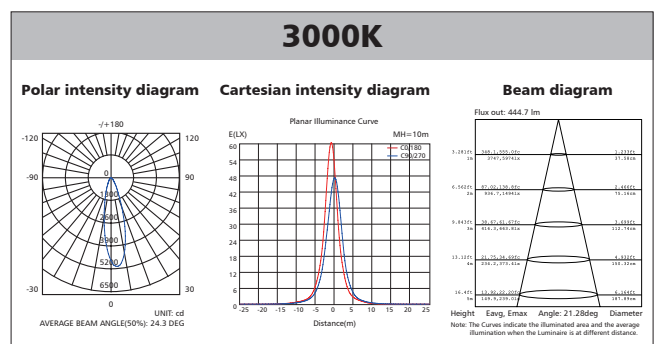
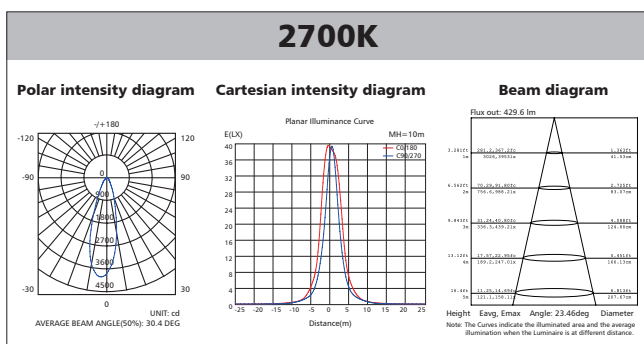

Polar Diagram Comparison

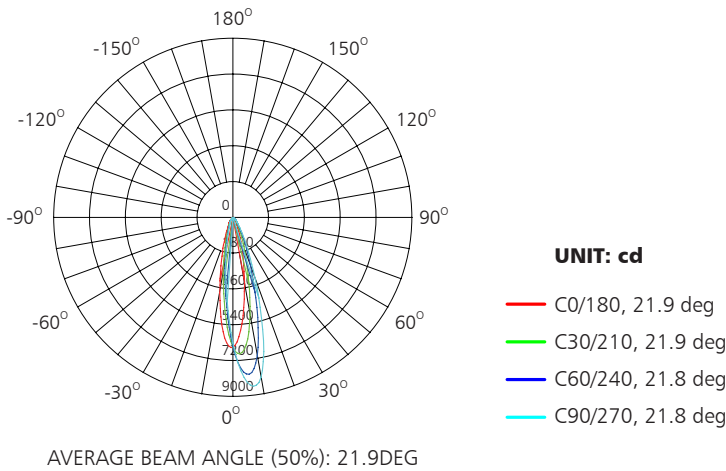

Driver lifetime & LED light decay rate

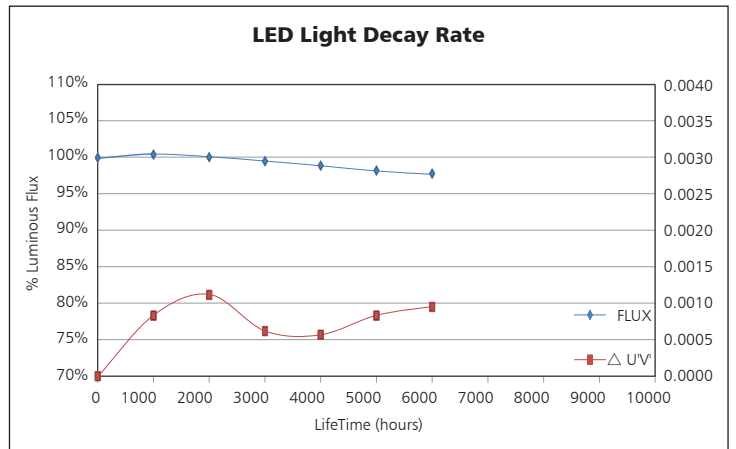
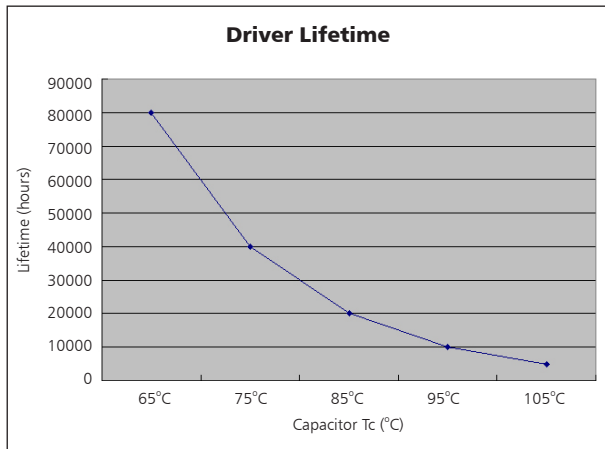

Temperature

- The testing is operated at 25°C
- The lifetime of capacitor, minimum of 5,000 hours if operated at 105°C, will be doubled whenever the temperature drops 10°C
- The highest withstand temperature of IC, MOS could be 120°C
- The highest withstand temperature of LED junction temperature is 150°C

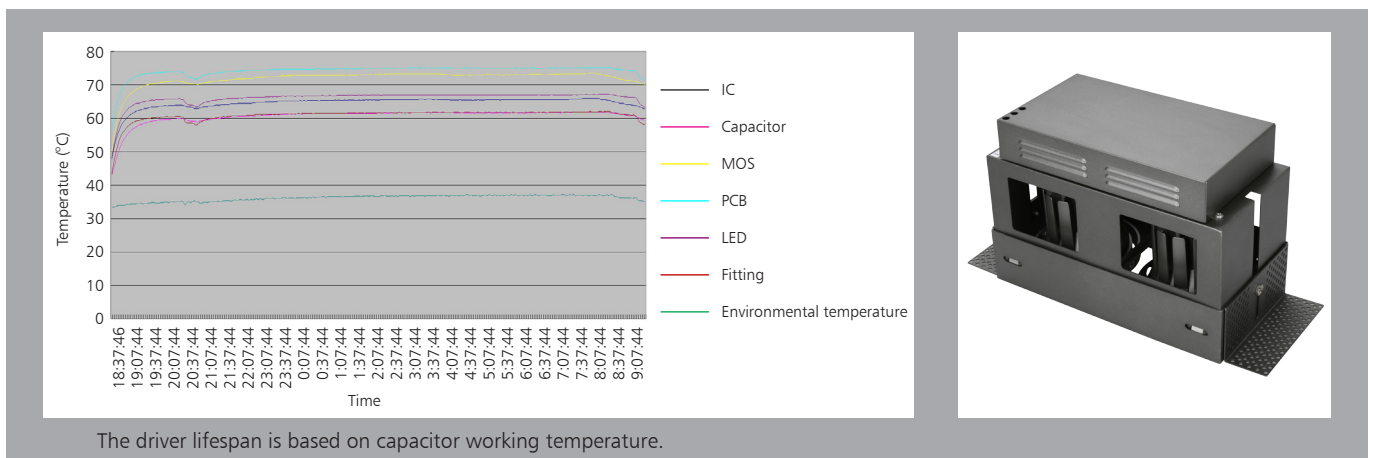

The driver lifespan is based on capacitor working temperature.



Installation

WARNING

1. Switch off before installation.
2. Switch on only after complete installation and examination of the circuit.
3. Professional electrician for installation and maintenance only.

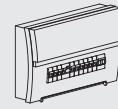

Step 1

Turn Off power supply before starting any installation. Read instructions & check you have all the tools & accessories to complete the installation correctly.

Step 2

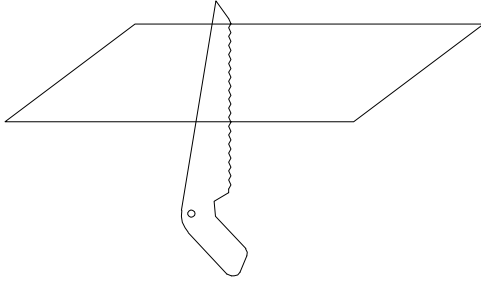

Open a hole on the ceiling according to cutout size of the lamp.

Step 3

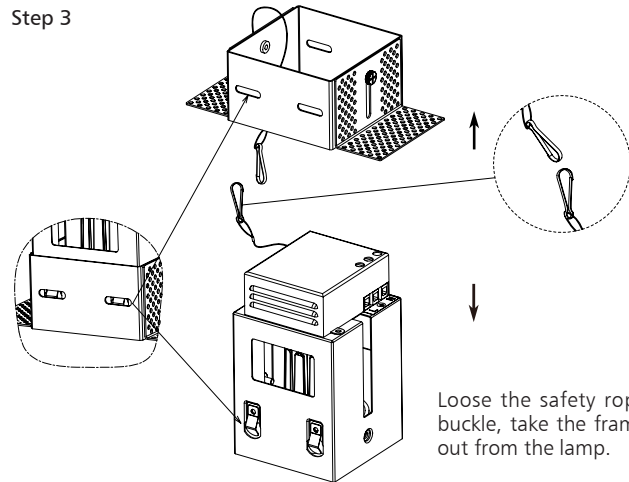

Loose the safety rope buckle, take the frame out from the lamp.

Step 4

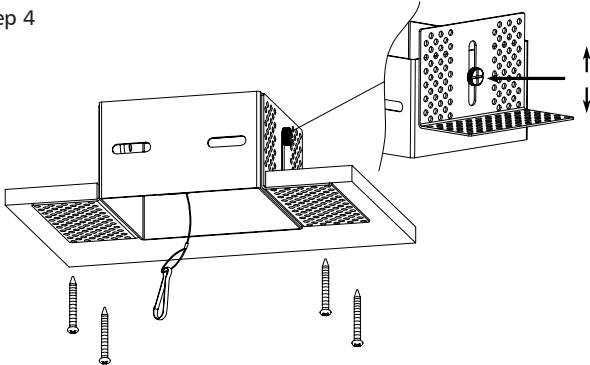

Screwed the frame on the ceiling, the height could be adjust through side screws.
Fix the frame on the ceiling by screw, adjust the frame height location by screw on the side.

Step 5

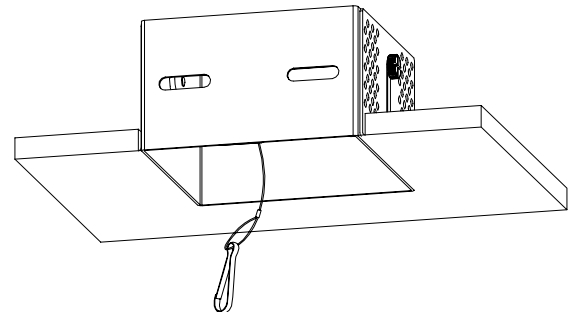

Decorate the ceiling by lime putty after fixing the frame.

Step 6

- L = SWITCHED
- E = EARTH
- N = NEUTRAL

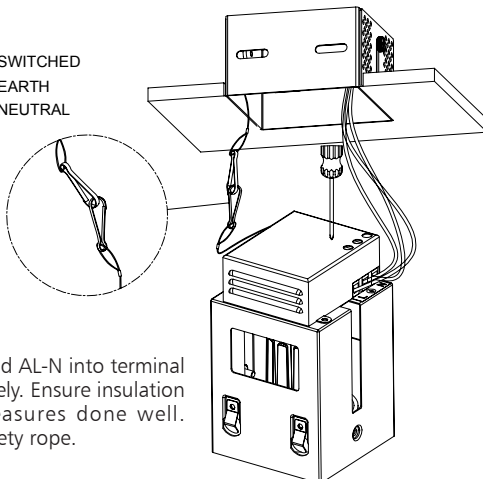

Locking AC-L and AL-N into terminal blocks respectively. Ensure insulation protection measures done well. Connect the safety rope.

Step 7

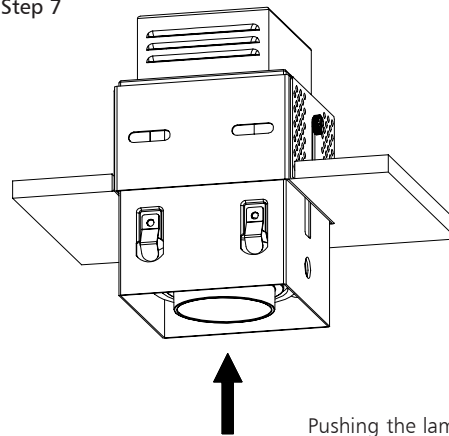

Pushing the lamps upward until it is fixed on the frame.

Step 8

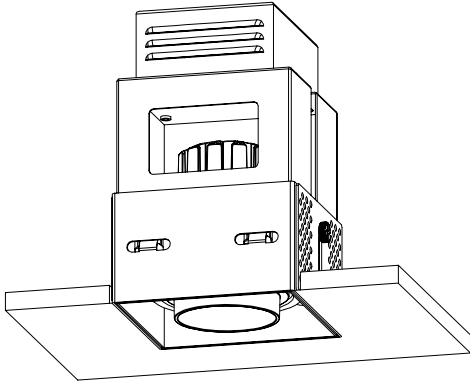

Install complete (figure 8), switch on.

Packaging Information

	SIZE(CM)	N.W/pc (KGS)	G.W.(KGS)	Q'TY(PCS)
Carton	46*34.5*39.5	2.5	17	6

	CTNS	Q'TY(PCS)	VOLUME(CBM)
20" standard container	439	2634	28
40" standard container	878	5268	56

