



UPSHINE®



Technical Application
Guide for UP-SHINE
LED Downlight
UP-RD01-C-60W

Introduction



SMD Rectangular downlight achieves high lumen output, 90° wide beam angle. AL6063 Aluminum profile provides excellent thermal dissipation. External driver solution achieves stable working performance and easy maintenance. Tilt head provides various lighting direction for different applications. Widely used for different commercial lighting situation.

- Up to 70% energy saving compared to standard CFL
- Long lifetime of 40,000 hours
- 90° wide beam angle
- L225XW130mm cutout
- CCT: 3000K 4000K
5000K 5700K
- No UV/IR light
- Environment friendly, without Mercury or any other hazardous substances

Application notes

- IP20 for indoor use only
- Professional electrician for installation only
- Switch off before installation
- Do not touch when in use
- Keep away from hot steam and corrosive gas

Application Areas

It is designed for general lighting applications in office, supermarket, shop, school, hotel, etc. It is also widely used for public areas, such as stairway, lobby, reception, corridors etc.

Certificate

CE RoHS SAA



Product Information

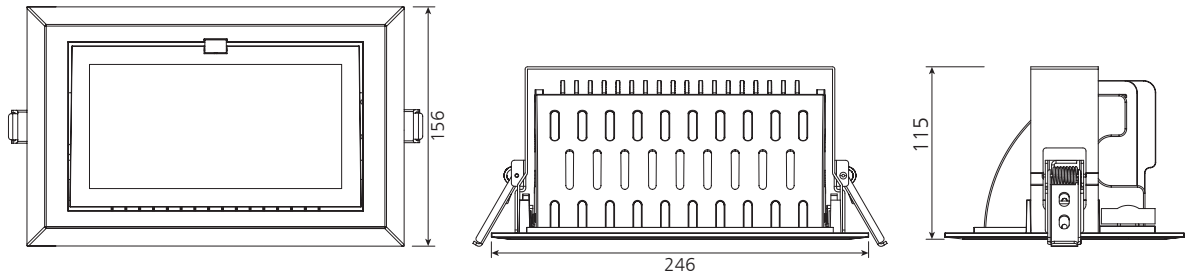

Technical Specifications

Model	Voltage	Power	Power Factor	Lumen (±5%)	CCT	Beam angle	Lifespan	CRI	Dimmable	Dimension
UP-RD01-C-60W	AC230V	60W	≥0.9	5300	3000K	90°	40000h	≥80	No	L246*W156*H155mm cutout L225*W130mm
				5350	4000K					
				5400	5000K					
				5450	5700K					

Driver data Sheet

Driver data	Non-dim
Input rated Voltage	AC230V
Frequency	50HZ
Input Voltage	AC200-240V
Efficiency	≥85%
Total load Wattage	60W±5%
Power Factor	≥0.9
Rated input current	≤0.34A
Full load output Voltage range	DC35-38V
Rated output current	1400mA
Output current range	1400mA±5%
Power tolerance	±5%
Current output tolerance	±5%
Short circuit protection	PASS
Over voltage protection	PASS
Over temperature protection	PASS
Withstand voltage	AC3750V

Fixture Compatibility

Rated Wattage	Electrical Classification	Ingress Protection	Operating Temp	Operating Humidity	Storage Temp
60W	II	IP20	-20°C~45°C	0~90%	-20°C~65°C

Spectral Distribution

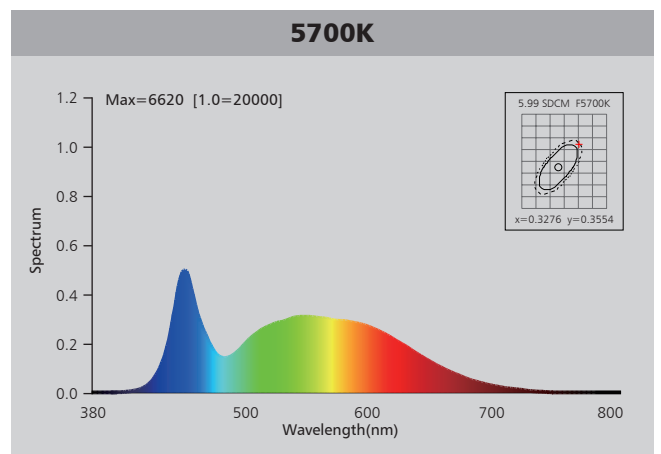
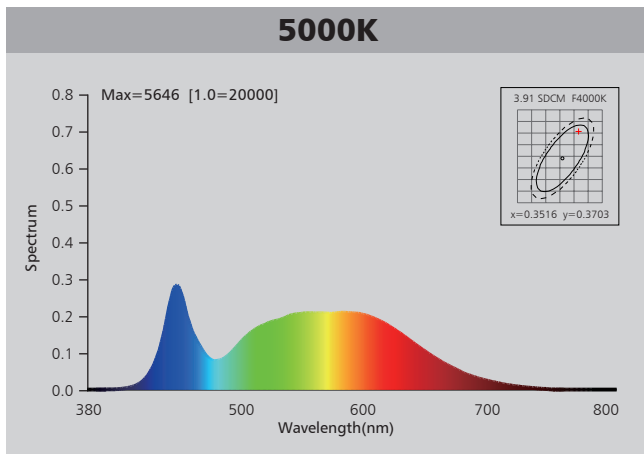
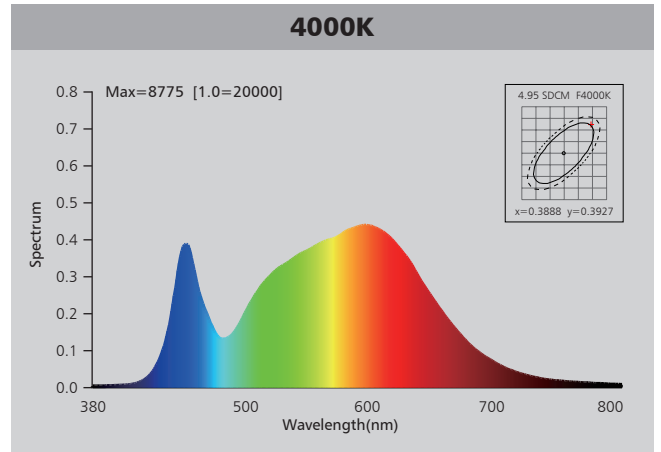
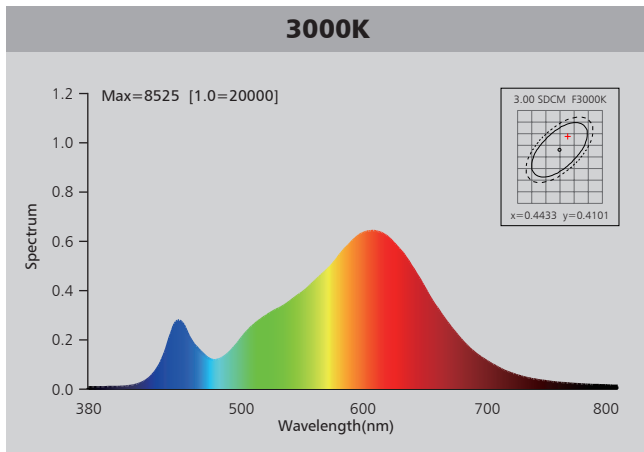

Photometric Diagram

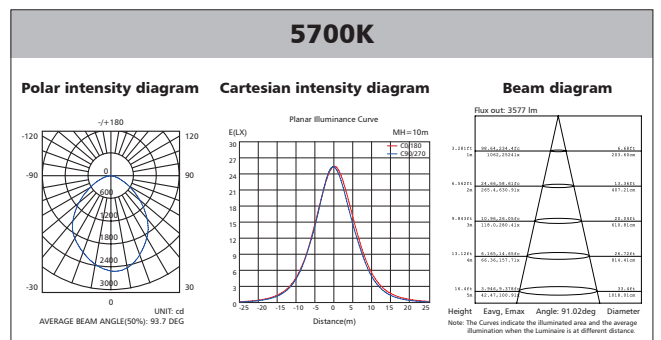
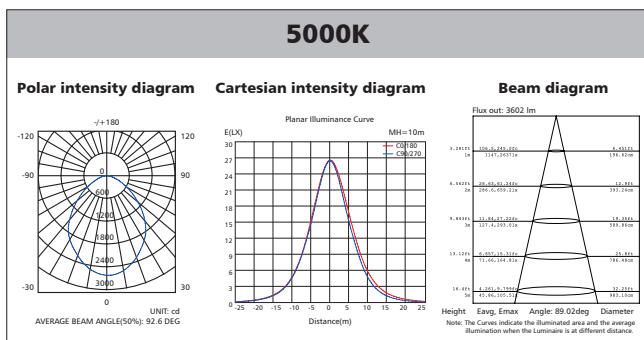
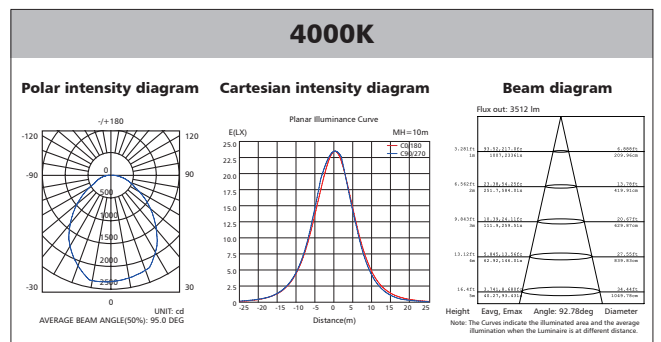
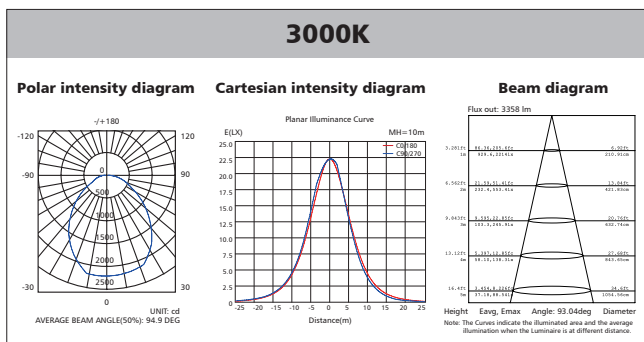

Polar Diagram Comparison

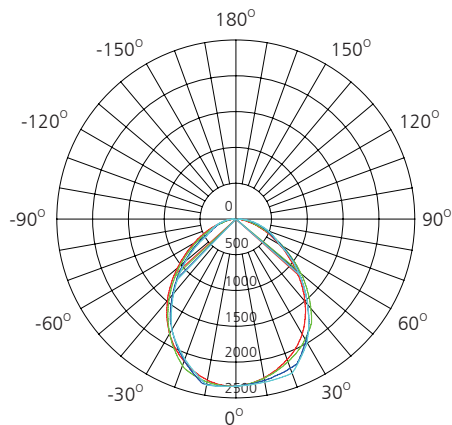

UNIT: cd

- C0/180, 95.8 deg
- C30/210, 97.2 deg
- C60/240, 93.8 deg
- C90/270, 93.0 deg



AVERAGE BEAM ANGLE (50%): 95.0DEG

Driver lifetime & LED light decay rate

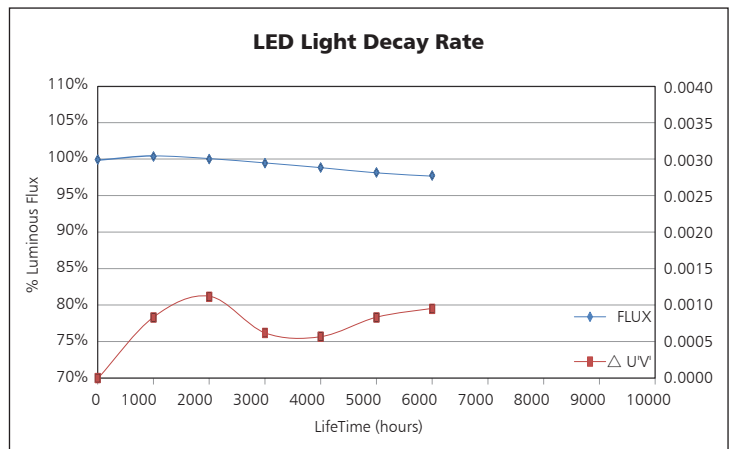
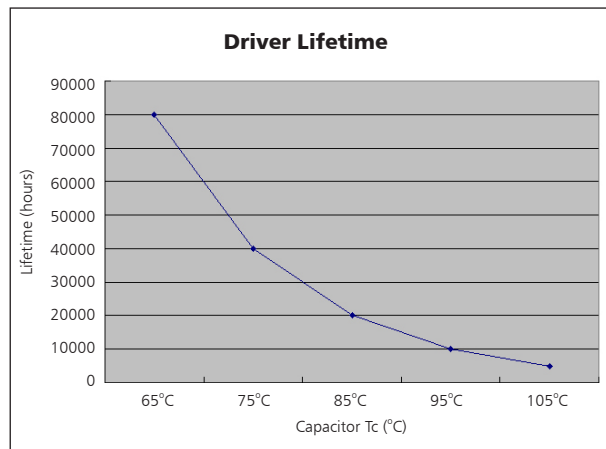

Temperature

- The testing is operated at 25°C
- The lifetime of capacitor, minimum of 5,000 hours if operated at 105°C, will be doubled whenever the temperature drops 10°C
- The highest withstand temperature of IC, MOS could be 120°C
- The highest withstand temperature of LED junction temperature is 150°C

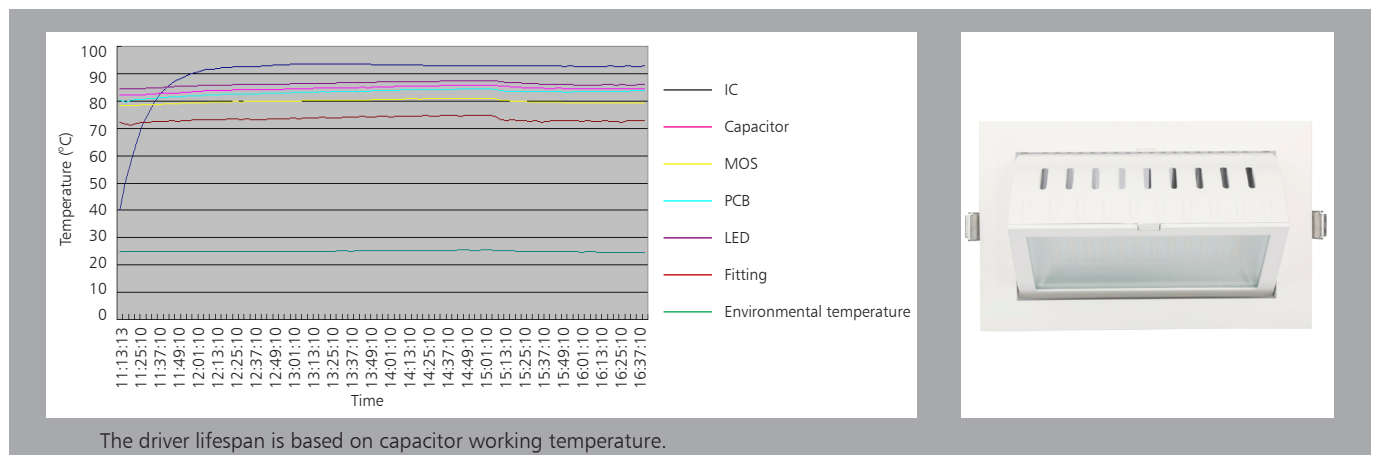

The driver lifespan is based on capacitor working temperature.



Installation

Install requirements	
A-gap above the fitting	25mm
B-gap to the building material	25mm
C-gap to the thermal insulation	25mm

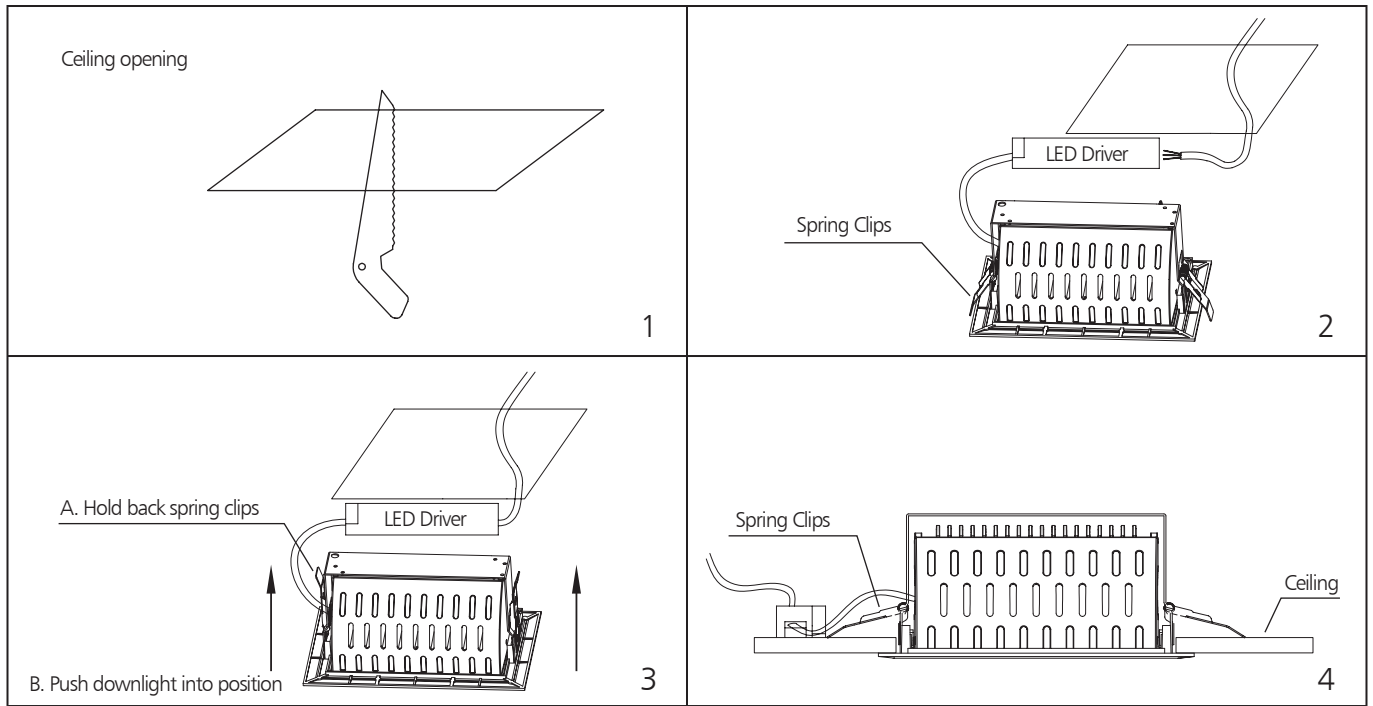
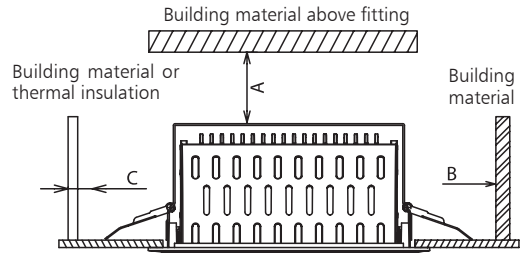

Packaging Information

	SIZE(CM)	N.W/pc (KGS)	G.W.(KGS)	Q'TY(PCS)
Carton	60*29*41.5	2.4	16.5	6

	CTNS	Q'TY(PCS)	VOLUME(CBM)
20" standard container	382	2292	28
40" standard container	764	4584	56

