



Up-shine<sup>®</sup> Lighting



Technical Application  
Guide for UP-SHINE  
LED Downlight  
UP-DL97-4-15W-B1



# Introduction



Up-shine LED downlight with bluetooth wireless control system offers consumers an easy, convenient, and cost-effective way to personalize and control a home lighting system. The control system use bluetooth technology to connect lights throughout an entire home via a free APP on a Bluetooth-enabled smart device. No wires, no router, no remote, and no Wi-Fi signal is needed. A user can simply control downlight from any Bluetooth-enabled phone or tablet and then personalize it to meet any family or lifestyle needs. The system also allows multiple devices to be connected simultaneously so the entire family can stay connected.

- Up to 80% energy saving compared to standard CFL
- Long lifetime of 50,000 hours ( 25°C )
- 90° wide beam angle
- Ø120-130mm cutout
- Bluetooth
- No UV/IR light
- Environment friendly, without Mercury or any other hazardous substances
- External driver

## Application notes

- IP54 for indoor use only
- Professional electrician for installation only
- Switch off before installation
- Do not touch when in use
- Keep away from hot steam and corrosive gas

## Application Areas

It is designed for general lighting applications in office, supermarket, shop, school, hotel, etc. It is also widely used for public areas, such as stairway, lobby, reception, corridors etc.

## Certificates



GooglePlay



APP STORE

# Bluetooth Intelligent Control

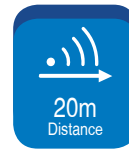
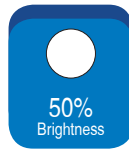
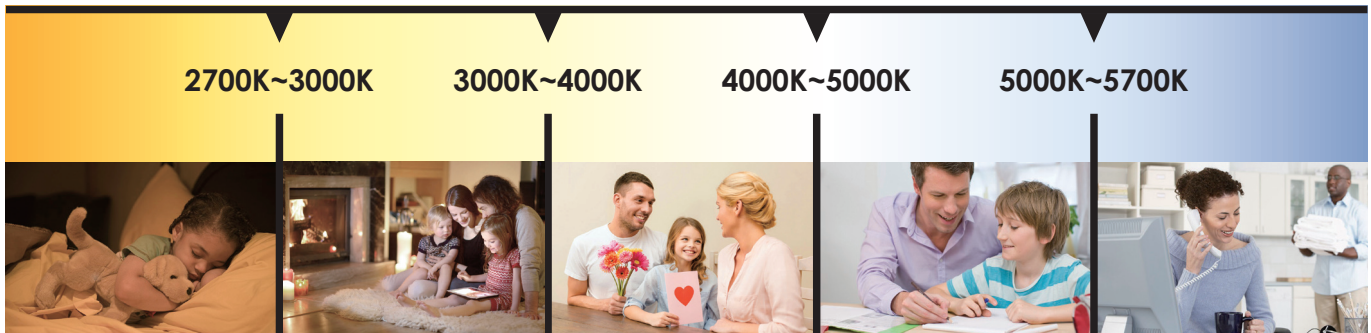



**2700K~5700K  
Color Changeable**

Creating fantastic atmosphere by flexible CCT changing between warm white, natural white and day light, the color changing items are controlled by wall touch switch or smart phone APP.





**8%~100%  
Dimmable**

Dimmable from 8%~100% brightness with timing and night lamp function, diversified scene setting, creating a humanized smart control system.



# Product Information

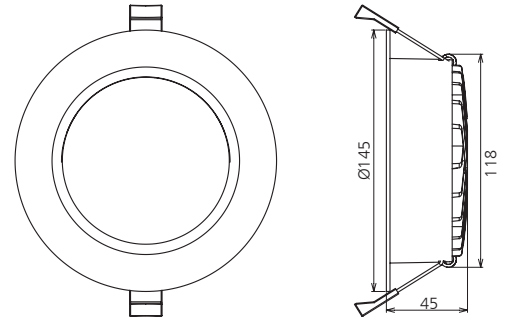

## Technical Specifications

Model	Voltage	Power	Power Factor	Lumen (±5%)	Beam angle	CCT	Lifespan	CRI	Dimmable	Dimension
UP-DL97-4-15W-B1	AC230V	15W	≥0.9	1200 ⋮ 1430 ⋮ 1280	90°	2700K ⋮ 4000K ⋮ 5700K	50000h	≥80	Yes	Ø145*45mm cutout 120-130mm

## Driver data Sheet

Driver data	DIM
Input rated Voltage	AC230V
Frequency	50Hz
Input Voltage	AC200-240V
Efficiency	≥83%
Total load Wattage	15W±1W
Power Factor	≥0.9
Rated input current	≤0.09A
Full load output Voltage	DC25-38V
Rated output current	350mA
Output current range	350mA±5%
Power tolerance	±5%
Current output tolerance	±5%
Dimming range	8%-100%
Dimmer	Triac dimmers
Short circuit protection	PASS
Over voltage protection	PASS
Over temperature protection	PASS
THD	≤18%
Withstand voltage	AC3750V

## Fixture Compatibility

Rated Wattage	Electrical Classification	Ingress Protection	Operating Temp	Operating Humidity	Storage Temp
15W	II	IP54	-20°C~45°C	0~90%	-20°C~65°C

# Spectral Distribution

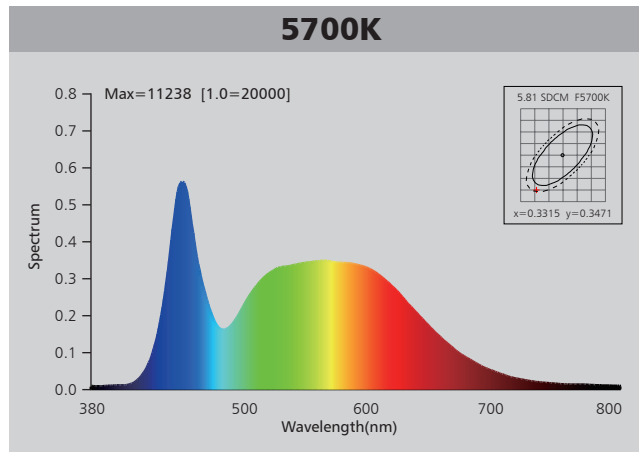
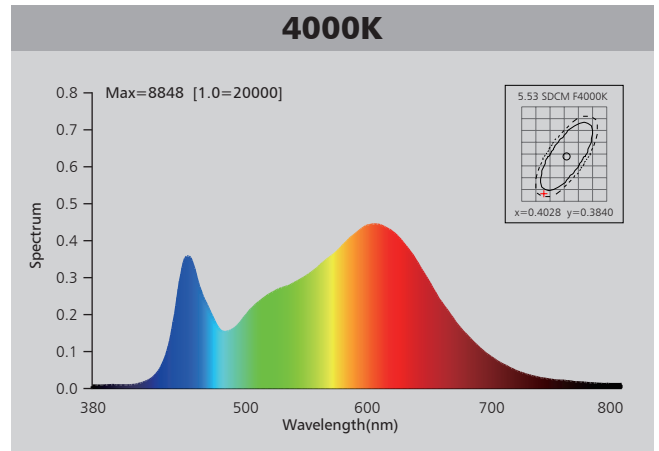
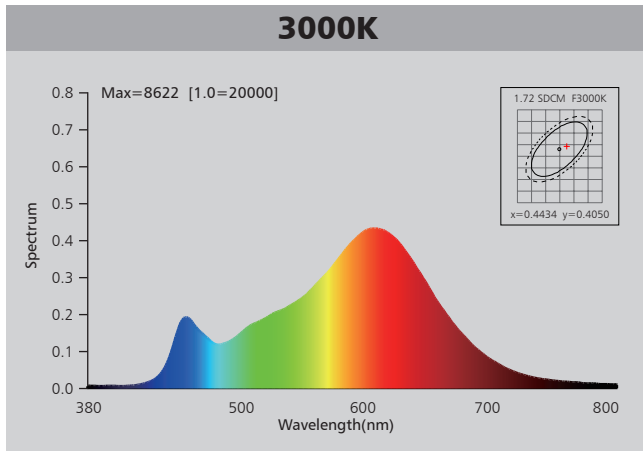

# Photometric Diagram

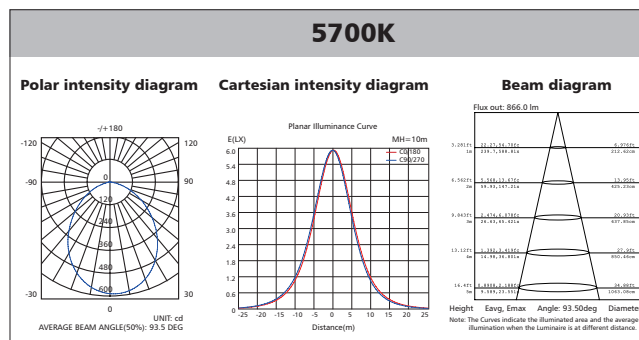
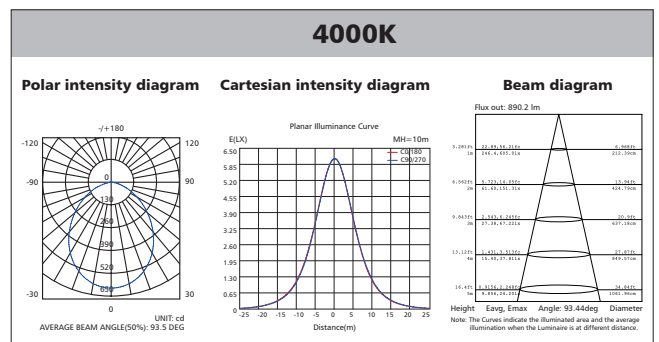
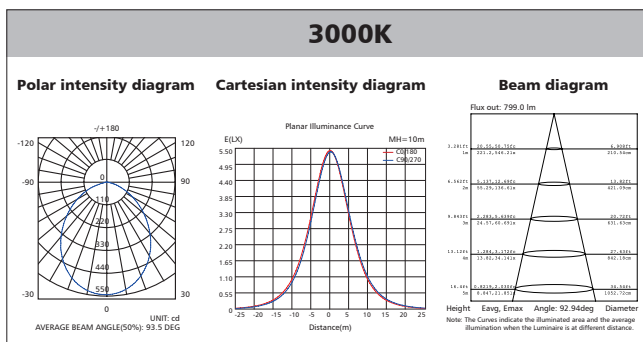



## Polar Diagram Comparison

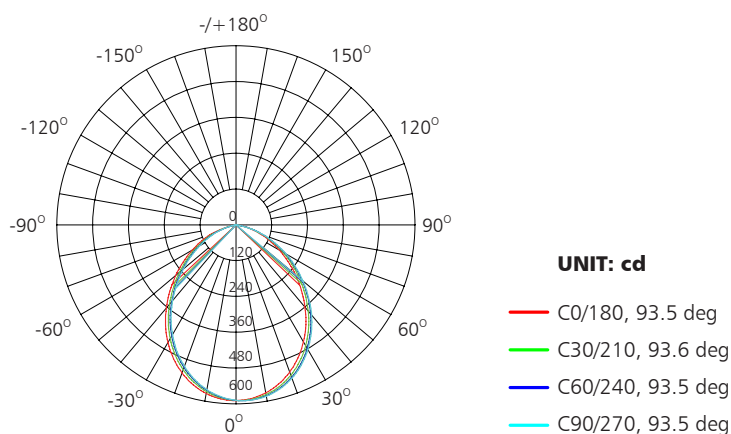

AVERAGE BEAM ANGLE (50%): 93.5DEG



## Driver lifetime & LED light decay rate

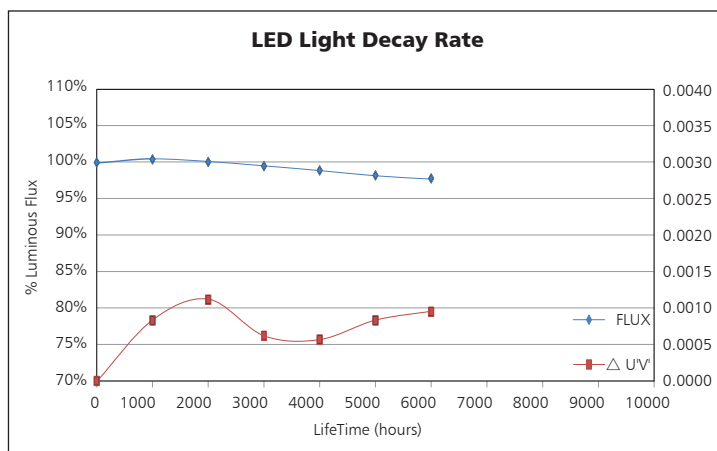
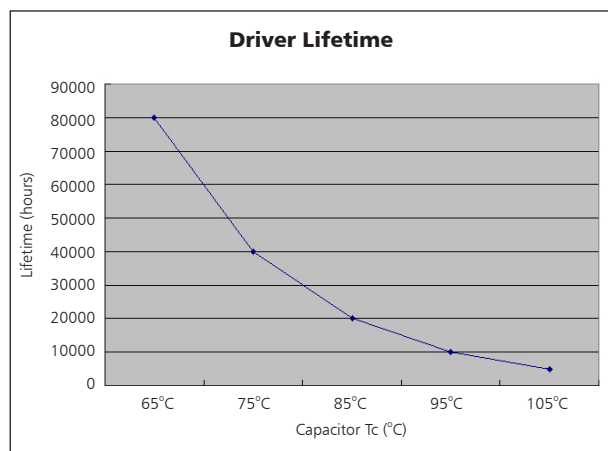

## Temperature

- The testing is operated at 25°C
- The lifetime of capacitor, minimum of 5,000 hours if operated at 105°C, will be doubled whenever the temperature drops 10°C
- The highest withstand temperature of IC, MOS could be 120°C
- The highest withstand temperature of LED junction temperature is 150°C

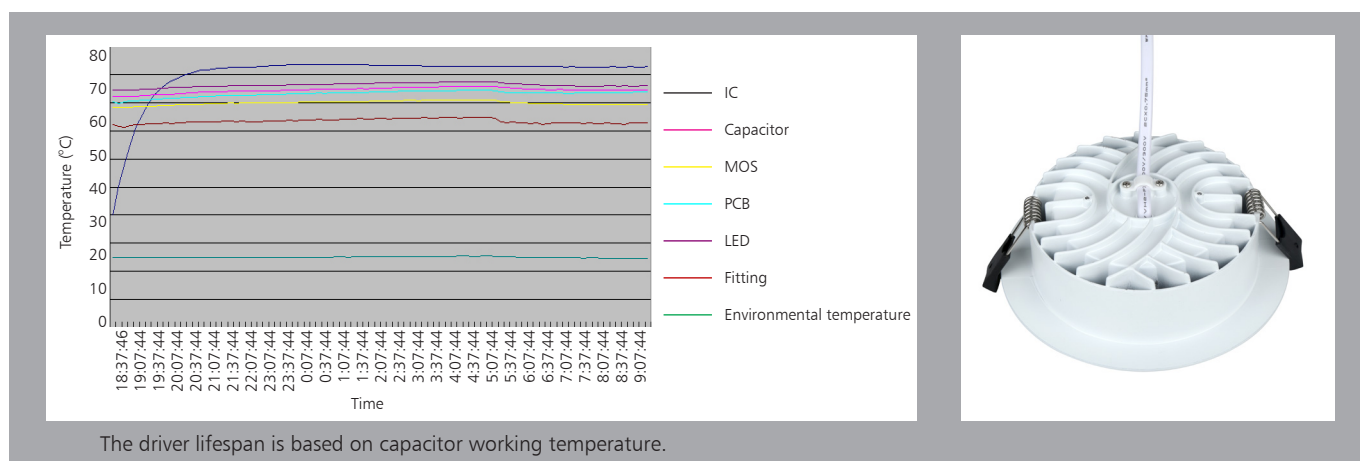

The driver lifespan is based on capacitor working temperature.

# Installation

Install requirements	
A-gap above the fitting	25mm
B-gap to the building material	25mm
C-gap to the thermal insulation	25mm

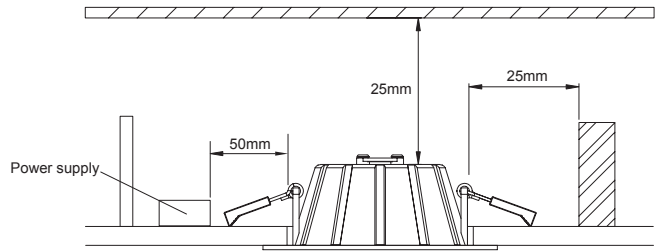

1. Open a hole according to the cutout size of led downlight.

2. Use screw-driver to open the driver terminal cover, feed the main AC wire L. N. in terminal block respectively, then fix the cover back.

3. Connect the downlight with driver, hold back the spring clip then push the downlight into the hole.

4. Make sure the downlight fixed tightly in ceiling, turn on the power (Fig 1).

# Packaging Information

	SIZE(CM)	N.W/pc (KGS)	G.W.(KGS)	Q'TY(PCs)
Carton	49*33*48	0.45	17.5	30

	CTNS	Q'TY(PCs)	VOLUME(CBM)
20" standard container	356	10680	28
40" standard container	712	21360	56

