



UPSHINE[®]



Technical Application
Guide for UP-SHINE
LED Downlight

UP-DL96-3-10W

Introduction



It's an ultra thin integrated anti-glare grilling lens downlight. The height is less than 40mm with built-in driver, suitable for various applications. Grilling design effectively reduce the UGR index. Luminous efficiency 110lm/w. Equipped with push button looping connection terminal (LL-NN-EE), the simple structure provides easy access to installation and high security.

- Up to 70% energy saving compared to standard CFL
- Long lifetime of 40,000 hours
- Triac dim
- 90°wide beam angle
- 90-95mm cutout
- CCT: 3000K 4000K 5000K 5700K
- No UV/IR light
- Environment friendly, without Mercury or any other hazardous substances

Application notes

- IP54 at room side for indoor use only
- Professional electrician for installation only
- Switch off before installation
- Do not touch when in use
- Keep away from hot steam and corrosive gas

Application Areas

It is designed for general lighting applications in office, supermarket, shop, school, hotel, etc. It is also widely used for public areas, such as stairway, lobby, reception, corridors etc.

Certificate

CE RoHS SAA



Product Information

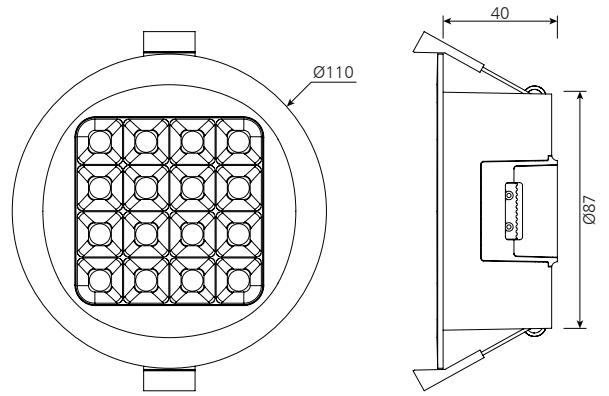

Technical Specifications

Model	Voltage	Power	Power Factor	Lumen (±5%)	Beam angle	CCT	Lifespan	CRI	Dimmable	Dimension
UP-DL96-3-10W	AC100-277V	10W	≥0.9	1000	90°	3000K	40000h	≥80	No	Ø110*40mm cutout 90-95mm
UP-DL96-3-10W	AC100-277V	10W	≥0.9	1050	90°	4000K	40000h	≥80	No	Ø110*40mm cutout 90-95mm
UP-DL96-3-10W	AC100-277V	10W	≥0.9	1070	90°	5000K	40000h	≥80	No	Ø110*40mm cutout 90-95mm
UP-DL96-3-10W	AC100-277V	10W	≥0.9	1070	90°	5700K	40000h	≥80	No	Ø110*40mm cutout 90-95mm
UP-DL96-3-10W-D	AC230V	10W	≥0.9	980	90°	3000K	40000h	≥80	Yes	Ø110*40mm cutout 90-95mm
UP-DL96-3-10W-D	AC230V	10W	≥0.9	1020	90°	4000K	40000h	≥80	Yes	Ø110*40mm cutout 90-95mm
UP-DL96-3-10W-D	AC230V	10W	≥0.9	1050	90°	5000K	40000h	≥80	Yes	Ø110*40mm cutout 90-95mm
UP-DL96-3-10W-D	AC230V	10W	≥0.9	1050	90°	5700K	40000h	≥80	Yes	Ø110*40mm cutout 90-95mm

Driver data Sheet

Driver data	DIM	Non dim
Input rated Voltage	AC230V	AC100-277V
Frequency	50Hz	50/60Hz
Input Voltage	AC200-240V	AC90-305V
Efficiency	≥80%	≥85%
Total load Wattage	10W±1W	10W±1W
Power Factor	≥0.9	≥0.9
Rated input current	≤0.06A	≤0.15A
Full load output Voltage	DC40-50V	DC40-58V
Rated output current	170mA	190mA
Output current range	170mA±5%	190mA±5%
Power tolerance	±5%	±5%
Current output tolerance	±5%	±5%
Dimming range	8%-100%	—
Dimmer	Triac dimmers	—
Short circuit protection	PASS	PASS
Over voltage protection	PASS	PASS
Over temperature protection	PASS	PASS
THD	≤20%	≤20% (@230V)
Flick free	No	Yes
Withstand voltage	—	—

Fixture Compatibility

Rated Wattage	Electrical Classification	Ingress Protection	Operating Temp	Operating Humidity	Storage Temp
10W	I	IP54	-20°C~45°C	0~90%	-20°C~65°C

Spectral Distribution

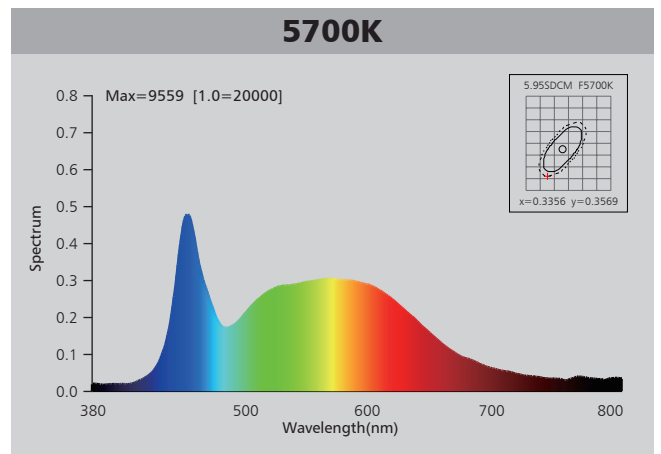
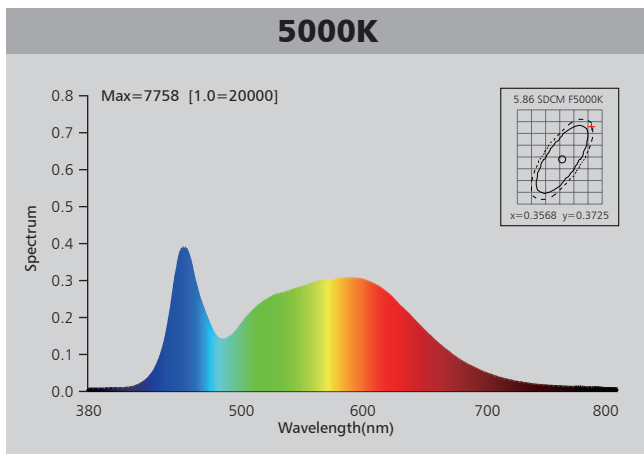
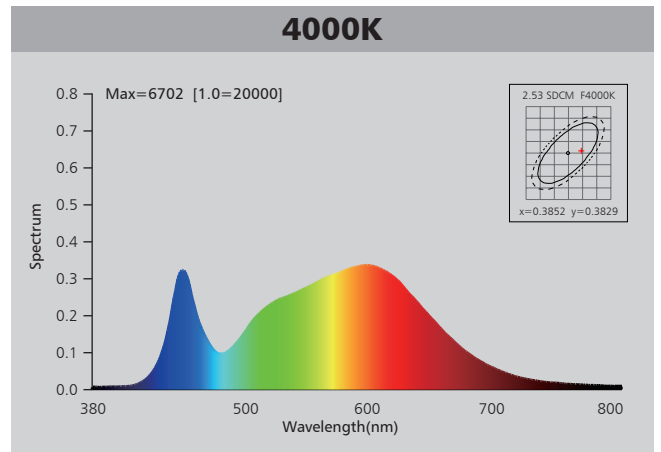
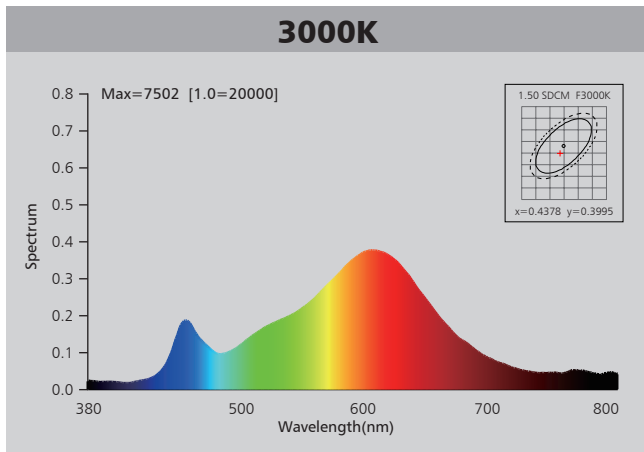

Photometric Diagram

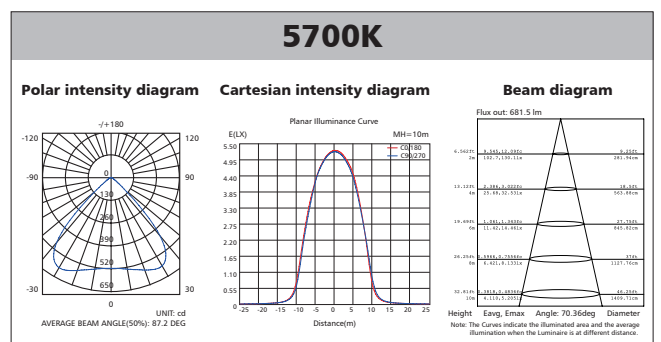
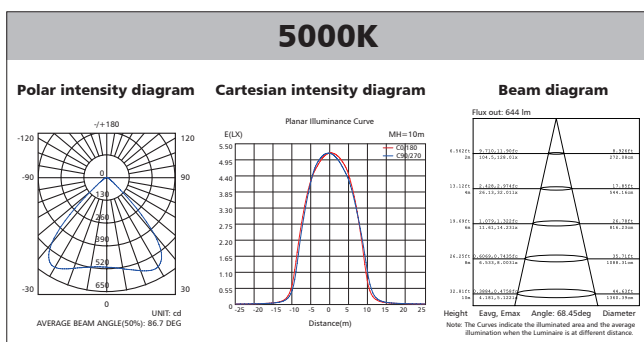
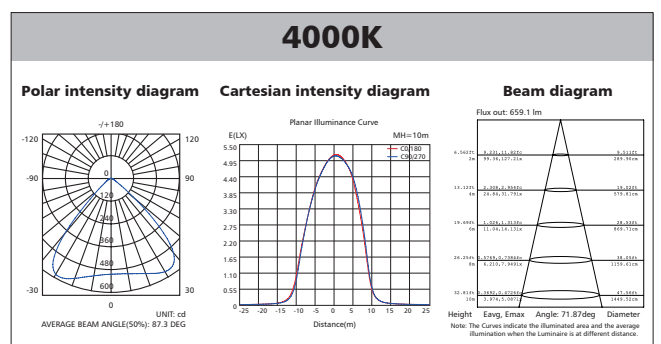
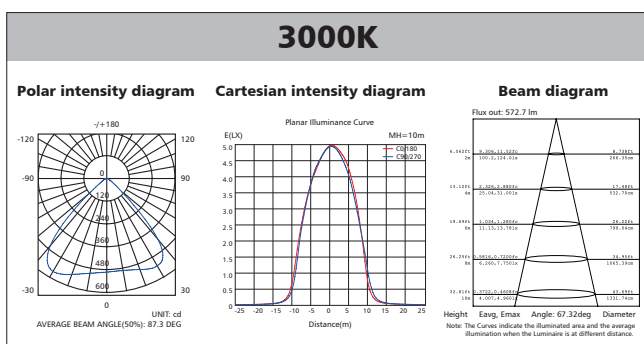

Polar Diagram Comparison

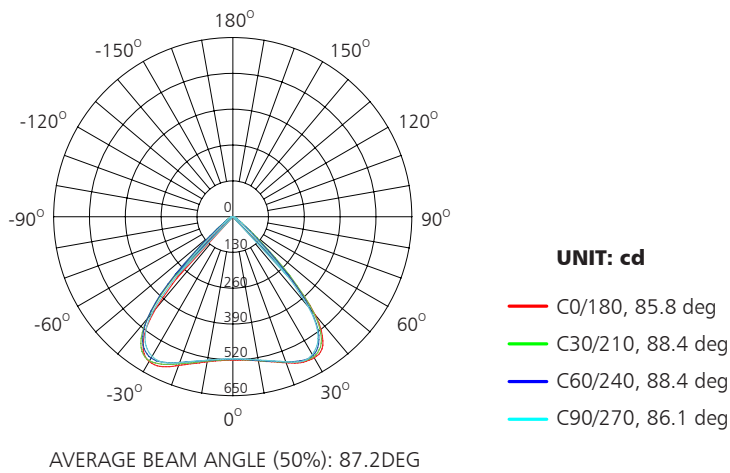

Driver lifetime & LED light decay rate

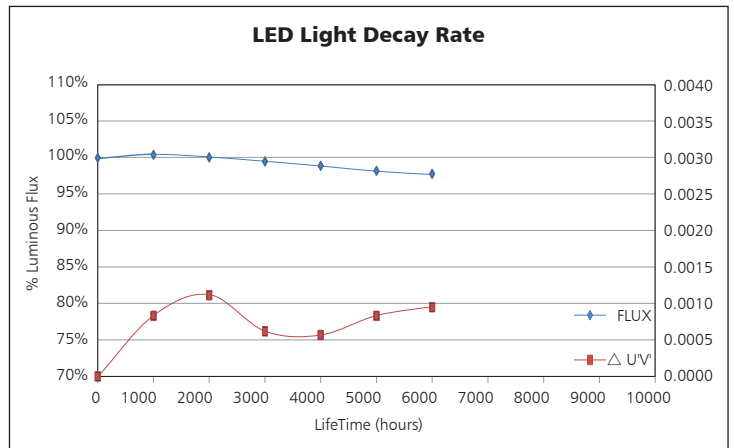
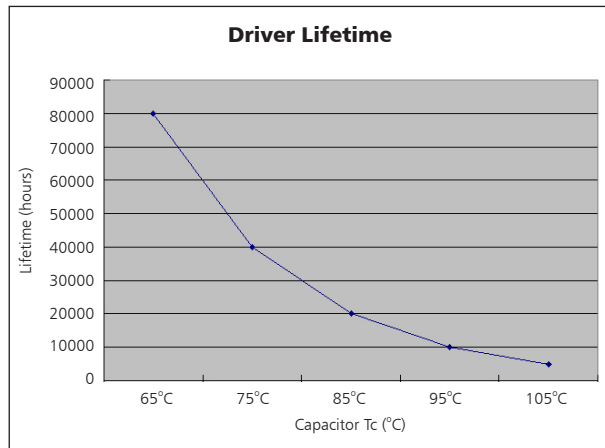

Temperature

- The testing is operated at 25°C
- The lifetime of capacitor, minimum of 5,000 hours if operated at 105°C, will be doubled whenever the temperature drops 10°C.
- The highest withstand temperature of IC, MOS could be 120°C
- The highest withstand temperature of LED junction temperature is 150°C

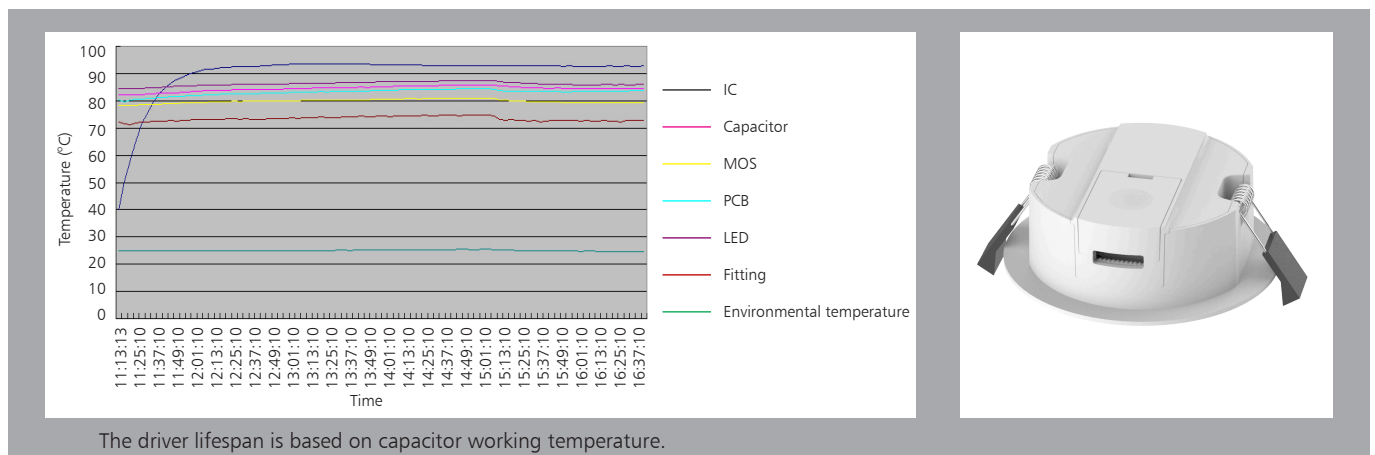

Installation Procedure

WARNING

1. Switch off before installation.
2. Switch on only after complete installation and examination of the circuit.
3. Professional electrician for installation and maintenance only.

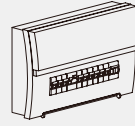

**Turn Off
Power Supply**

Turn Off power supply before starting any installation. Read instructions & check you have all the tools & accessories to complete the installation correctly.

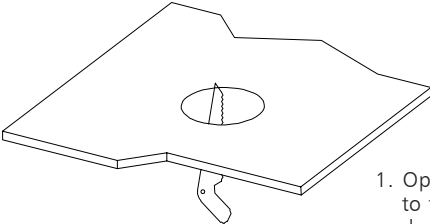
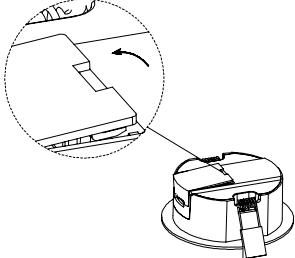
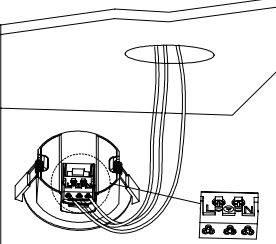
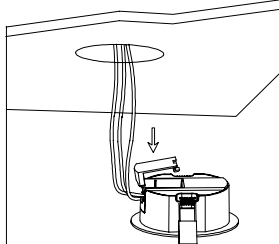
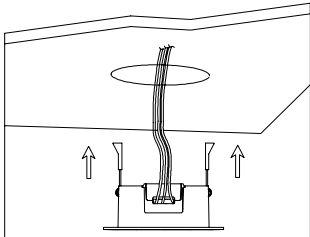
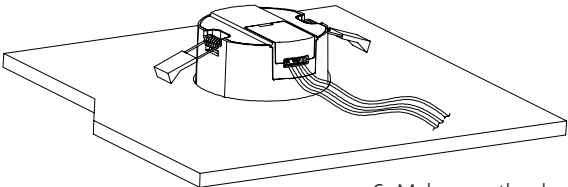
 <p>1. Open a hole according to the cutout size of led downlight.</p>	 <p>2. Open the driver cover.</p>
 <p> L = Brown ⊕ = EARTH N = Blue </p> <p>3. Feed the main AC wire L.N to the fast connection terminal block respectively.</p>	 <p>4. Fix the cover back.</p>
 <p>5. Hold back spring clips then push downlight into the hole.</p>	 <p>6. Make sure the downlight fixed tightly in ceiling, turn on the power.</p>

Packaging Information

	SIZE(CM)	N.W/pc (KGS)	G.W.(KGS)	Q'TY(PCS)
Carton	36.5*25*33	0.22	9.5	30

	CTNS	Q'TY(PCS)	VOLUME(CBM)
20" standard container	900	27000	28
40" standard container	1800	54000	56

