



Up-shine[®] Lighting



Technical Application
Guide for UP SHINE
LED Downlight
UP-DL94-6-16W

Introduction

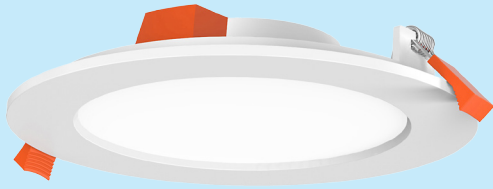

Up-shine ultra thin LED downlight DL94 model adopts side-emitting design, high lumen SMD LED, PMMA LGP with even light output. Equipped with aluminum heating sink, 94-V0 fire rated PC housing and internal driver. Dimmable version available, it shares great popularity by the excellent dimming effect. Up-shine ultra thin LED downlight is suitable for various applications perfectly even narrow and low ceiling.

- Up to 70% energy saving compared to standard CFL
- Long lifetime of 40,000 hours
- Triac dim
- 120° wide beam angle
- 160-170mm cutout
- CCT: 3000K 4000K
5000K 5700K
- No UV/IR light
- Environment friendly, without Mercury or any other hazardous substances

Application notes

- IP40 for indoor use only
- Professional electrician for installation only
- Switch off before installation
- Do not touch when in use
- Keep away from hot steam and corrosive gas

Application Areas

It is designed for general lighting applications in office, supermarket, shop, school, hotel, etc. It is also widely used for public areas, such as stairway, lobby, reception, corridors etc.

Certificate



RoHS



Product Information

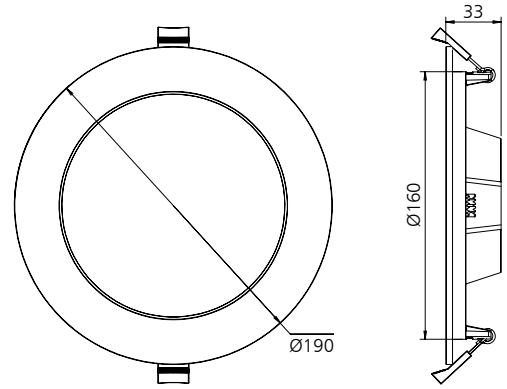

Technical Specifications

Model	Voltage	Power	Power Factor	Lumen (±5%)	Beam angle	CCT	Lifespan	CRI	Dimmable	Dimension
UP-DL94-6-16W	100-240V	16W	≥0.9	1580	120°	3000K	40000h	≥80	No	Ø190*33mm cutout 160-170mm
UP-DL94-6-16W	100-240V	16W	≥0.9	1700	120°	4000K	40000h	≥80	No	Ø190*33mm cutout 160-170mm
UP-DL94-6-16W	100-240V	16W	≥0.9	1720	120°	5000K	40000h	≥80	No	Ø190*33mm cutout 160-170mm
UP-DL94-6-16W	100-240V	16W	≥0.9	1730	120°	5700K	40000h	≥80	No	Ø190*33mm cutout 160-170mm
UP-DL94-6-16W-D	230V	16W	≥0.9	1470	120°	3000K	40000h	≥80	Yes	Ø190*33mm cutout 160-170mm
UP-DL94-6-16W-D	230V	16W	≥0.9	1590	120°	4000K	40000h	≥80	Yes	Ø190*33mm cutout 160-170mm
UP-DL94-6-16W-D	230V	16W	≥0.9	1600	120°	5000K	40000h	≥80	Yes	Ø190*33mm cutout 160-170mm
UP-DL94-6-16W-D	230V	16W	≥0.9	1610	120°	5700K	40000h	≥80	Yes	Ø190*33mm cutout 160-170mm

Driver data Sheet

Driver data	DIM	Non dim
Input rated Voltage	AC230V	AC100-240V
Frequency	50Hz	50/60Hz
Input Voltage	AC200-240V	AC85-265V
Efficiency	≥85%	≥85%
Total load Wattage	16W±1W	16W±1W
Power Factor	≥0.9	≥0.9
Rated input current	≤0.09A	≤0.18A
Full load output Voltage	DC55-65V	DC55-78V
Rated output current	240mA	250mA
Output current range	240mA±5%	250mA±5%
Power tolerance	±5%	±5%
Current output tolerance	±5%	±5%
Dimming range	8%-100%	—
Dimmer	Triac dimmers	—
Short circuit protection	PASS	PASS
Over voltage protection	PASS	PASS
Over temperature protection	PASS	PASS
THD	≤20%	≤20% @ 230V

Fixture Compatibility

Rated Wattage	Electrical Classification	Ingress Protection	Operating Temp	Operating Humidity	Storage Temp
16W	II	IP40	-20°C~45°C	0~90%	-20°C~65°C

Spectral Distribution

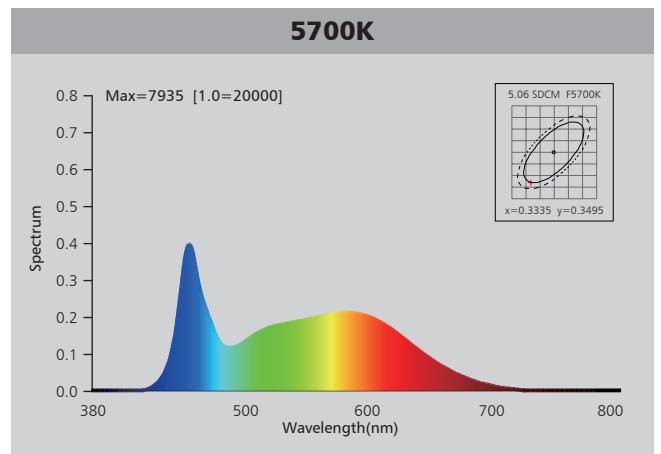
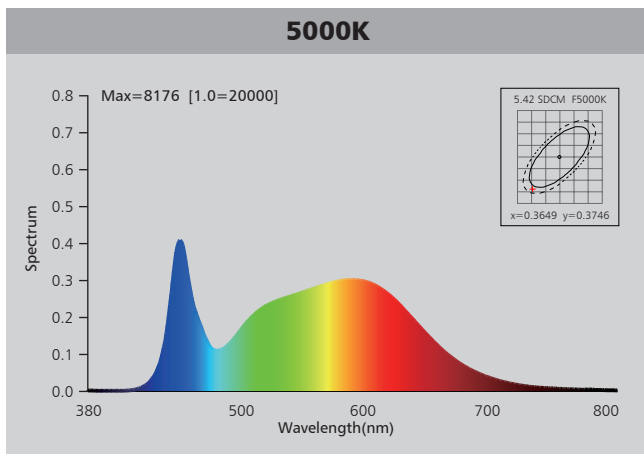
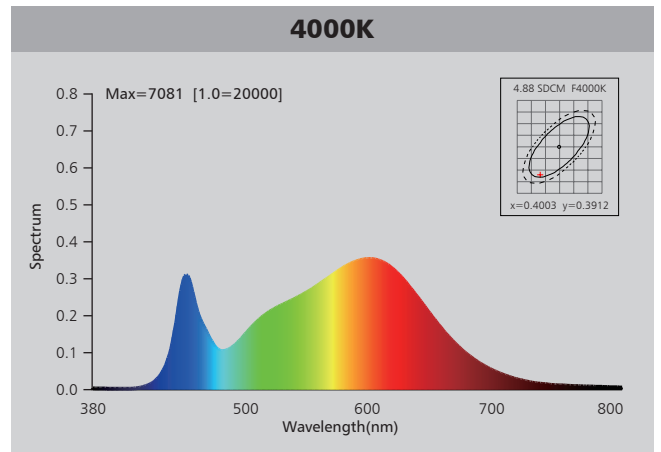
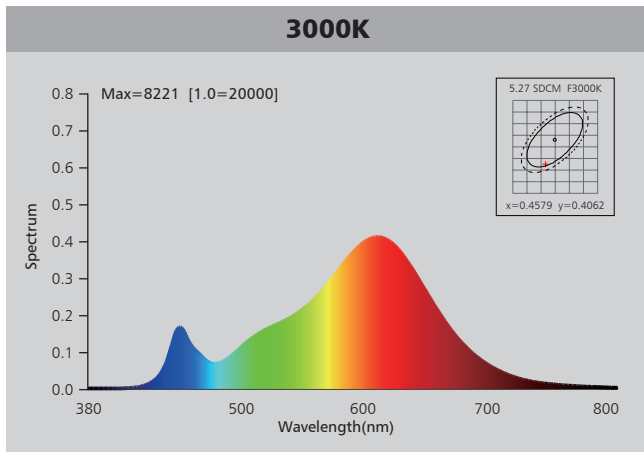

Photometric Diagram

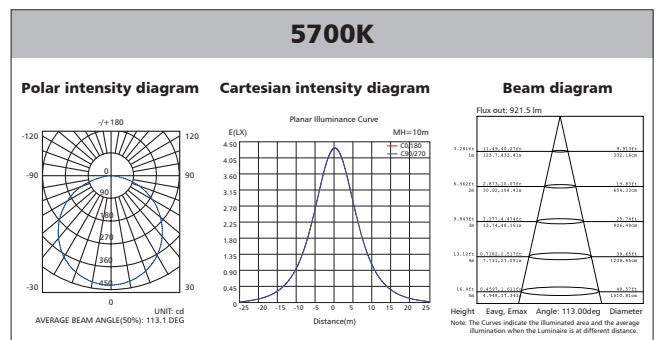
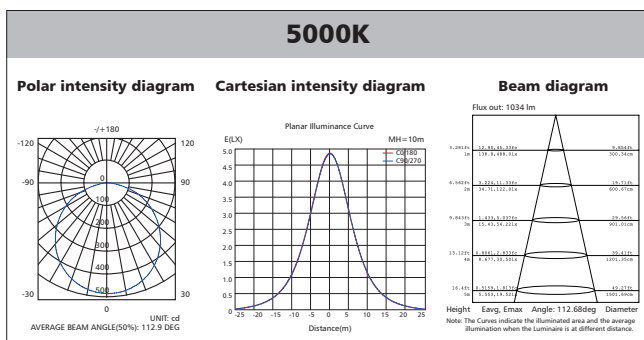
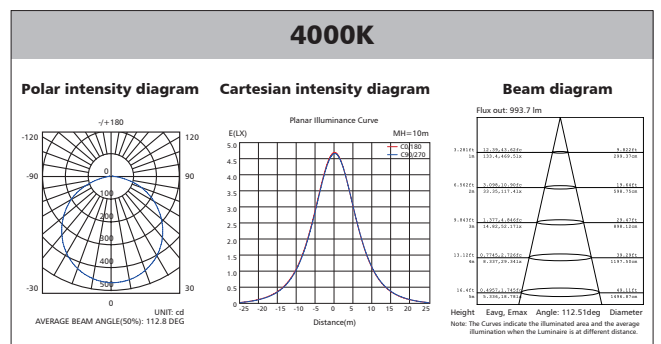
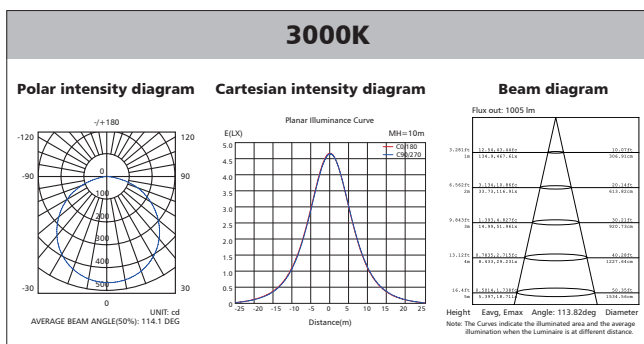

Polar Diagram Comparison

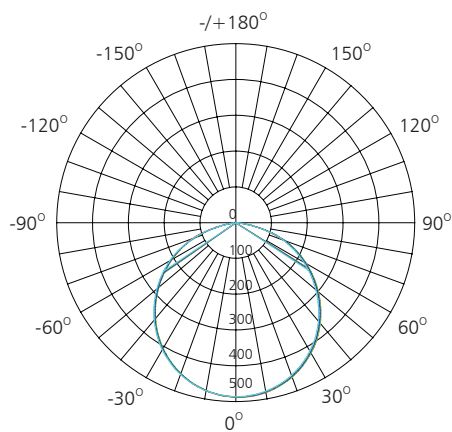

UNIT: cd

- C0/180, 112.9 deg
- C30/210, 113.0 deg
- C60/240, 113.0 deg
- C90/270, 112.9 deg



AVERAGE BEAM ANGLE (50%): 112.9 DEG

Driver lifetime & LED light decay rate

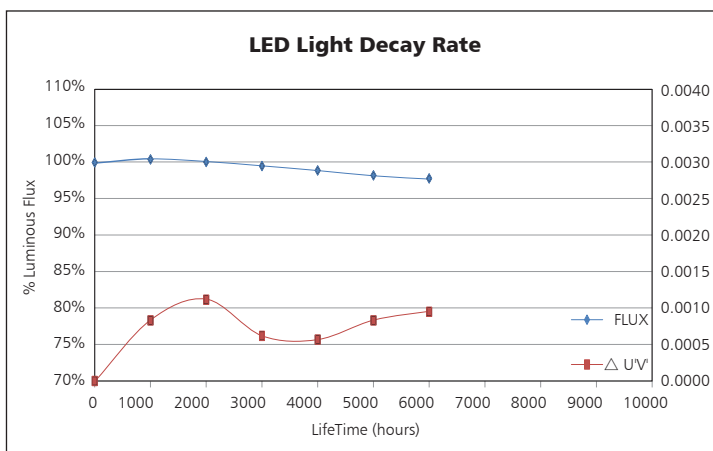
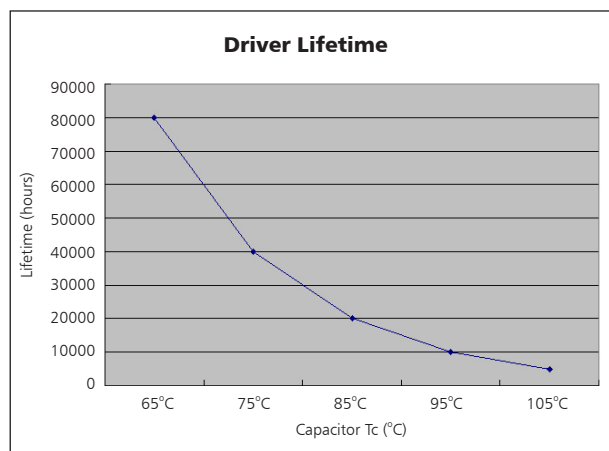

Temperature

- The testing is operated at 25°C
- The lifetime of capacitor, minimum of 5,000 hours if operated at 105°C, will be doubled whenever the temperature drops 10°C
- The highest withstand temperature of IC, MOS could be 120°C
- The highest withstand temperature of LED junction temperature is 150°C

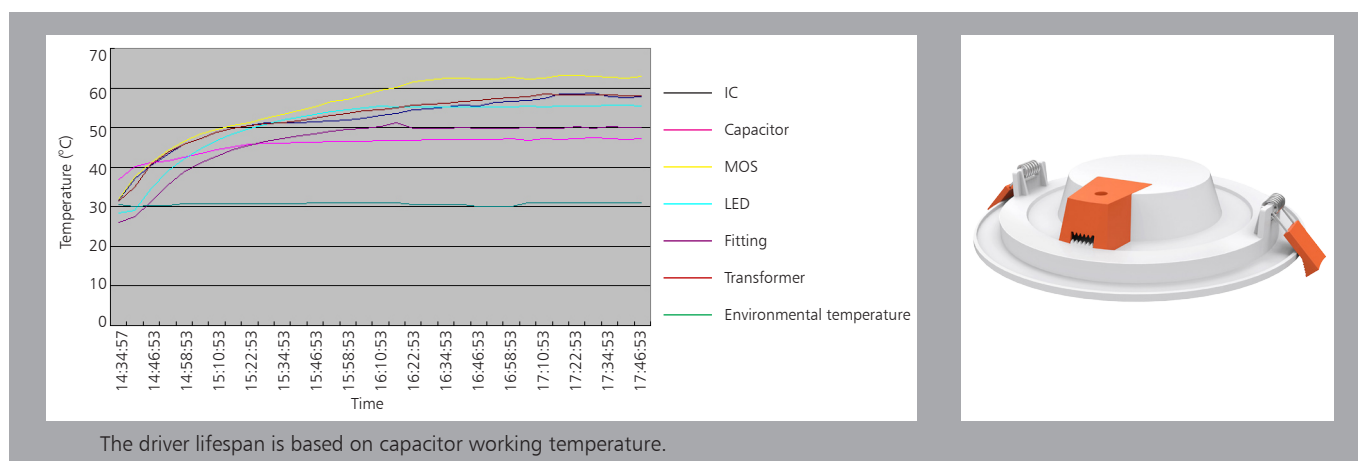

The driver lifespan is based on capacitor working temperature.

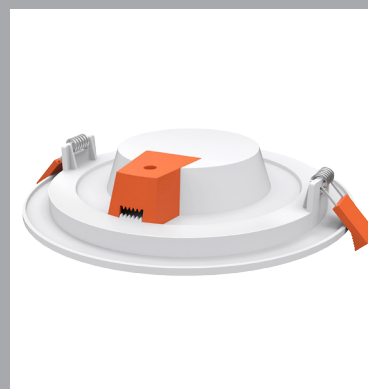

Installation

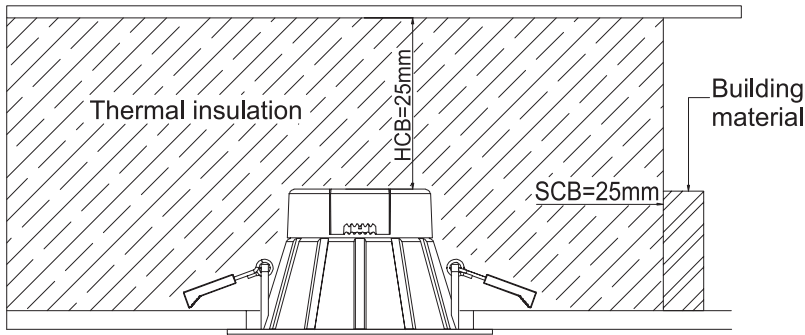

<p>1. Open a hole according to the cutout size of led downlight.</p>	<p>2. Use screw-driver to open the driver terminal cover on the back of downlight, feed the main AC wire L. N. in terminal block respectively, then fix the cover back.</p>
<p>3. Hold back the spring clip then push the downlight into the hole.</p>	<p>4. Make sure the downlight fixed tightly in ceiling, turn on the power (Fig 1).</p>

Packaging Information

	SIZE(CM)	N.W/pc (KGS)	G.W.(KGS)	QTY(PCS)
Carton	41*41*32	0.395	10.5	24

	CTNS	QTY(PCS)	VOLUME(CBM)
20" standard container	510	12240	28
40" standard container	1020	24480	56

