



Up-shine<sup>®</sup> Lighting



Technical Application  
Guide for UP-SHINE  
LED Downlight

UP-DL86-3-10W

# Introduction



DL86 is a LED downlight which comply with IC-4 certification requirements. Integrated driver structure is more convenient for installation. The front cover and heat sink is a whole entity which can improve heat dissipation performance. The front of lamp with slight curve surface design is not only with softer appearance but also a better sense of touch compared with similar products. IP54 waterproof from front side, it can be widely applied to damp applications.

- Up to 70% energy saving compared to standard CFL
- Long lifetime of 40,000 hours
- Dimmable with triac dimmer
- 100° wide beam angle
- 90-100mm cutout
- CCT: 3000K 4000K  
5000K 5700K
- No UV/IR light
- Environment friendly, without Mercury or any other hazardous substances

## Application notes

- IP54 for indoor use only
- Professional electrician for installation only
- Switch off before installation
- Do not touch when in use
- Keep away from hot steam and corrosive gas

## Application Areas

It is designed for general lighting applications in office, supermarket, shop, school, hotel, etc. It is also widely used for public areas, such as stairway, lobby, reception, corridors etc.

## Certificate

CE RoHS

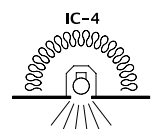

# Product Information

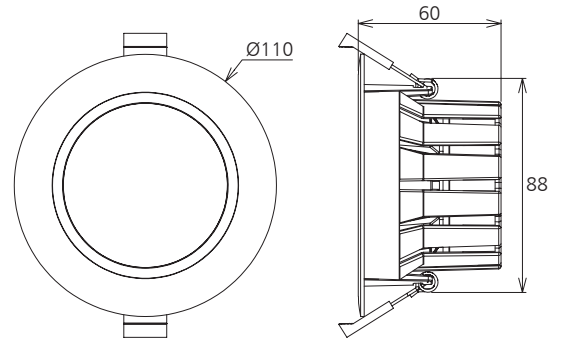

## Technical Specifications

Model	Voltage	Power	Power Factor	Lumen (±5%)	Beam angle	CCT	Lifespan	CRI	Dimmable	Dimension
UP-DL86-3-10W-D	AC230V	10W	≥0.9	770	100°	3000K	40000h	≥80	Yes	Ø110*60mm cutout 90-100mm
UP-DL86-3-10W-D	AC230V	10W	≥0.9	950	100°	4000K	40000h	≥80	Yes	Ø110*60mm cutout 90-100mm
UP-DL86-3-10W-D	AC230V	10W	≥0.9	890	100°	5000K	40000h	≥80	Yes	Ø110*60mm cutout 90-100mm
UP-DL86-3-10W-D	AC230V	10W	≥0.9	940	100°	5700K	40000h	≥80	Yes	Ø110*60mm cutout 90-100mm

## Driver data Sheet

Driver data	DIM
Input rated Voltage	AC230V
Frequency	50Hz
Input Voltage	AC200-240V
Efficiency	≥82%
Total load Wattage	10W±1W
Power Factor	≥0.9
Rated input current	≤0.06A
Full load output Voltage	DC65-75V
Rated output current	110mA
Output current range	110mA±5%
Power tolerance	±5%
Current output tolerance	±5%
Dimming range	8%-100%
Dimmer	Triac dimmers
Short circuit protection	PASS
Over voltage protection	PASS
Over temperature protection	PASS
Withstand voltage	—

## Fixture Compatibility

Rated Wattage	Electrical Classification	Ingress Protection	Operating Temp	Operating Humidity	Storage Temp
10W	II	IP54	-20°C~45°C	0~90%	-20°C~65°C

# Spectral Distribution

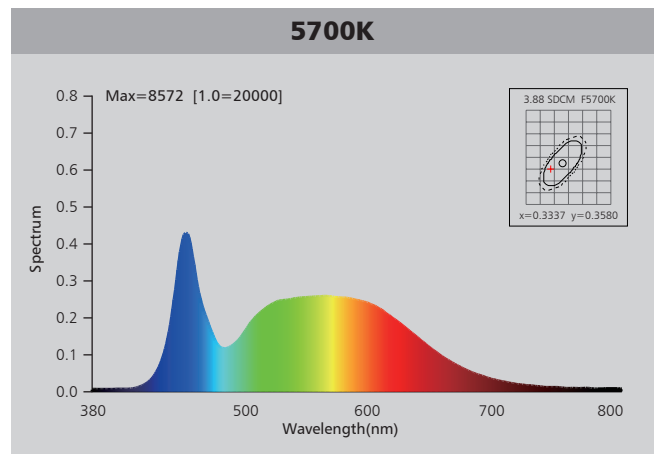
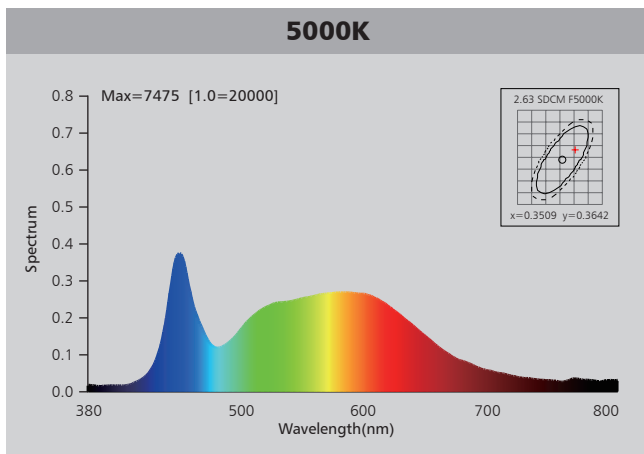
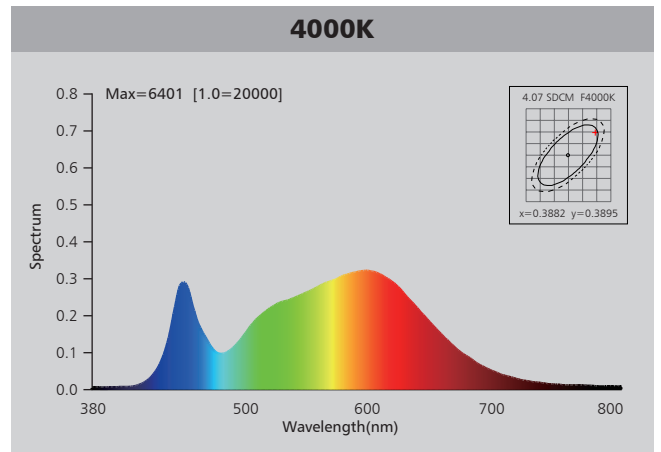
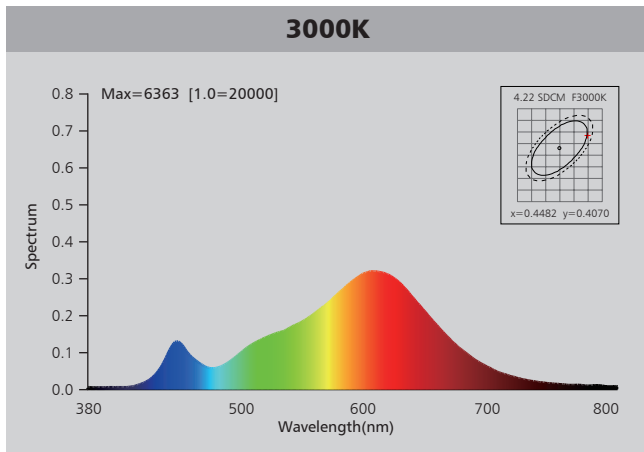

# Photometric Diagram

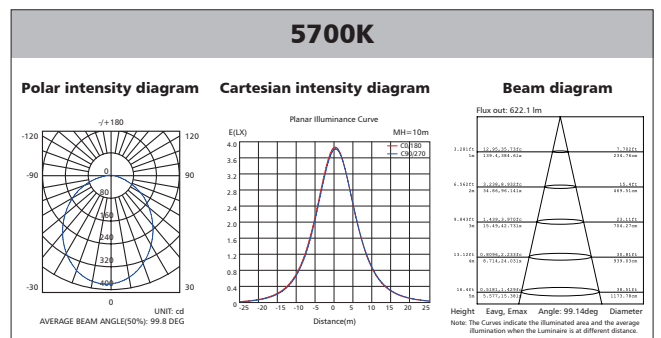
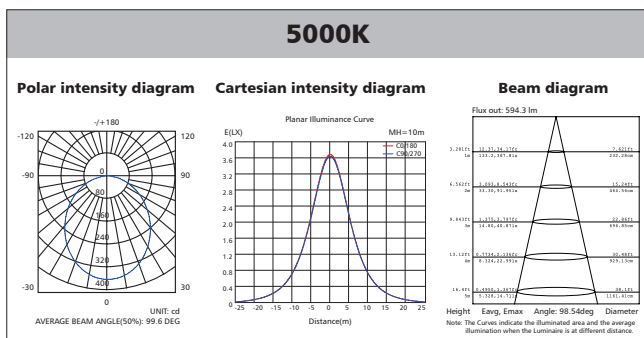
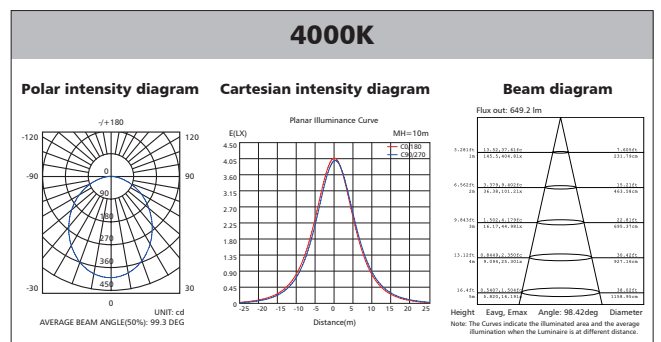
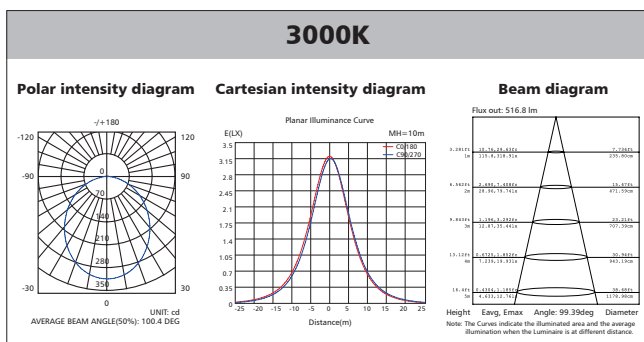

# Polar Diagram Comparison

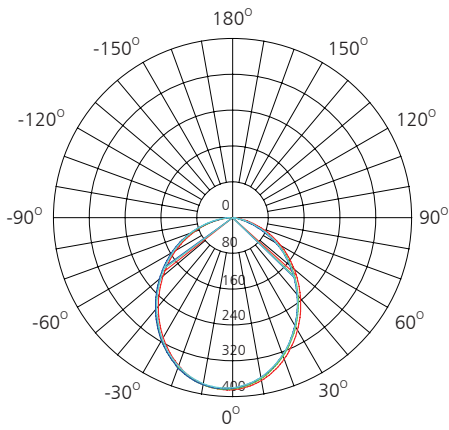

UNIT: cd

- C0/180, 99.7 deg
- C30/210, 99.8 deg
- C60/240, 99.8 deg
- C90/270, 99.7 deg

AVERAGE BEAM ANGLE (50%): 99.8DEG



# Driver lifetime & LED light decay rate

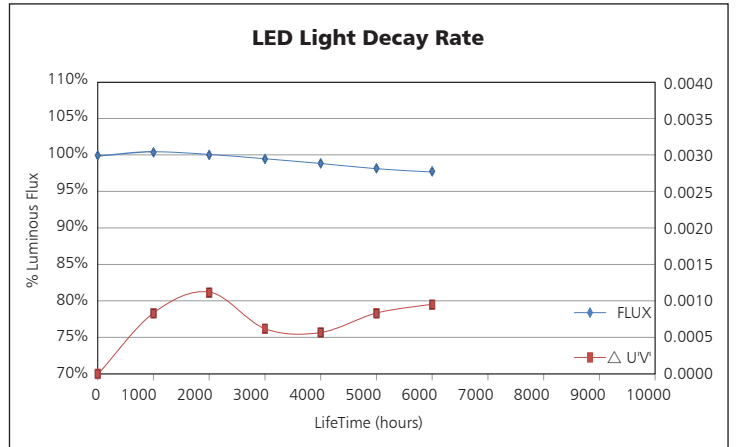
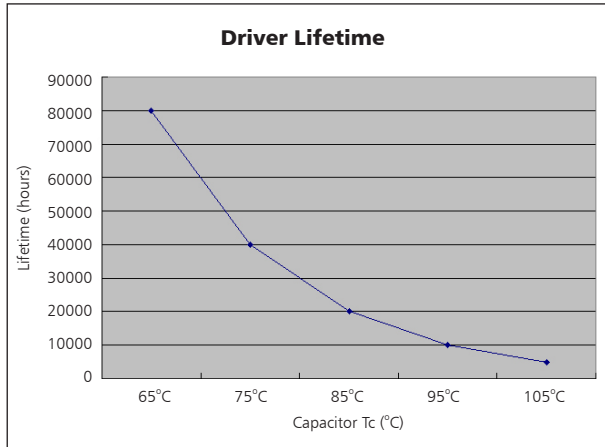

# Temperature

- The testing is operated at 25°C
- The lifetime of capacitor, minimum of 5,000 hours if operated at 105°C, will be doubled whenever the temperature drops 10°C
- The highest withstand temperature of IC, MOS could be 120°C
- The highest withstand temperature of LED junction temperature is 150°C

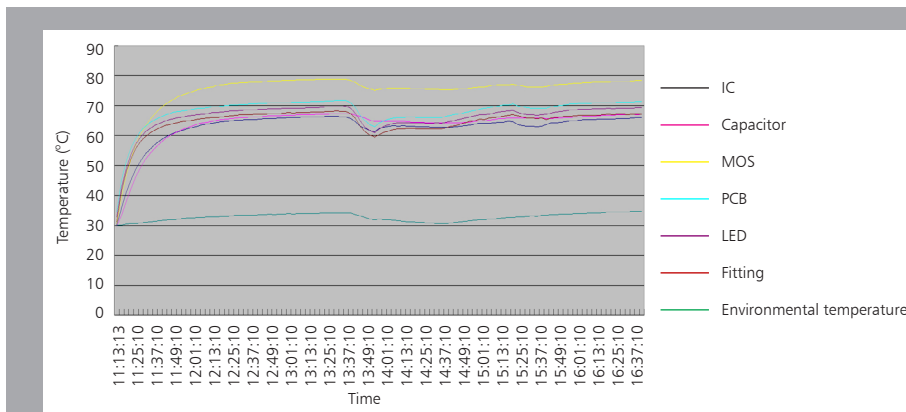

The driver lifespan is based on capacitor working temperature.

# Installation

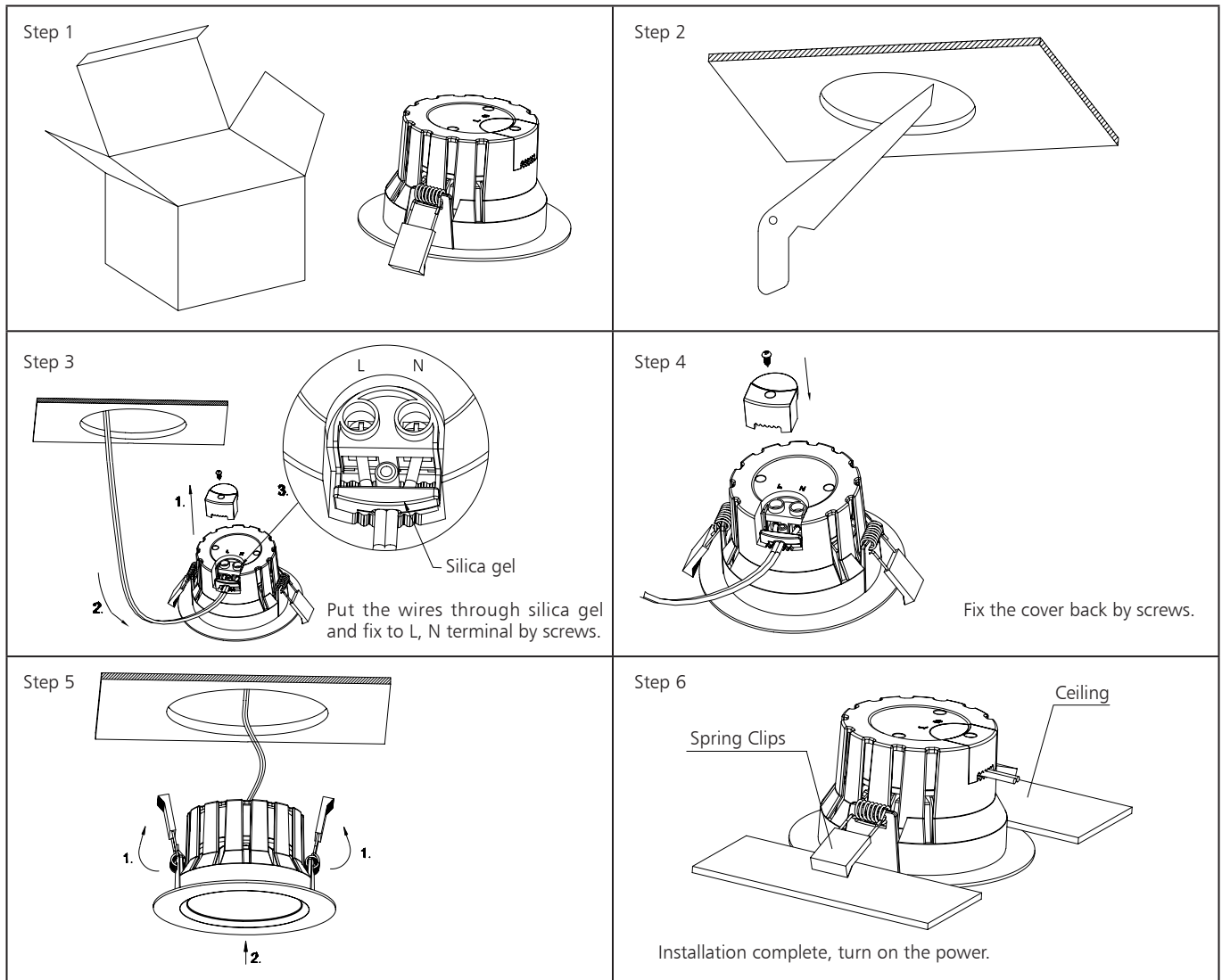

# Packaging Information

	SIZE(CM)	N.W/pc (KGS)	G.W.(KGS)	Q'TY(PCS)
Carton	52*39*32	0.21	13	48

	CTNS	Q'TY(PCS)	VOLUME(CBM)
20" standard container	424	20352	28
40" standard container	848	40704	56

