



Technical Application Guide For UP-SHINE Surface Mounted LED Downlight

UP-DL52-8W-D

Introduction



Up-shine surface mounted ceiling light adopts high lumen SMD LED, PMMA diffuser with even light output. IP54 waterproof structural design, it is an ideal replacement for damp location.

- Up to 70% energy saving compared to standard CFL
- Long lifetime of 40,000 hours
- Dimmable when using triac dimmer
- 100° wide beam angle
- CCT: 3000K 4000K
5000K 5700K
- No UV/IR light
- Environment friendly, without Mercury or any other hazardous substances

Application notes

- IP54 for indoor use only
- Professional electrician for installation only
- Switch off before installation
- Do not touch when in use
- Keep away from hot steam and corrosive gas

Application Areas

Up-shine downlight is designed for general lighting applications in hotel, home, office, shop etc. It is also widely used for public areas such as stairway, lobby, reception, corridors etc.

Certificate

CE RoHS



Product Information

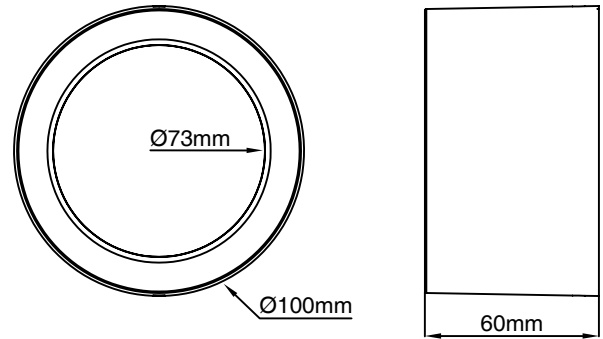

Technical Specifications

Model	Voltage	Power	Power Factor	Lumen (±5%)	Beam angle	CCT	Lifespan	CRI	Dimmable	Dimension
UP-DL52-8W-D	AC230V	8W	≥0.9	672	100°	3000K	40000h	≥80	Yes	Ø100*60mm
UP-DL52-8W-D	AC230V	8W	≥0.9	744	100°	4000K	40000h	≥80	Yes	Ø100*60mm
UP-DL52-8W-D	AC230V	8W	≥0.9	680	100°	5000K	40000h	≥80	Yes	Ø100*60mm
UP-DL52-8W-D	AC230V	8W	≥0.9	720	100°	5700K	40000h	≥80	Yes	Ø100*60mm

Driver data Sheet

Driver data	DIM
Input rated Voltage	AC230V
Frequency	50HZ
Input Voltage	AC200-240V
Efficiency	≥78%
Total load Wattage	8W±0.5W
Power Factor	≥0.9
Rated input current	≤0.04A
Full load output Voltage	60-75V
Rated output current	90mA
Output current range	90mA±5%
Power tolerance	±5%
Current output tolerance	±5%
Dimming range	8%-100%
Dimmer	Triac dimmers
Short circuit protection	PASS
Over voltage protection	PASS
Over temperature protection	PASS
Withstand voltage	AC3750V

Fixture Compatibility

Rated Wattage	Electrical Classification	Ingress Protection	Operating Temp	Operating Humidity	Storage Temp
8W	II	IP54	-20°C~45°C	0~90%	-20°C~65°C

Spectral Distribution

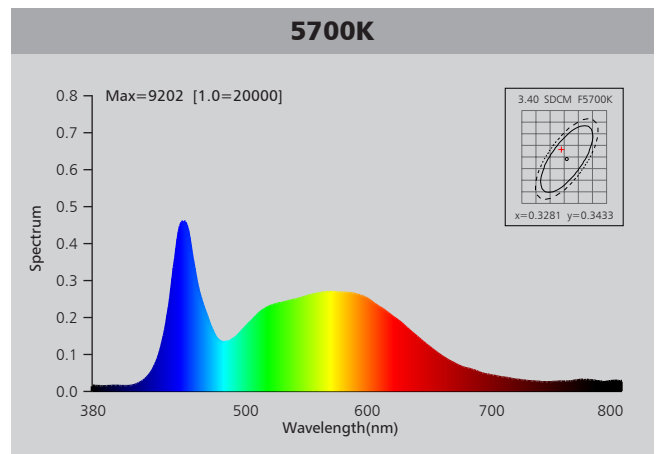
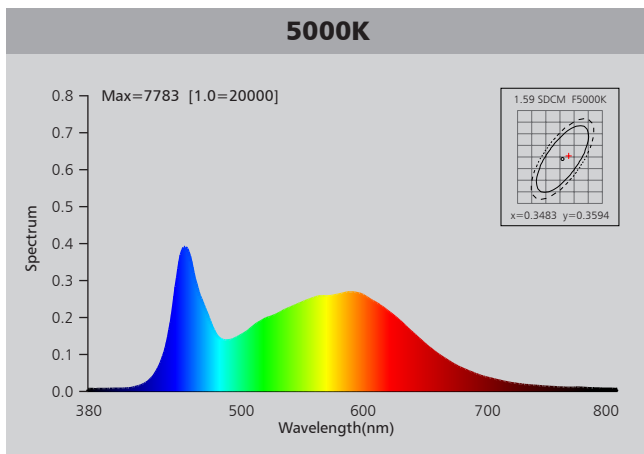
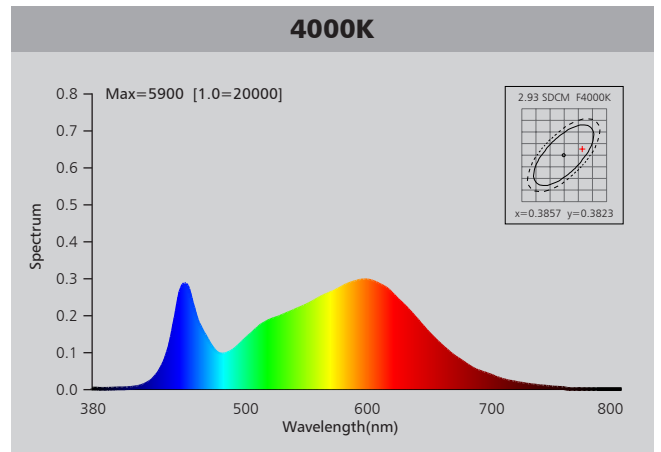
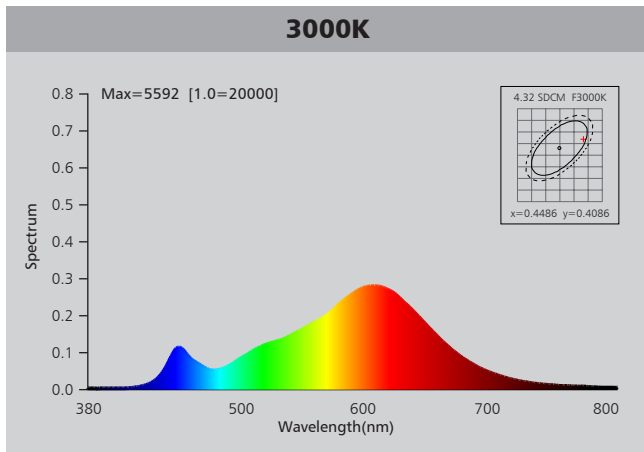

Photometric Diagram

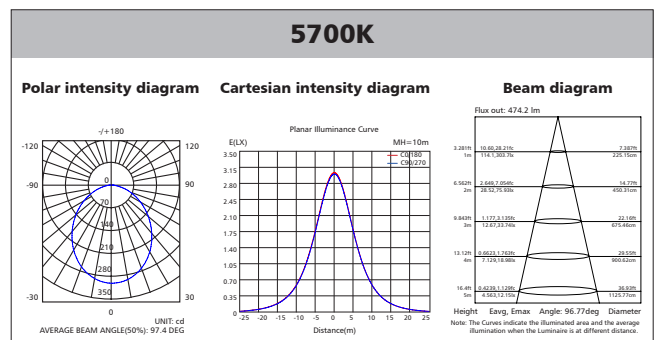
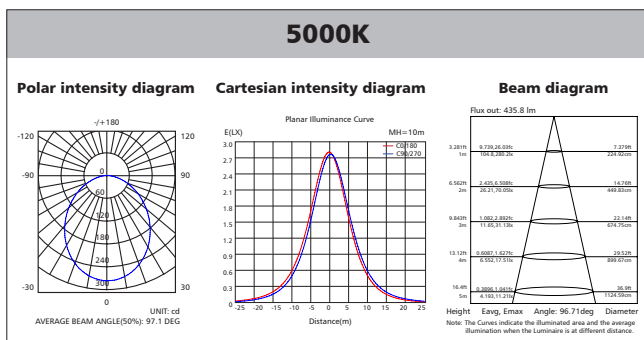
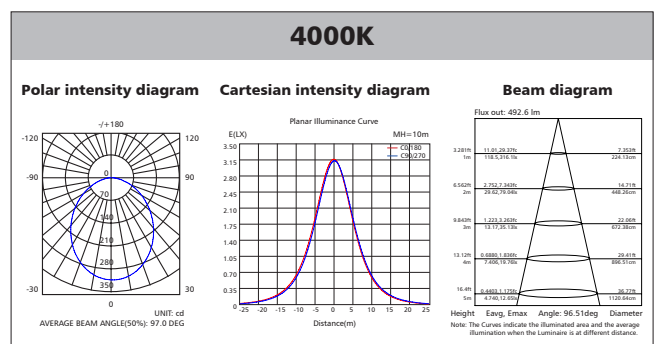
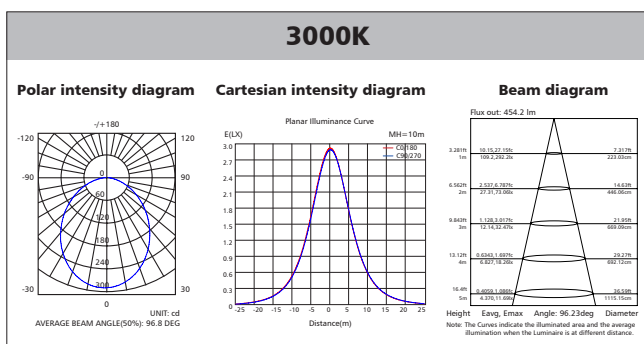

Polar Diagram Comparison

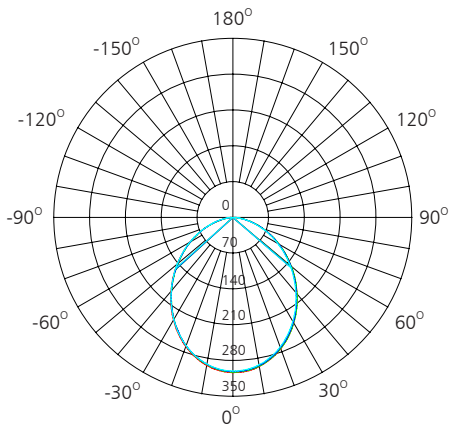

UNIT: cd

- C0/180, 97.4 deg
- C30/210, 97.4 deg
- C60/240, 97.4 deg
- C90/270, 97.4 deg



AVERAGE BEAM ANGLE (50%): 97.4DEG

Driver lifetime & LED light decay rate

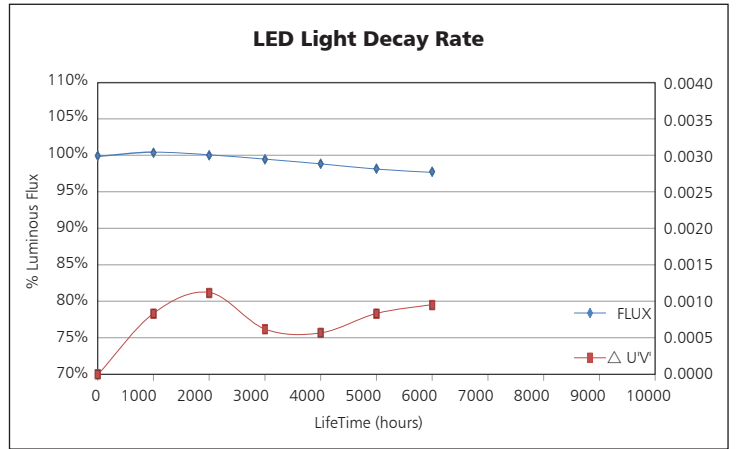
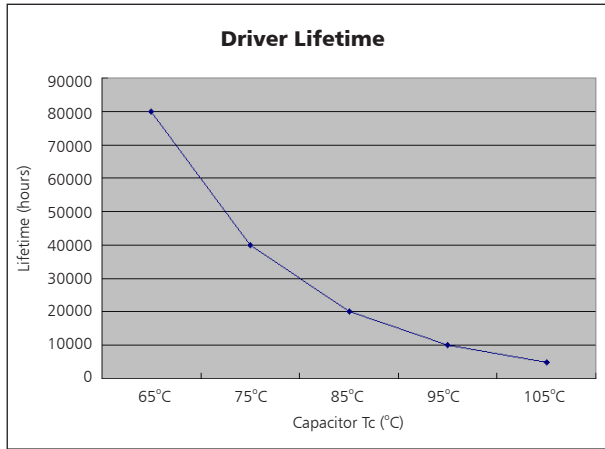

Temperature

- The testing is operated at 25°C
- The lifetime of capacitor, minimum of 5,000 hours if operated at 105°C, will be doubled whenever the temperature drops 10°C
- The highest withstand temperature of IC, MOS could be 120°C
- The highest withstand temperature of LED junction temperature is 150°C

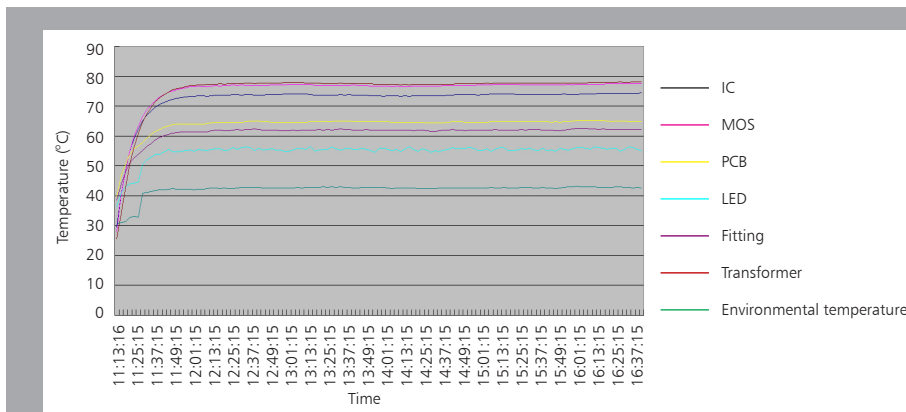

The driver lifespan is based on capacitor working temperature.

Installation

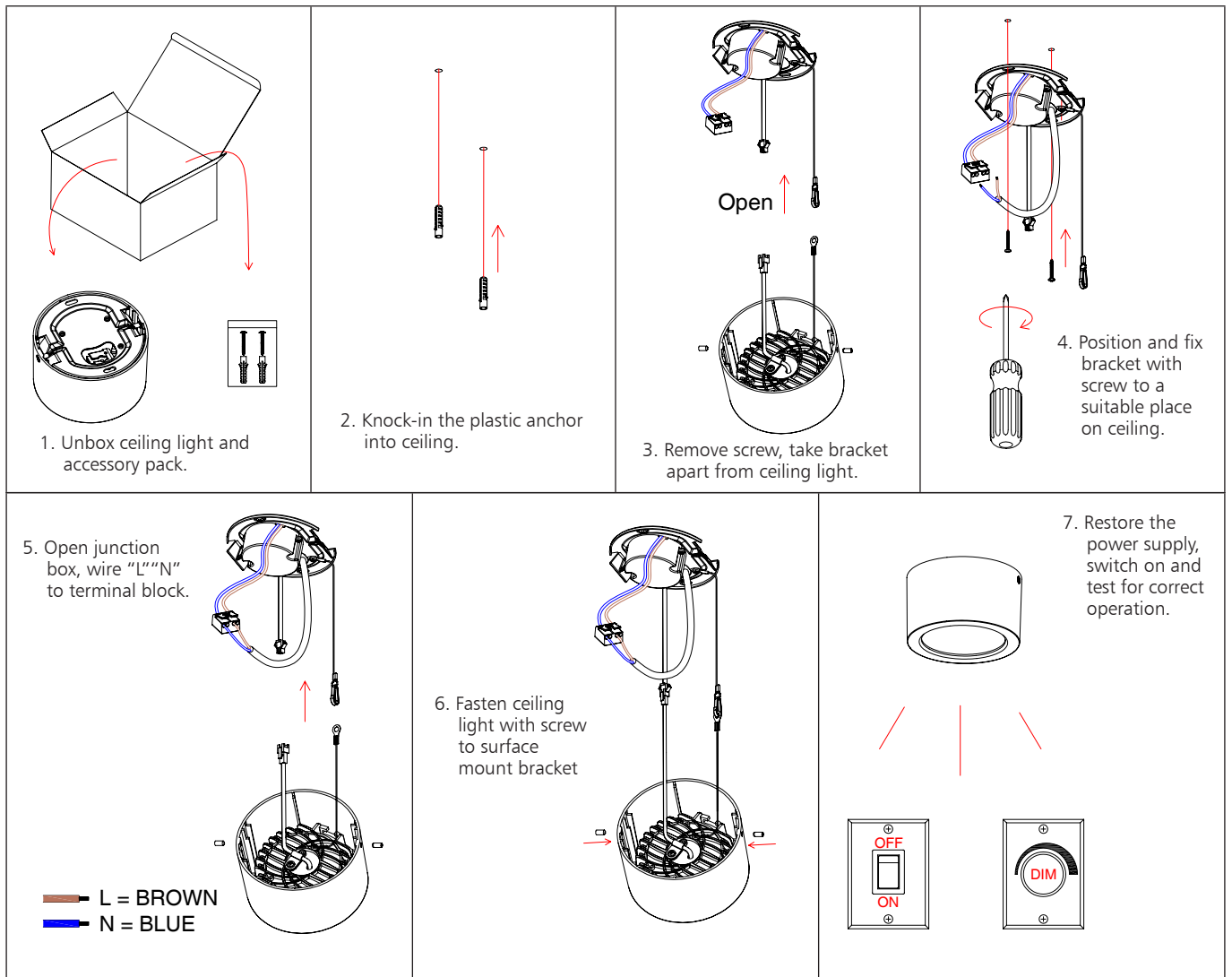

Packaging Information

	SIZE(CM)	N.W/pc (KGS)	G.W.(KGS)	Q'TY(PCS)	CTNS	Q'TY(PCS)	VOLUME(CBM)
Carton	67.5*41*19	0.35	11.3	30	20" standard container	522	15660
					40" standard container	1044	31320

