

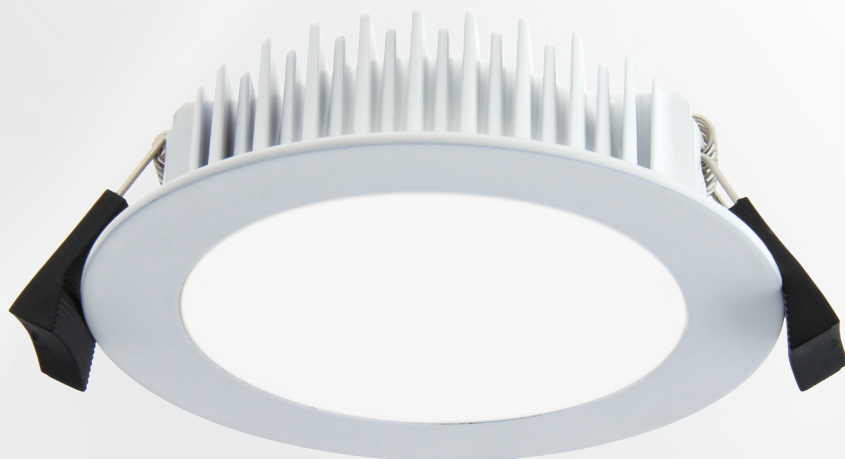

UPSHINE[®]

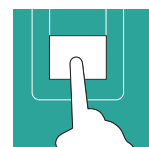

Technical Application Guide for Up-shine Color Changeable Dimmable LED Downlight

UP-DL44-3-13W-P



Introduction



Color changeable LED downlight adopts high lumen SMD LED. PMMA diffuser with even light output. The color is changeable from 2700K~5700K by dimming switch. Also dimmable with triac dimmers. Multi-functional design shares great popularity.

- Up to 70% energy saving compared to standard CFL
- Long lifetime of 40,000 hours
- 90° wide beam angle
- 90-95mm cutout
- No UV/IR light
- Environment friendly, without Mercury or any other hazardous substances

Application notes

- IP54 for indoor use only
- Professional electrician for installation only
- Switch off before installation
- Do not touch when in use
- Keep away from hot steam and corrosive gas

operation illustrate:

1. First switch on and switch off to initial color A
2. Second switch on and switch off to color B
3. Third switch on and switch off to color C
4. Fourth switch on and switch off go back to initial color A
5. Triac dimming is available once a color has been selected

Application Areas

It is designed for general lighting applications in office, supermarket, shop, school, hotel, etc. It is also widely used for public areas, such as stairway, lobby, reception, corridors etc.

Certificate

CE **RoHS** **SAA**

Product Information

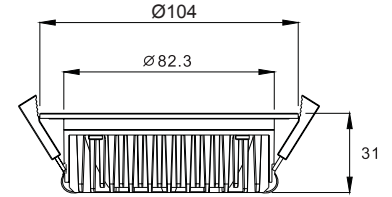

Technical Specifications

Model	Voltage	Power	Power Factor	Lumen (±5%)	Beam angle	CCT	Lifespan	CRI	Dimmable	Dimension
UP-DL44-3-13W-P	AC230V	13W	≥0.9	900	90°	2700K	40000h	≥80	Yes	Ø104*31mm cutout 90-95mm
UP-DL44-3-13W-P	AC230V	13W	≥0.9	1030	90°	4000K	40000h	≥80	Yes	Ø104*31mm cutout 90-95mm
UP-DL44-3-13W-P	AC230V	13W	≥0.9	920	90°	5700K	40000h	≥80	Yes	Ø104*31mm cutout 90-95mm

Driver data Sheet

Driver data	Dim
Input rated Voltage	AC230V
Frequency	50HZ
Input Voltage	AC200-240V
Efficiency	≥85%
Total load Wattage	13W±1W
Power Factor	≥0.9
Rated input current	≤0.07A
Full load output Voltage	DC35-40V
Rated output current	270mA
Output current range	270mA±5%
Power tolerance	±5%
Current output tolerance	±5%
Short circuit protection	PASS
Over voltage protection	PASS
Over temperature protection	PASS
Dimmer(Triac+Switch)	8-100%
Withstand voltage	AC3750V

Fixture Compatibility

Rated Wattage	Electrical Classification	Ingress Protection	Operating Temp	Operating Humidity	Storage Temp
13W	II	IP54	-20°C~45°C	0~90%	-20°C~65°C

Spectral Distribution

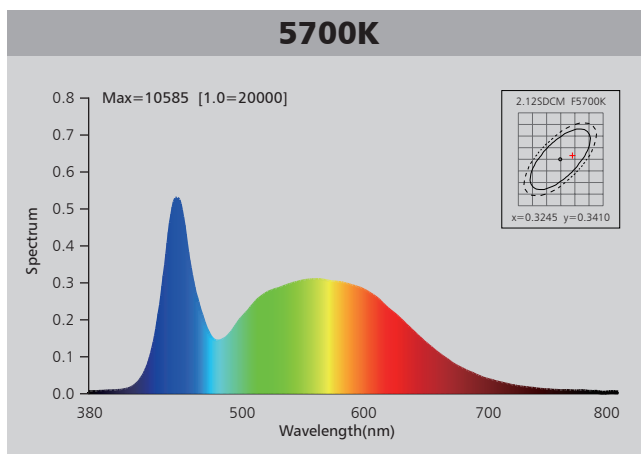
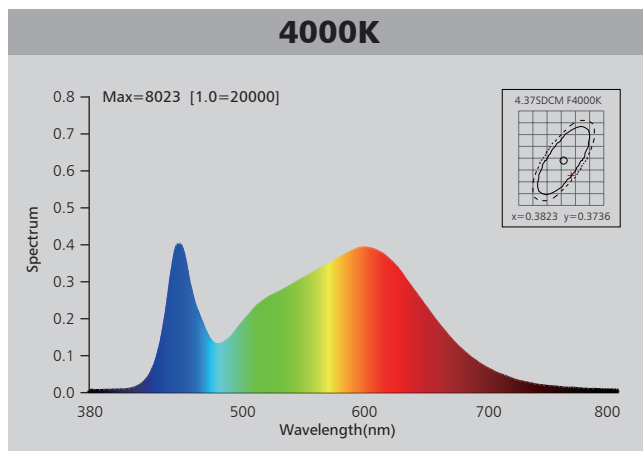
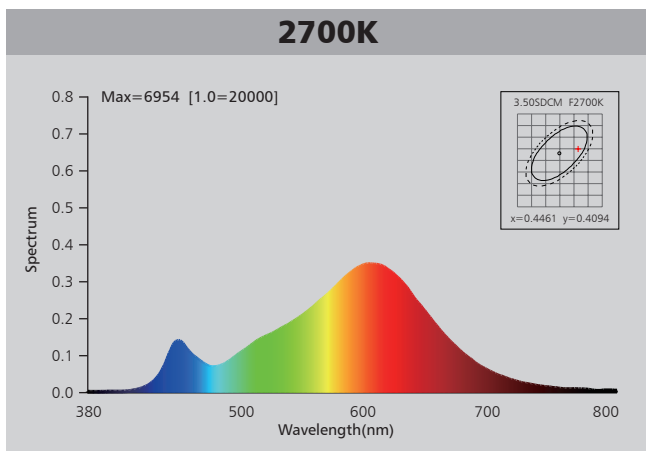

Photometric Diagram

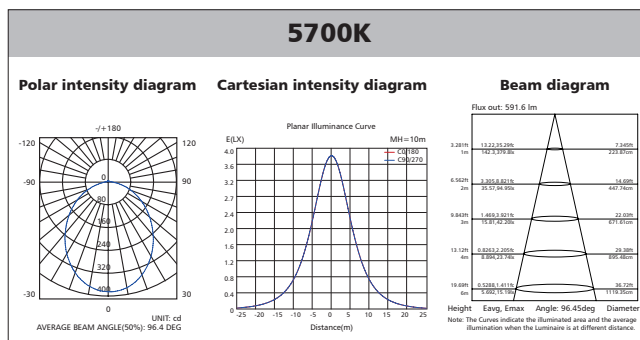
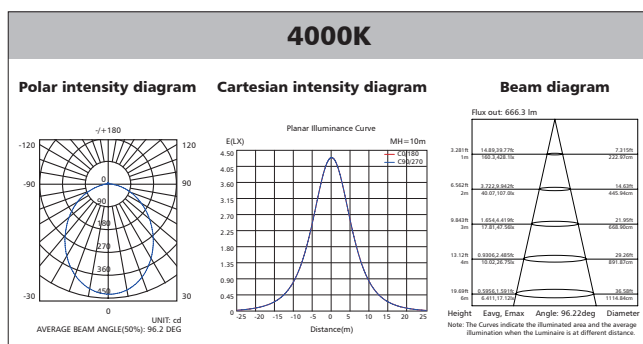
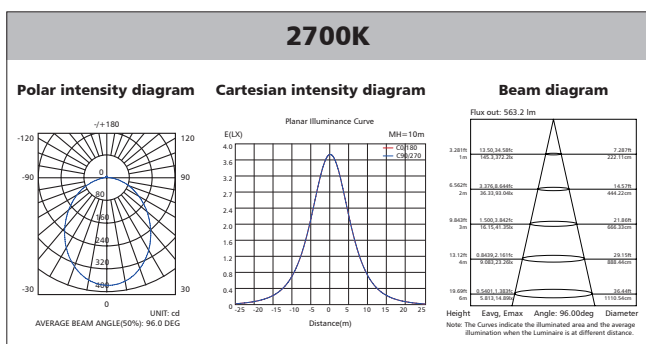

Polar Diagram Comparison

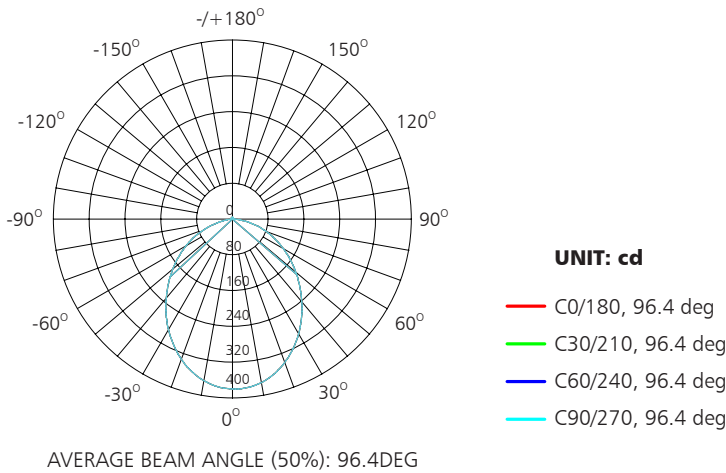

Driver lifetime & LED light decay rate

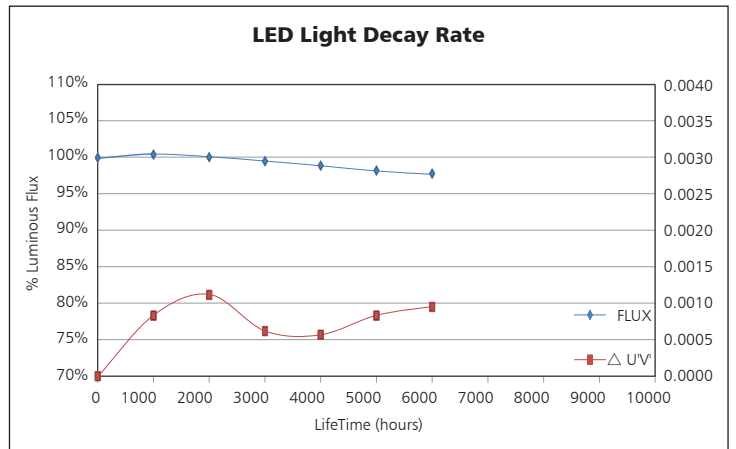
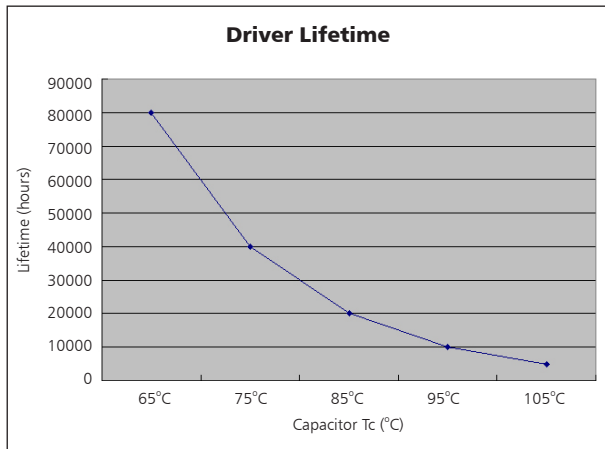

Temperature

- The testing is operated at 25°C
- The lifetime of capacitor, minimum of 5,000 hours if operated at 105°C, will be doubled whenever the temperature drops 10°C
- The highest withstand temperature of IC, MOS could be 120°C
- The highest withstand temperature of LED junction temperature is 150°C

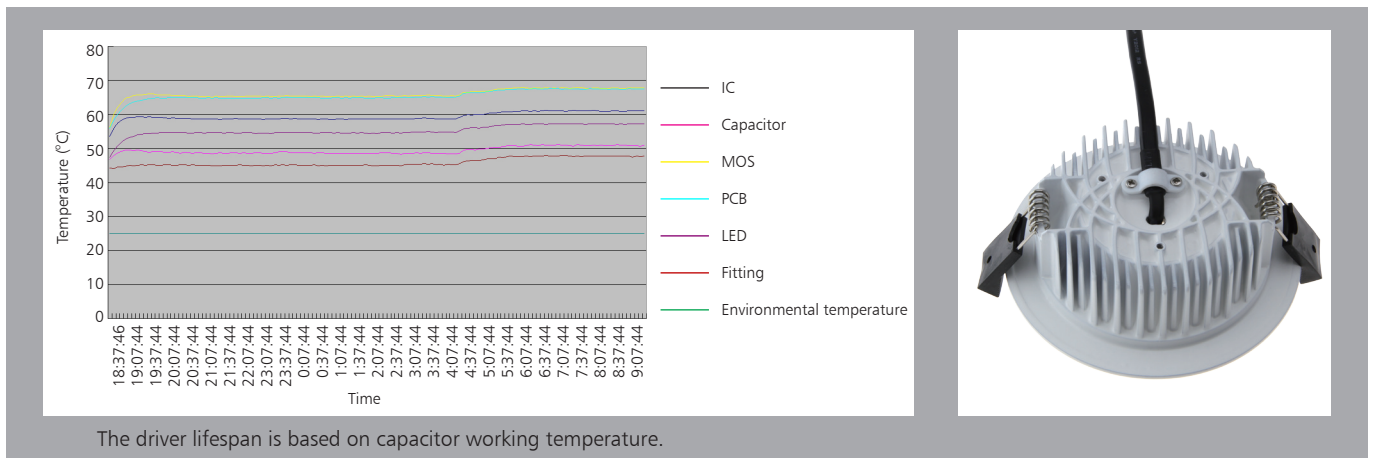

Installation

Install requirements	
A-gap above the fitting	25mm
B-gap to the building material	25mm
C-gap to the thermal insulation	25mm

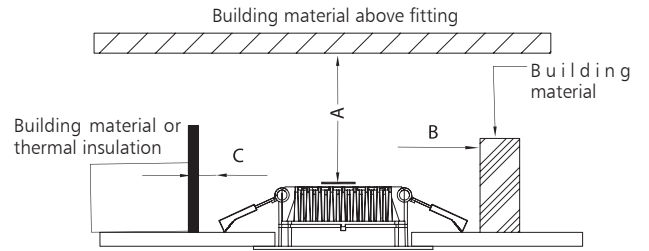

Ceiling Opening $\varnothing 90-95\text{mm}$

1

Connect Power supply

2

A. Hold back spring clips

B. Push downlight into position

3

Spring Clips

4

Packaging Information

	SIZE(CM)	N.W/pc (KGS)	G.W.(KGS)	Q'TY(PCS)
Carton	48.5 x 37 x 20	0.3	8.2	24

	CTNS	Q'TY(PCS)	VOLUME(CBM)
20" standard container	756	18144	28
40" standard container	1512	36288	56

