



Up-shine<sup>®</sup> Lighting



Technical Application  
Guide For UP-SHINE  
Surface Mounted  
LED Downlight  
UP-DL38-35W

# Introduction



DL38 surface mounted downlight adopts straightforward design with stylish appearance, easy to install. The lamp adopts high quality reflector which has good reflective rate and light output > 86%. AL6063 Aluminum body with oxidation treatment provides corrosion resistance and excellent heat dissipation performance. LEDs are high lumen COB chip with CRI>80. Built-in driver is independent and replaceable, which is friendly maintenance. PF>0.9, THD<20%, passed EMC test with strong anti-jamming capability. Besides, it possesses short-circuit protection and overvoltage protection function, showing high safety performance.

- Up to 70% energy saving compared to standard CFL
- Long lifetime of 40,000 hours
- Dimmable when using triac dimmer
- 24°/36°/45°/60° wide beam angle
- CCT: 2700K 3000K  
4000K 5000K
- No UV/IR light
- Environment friendly, without Mercury or any other hazardous substances

## Application notes

- IP54 for indoor use only
- Professional electrician for installation only
- Switch off before installation
- Do not touch when in use
- Keep away from hot steam and corrosive gas

## Application Areas

Up-shine 35W downlight is designed for general lighting applications in hotel, home, office, shop etc. It is also widely used for public areas such as stairway, lobby, reception, corridors etc.

## Certificate

CE RoHS

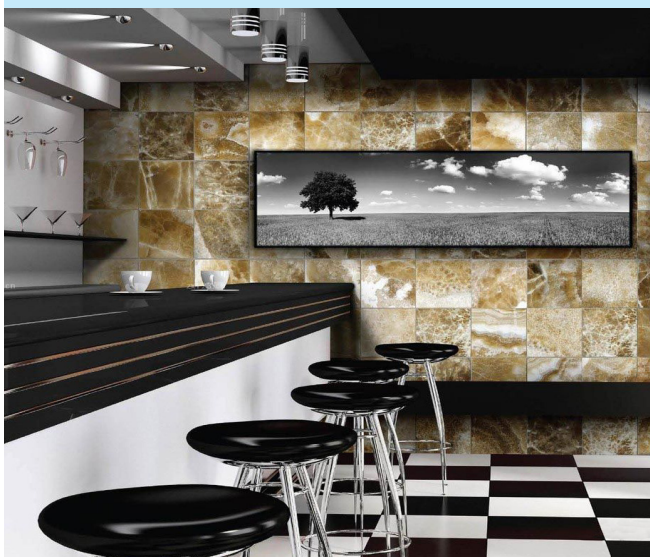

# Product Information

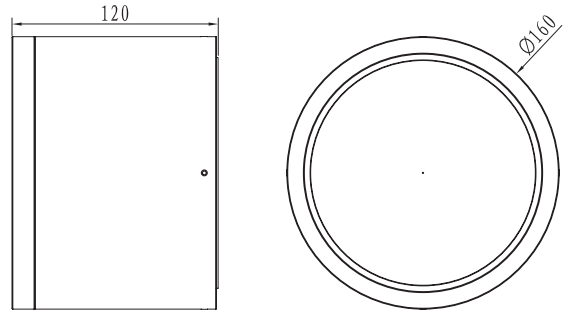

## Technical Specifications

Model	Voltage	Power	Power Factor	Lumen (±5%)	Beam angle	CCT	Lifespan	CRI	Dimmable	Dimension
UP-DL38-35W	AC100-240V	35W	≥0.9	3150	24°/36°/45°/60°	2700K	40000h	≥80	No	Ø160*120mm
UP-DL38-35W	AC100-240V	35W	≥0.9	3320	24°/36°/45°/60°	3000K	40000h	≥80	No	Ø160*120mm
UP-DL38-35W	AC100-240V	35W	≥0.9	3430	24°/36°/45°/60°	4000K	40000h	≥80	No	Ø160*120mm
UP-DL38-35W	AC100-240V	35W	≥0.9	3360	24°/36°/45°/60°	5000K	40000h	≥80	No	Ø160*120mm
UP-DL38-35W-D	AC230V	35W	≥0.9	3100	24°/36°/45°/60°	2700K	40000h	≥80	Yes	Ø160*120mm
UP-DL38-35W-D	AC230V	35W	≥0.9	3290	24°/36°/45°/60°	3000K	40000h	≥80	Yes	Ø160*120mm
UP-DL38-35W-D	AC230V	35W	≥0.9	3400	24°/36°/45°/60°	4000K	40000h	≥80	Yes	Ø160*120mm
UP-DL38-35W-D	AC230V	35W	≥0.9	3320	24°/36°/45°/60°	5000K	40000h	≥80	Yes	Ø160*120mm

## Driver data Sheet

Driver data	DIM	Non-dim
Input rated Voltage	AC230V	AC100-240V
Frequency	50HZ	50/60Hz
Input Voltage	AC200-240V	AC85-265V
Efficiency	≥83%	≥85%
Total load Wattage	35W±10%	35W±10%
Power Factor	≥0.9	≥0.9
Rated input current	0.2A	≤0.4A
Full load output Voltage	35-38V	35-38V
Rated output current	800mA	820mA
Output current range	800mA±5%	820mA±5%
Power tolerance	±5%	±5%
Current output tolerance	±5%	±5%
Dimming range	8%-100%	—
Dimmer	Triac dimmers	—
Short circuit protection	PASS	PASS
Over voltage protection	PASS	PASS
Over temperature protection	PASS	PASS
Withstand voltage	AC1500V	AC1500V

## Fixture Compatibility

Rated Wattage	Electrical Classification	Ingress Protection	Operating Temp	Operating Humidity	Storage Temp
35W	I	IP54	-20°C~45°C	0~90%	-20°C~65°C

# Spectral Distribution

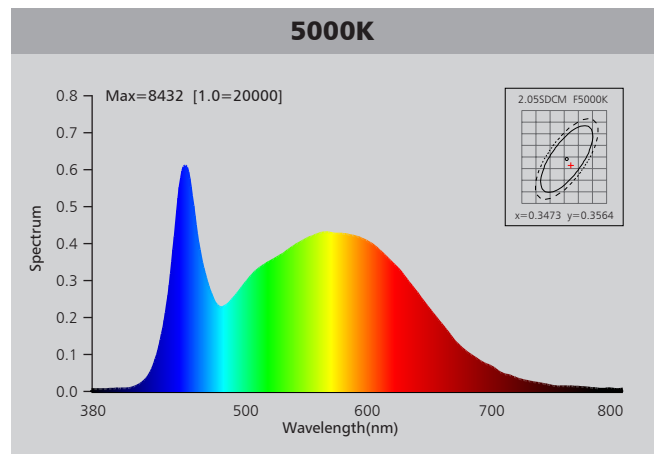
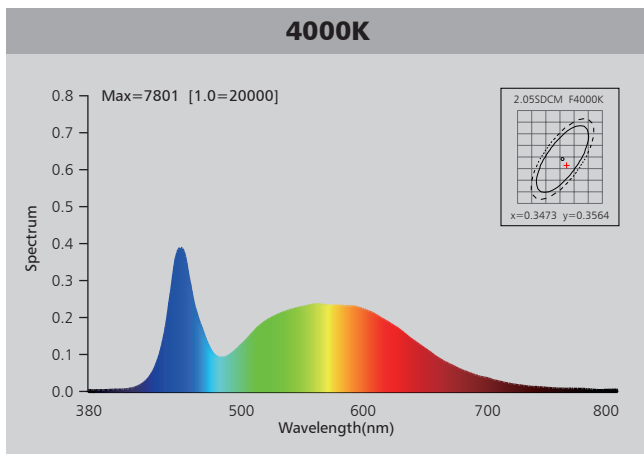
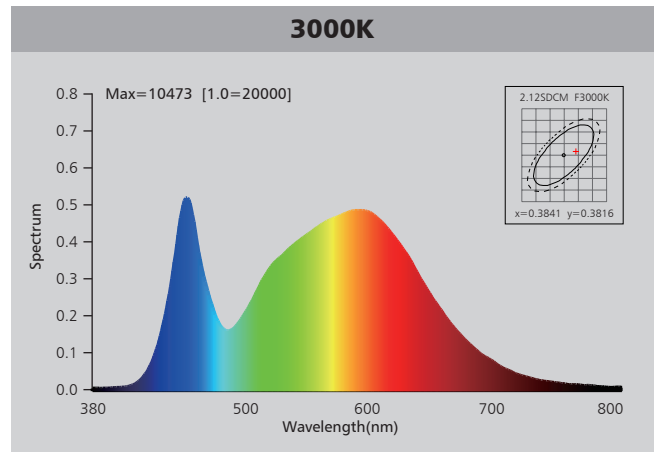
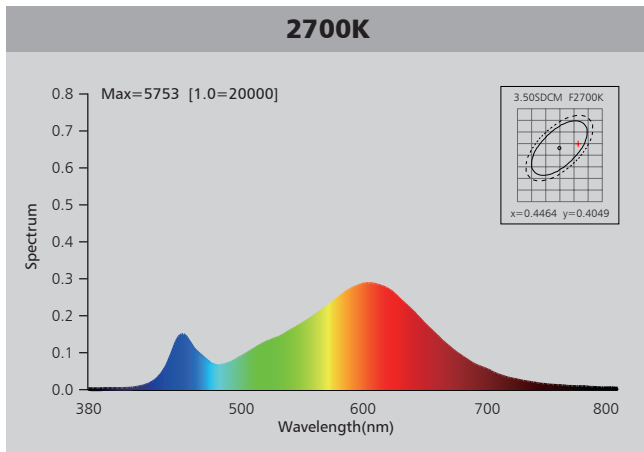

# Photometric Diagram

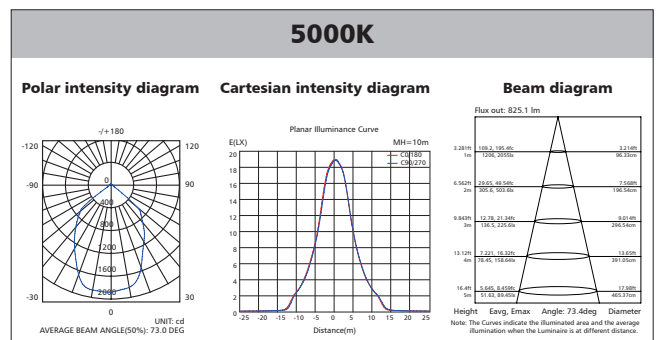
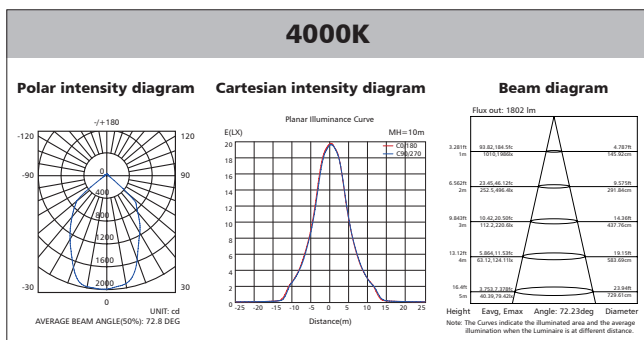
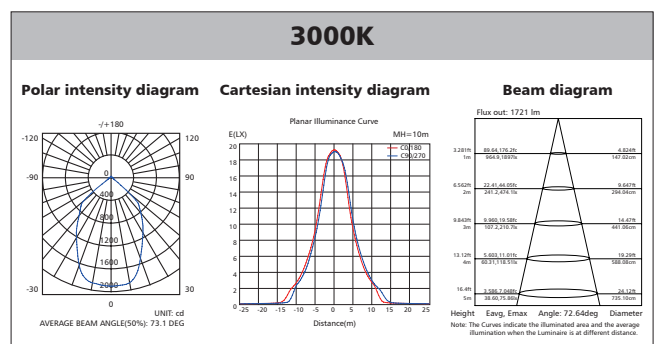
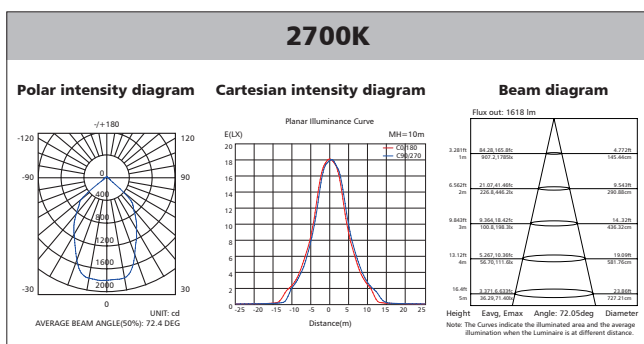

# Polar Diagram Comparison

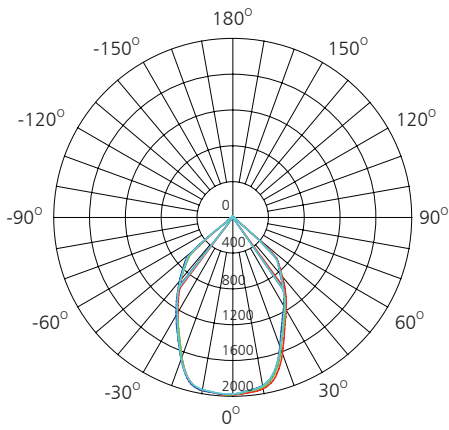

UNIT: cd

- C0/180, 72.9 deg
- C30/210, 72.8 deg
- C60/240, 72.9 deg
- C90/270, 72.6 deg



AVERAGE BEAM ANGLE (50%): 72.8DEG

# Driver lifetime & LED light decay rate

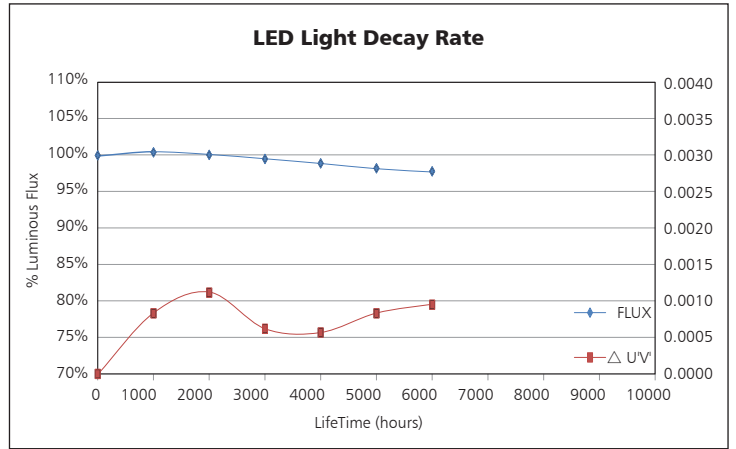
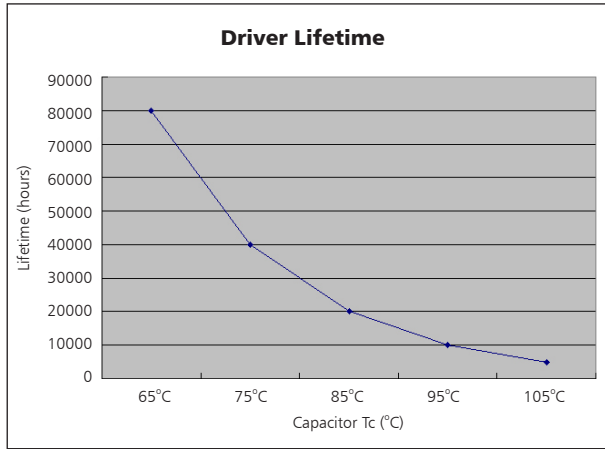

# Temperature

- The testing is operated at 25°C
- The lifetime of capacitor, minimum of 5,000 hours if operated at 105°C, will be doubled whenever the temperature drops 10°C
- The highest withstand temperature of IC, MOS could be 120°C
- The highest withstand temperature of LED junction temperature is 150°C

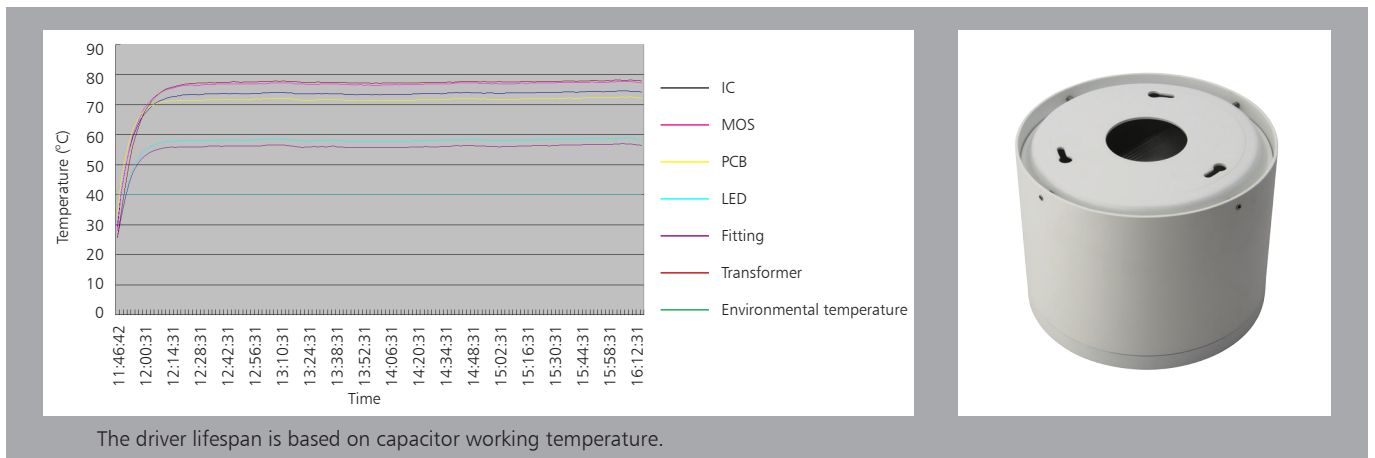

# Installation

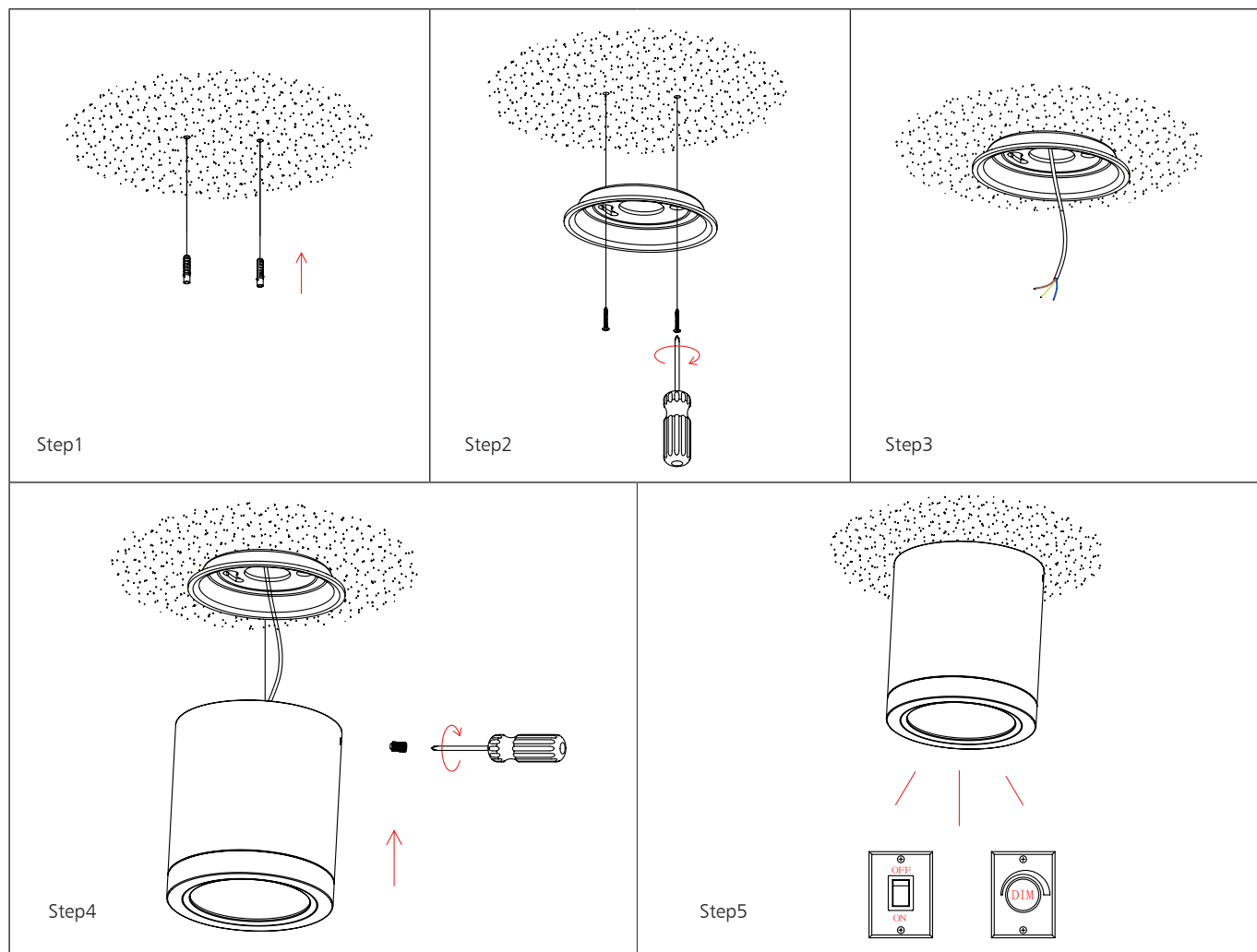

# Packaging Information

	SIZE(CM)	N.W/pc (KGS)	G.W.(KGS)	Q'TY(PCS)
Carton	42*42*51	1.3	17.5	12

	CTNS	Q'TY(PCS)	VOLUME(CBM)
20" standard container	307	3684	28
40" standard container	614	7368	56

