



Up-shine<sup>®</sup> Lighting



Technical Application  
Guide For UP-SHINE  
Surface Mounted  
LED Downlight  
UP-DL38-10W

# Introduction



DL38 surface mounted downlight adopts straightforward design with stylish appearance, easy to install. The lamp adopts high quality reflector which has good reflective rate and light output > 86%. AL6063 Aluminum body with oxidation treatment provides corrosion resistance and excellent heat dissipation performance. LEDs are high lumen COB chip with CRI>80. Built-in driver is independent and replaceable, which is friendly maintenance. PF>0.9, THD<20%, passed EMC test with strong anti-jamming capability. Besides, it possesses short-circuit protection and overvoltage protection function, showing high safety performance.

- Up to 70% energy saving compared to standard CFL
- Long lifetime of 40,000 hours
- Dimmable when using triac dimmer
- 60° wide beam angle
- CCT: 2700K 3000K  
4000K 5000K
- No UV/IR light
- Environment friendly, without Mercury or any other hazardous substances

## Application notes

- IP54 for indoor use only
- Professional electrician for installation only
- Switch off before installation
- Do not touch when in use
- Keep away from hot steam and corrosive gas

## Application Areas

Up-shine 10W downlight is designed for general lighting applications in hotel, home, office, shop etc. It is also widely used for public areas such as stairway, lobby, reception, corridors etc.

## Certificate

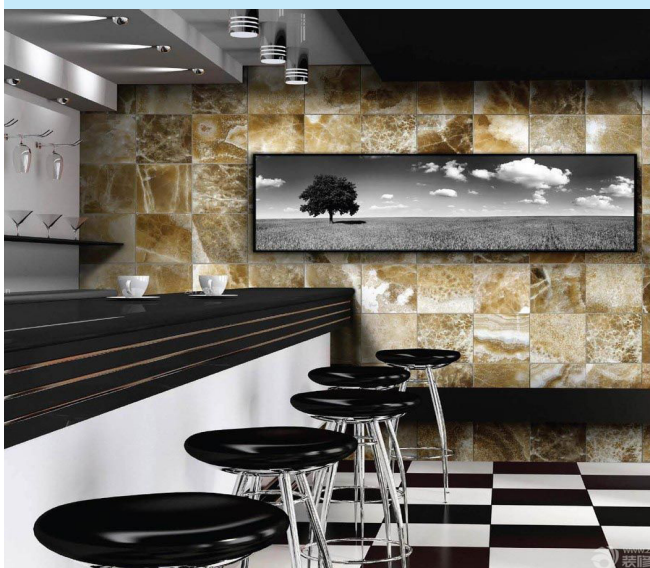

# Product Information

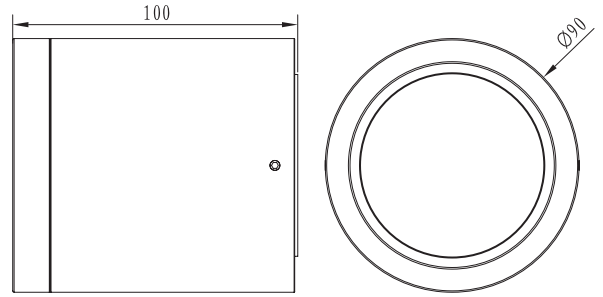

## Technical Specifications

Model	Voltage	Power	Power Factor	Lumen (±5%)	Beam angle	CCT	Lifespan	CRI	Dimmable	Dimension
UP-DL38-10W	AC100-240V	10W	≥0.9	660	60°	2700K	40000h	≥80	No	Ø90*100mm
UP-DL38-10W	AC100-240V	10W	≥0.9	730	60°	3000K	40000h	≥80	No	Ø90*100mm
UP-DL38-10W	AC100-240V	10W	≥0.9	780	60°	4000K	40000h	≥80	No	Ø90*100mm
UP-DL38-10W	AC100-240V	10W	≥0.9	740	60°	5000K	40000h	≥80	No	Ø90*100mm
UP-DL38-10W-D	AC230V	10W	≥0.9	620	60°	2700K	40000h	≥80	Yes	Ø90*100mm
UP-DL38-10W-D	AC230V	10W	≥0.9	690	60°	3000K	40000h	≥80	Yes	Ø90*100mm
UP-DL38-10W-D	AC230V	10W	≥0.9	740	60°	4000K	40000h	≥80	Yes	Ø90*100mm
UP-DL38-10W-D	AC230V	10W	≥0.9	700	60°	5000K	40000h	≥80	Yes	Ø90*100mm

## Driver data Sheet

Driver data	DIM	Non-dim
Input rated Voltage	AC230V	AC100-240V
Frequency	50HZ	50/60Hz
Input Voltage	AC200-240V	AC85-265V
Efficiency	≥78%	≥85%
Total load Wattage	10W±1W	10W±5%
Power Factor	≥0.9	≥0.9
Rated input current	0.06A	≤0.12A
Full load output Voltage	35-38V	35-38V
Rated output current	215mA	240mA
Output current range	215mA±5%	240mA±5%
Power tolerance	±5%	±5%
Current output tolerance	±5%	±5%
Dimming range	8%-100%	—
Dimmer	Triac dimmers	—
Short circuit protection	PASS	PASS
Over voltage protection	PASS	PASS
Over temperature protection	PASS	PASS
Withstand voltage	AC1500V	AC1500V

## Fixture Compatibility

Rated Wattage	Electrical Classification	Ingress Protection	Operating Temp	Operating Humidity	Storage Temp
10W	I	IP54	-20°C~45°C	0~90%	-20°C~65°C

# Spectral Distribution

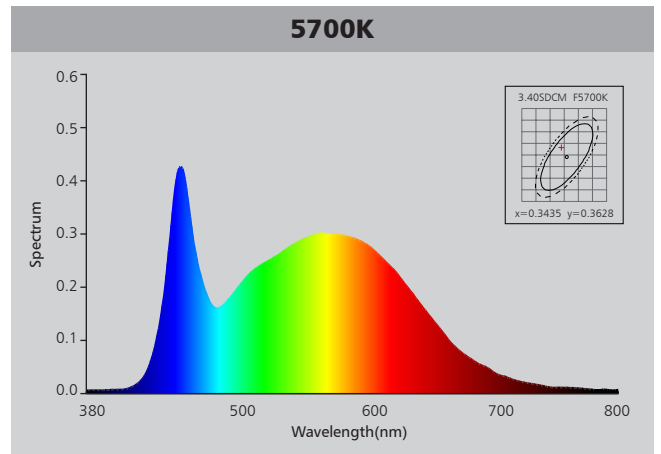
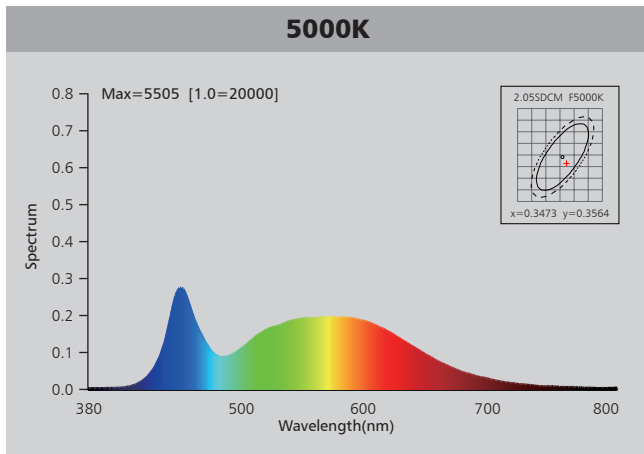
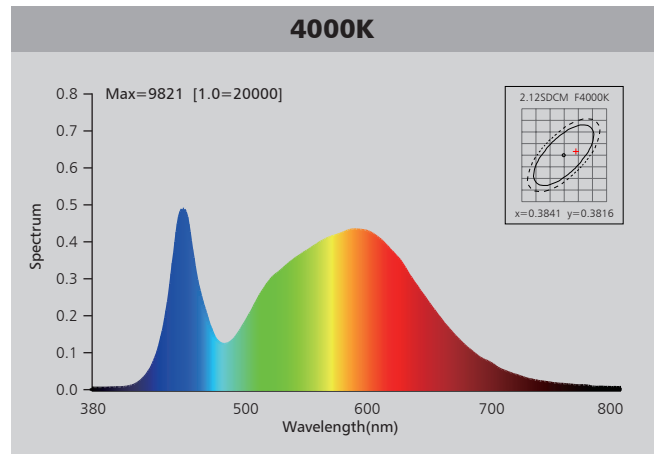
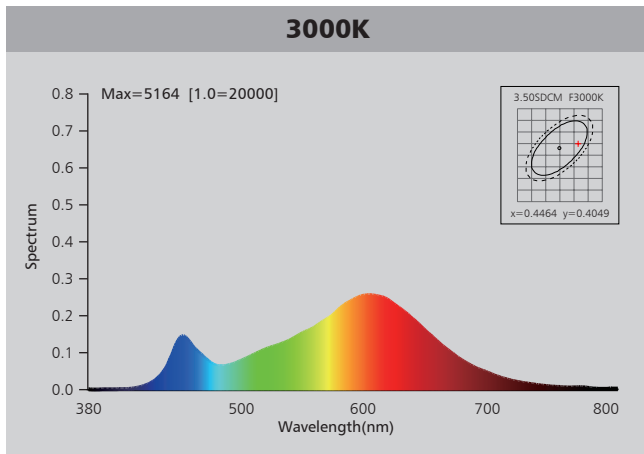

# Photometric Diagram

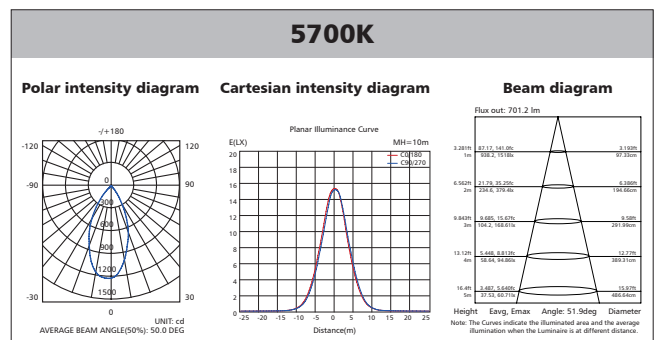
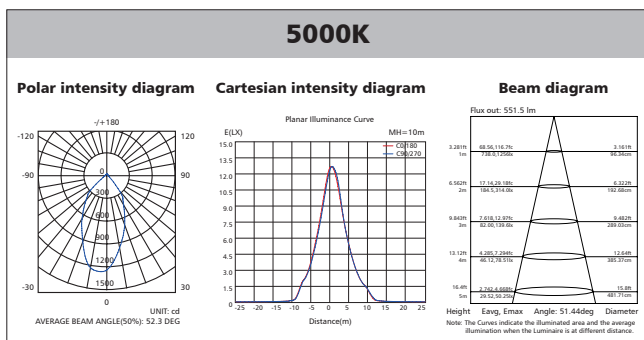
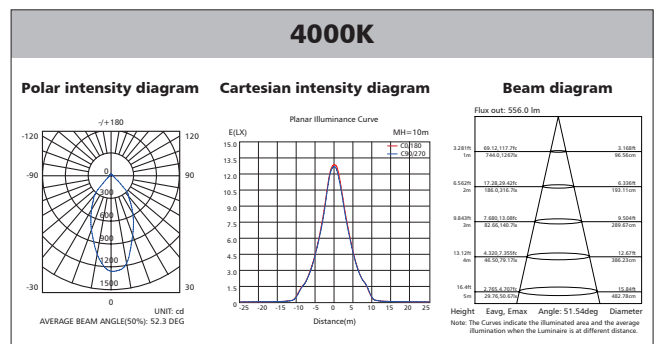
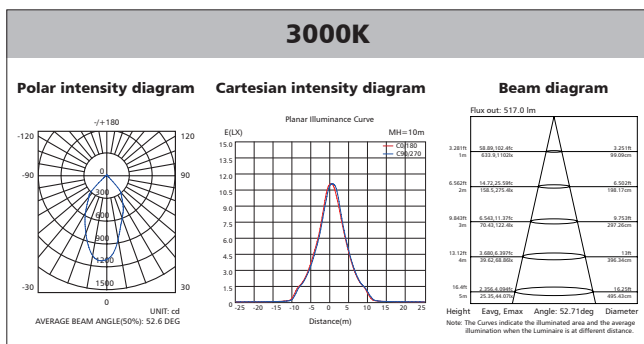

# Polar Diagram Comparison

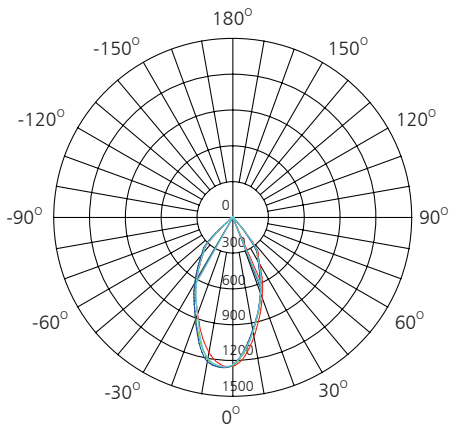

UNIT: cd

- C0/180, 53.0 deg
- C30/210, 52.7 deg
- C60/240, 51.9 deg
- C90/270, 51.4 deg



AVERAGE BEAM ANGLE (50%): 52.3DEG

# Driver lifetime & LED light decay rate

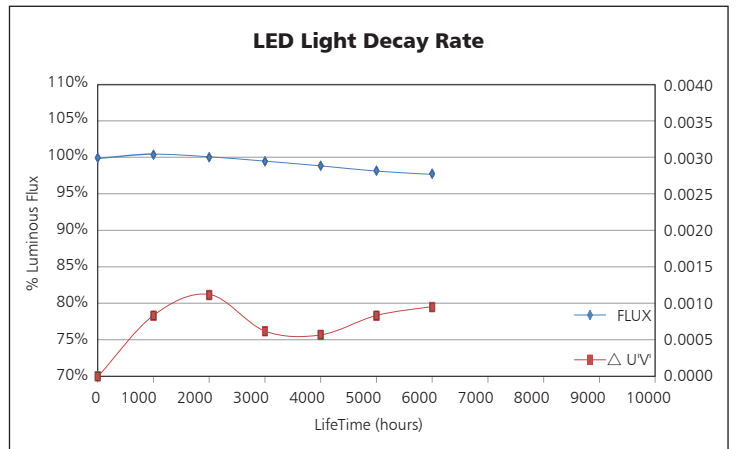
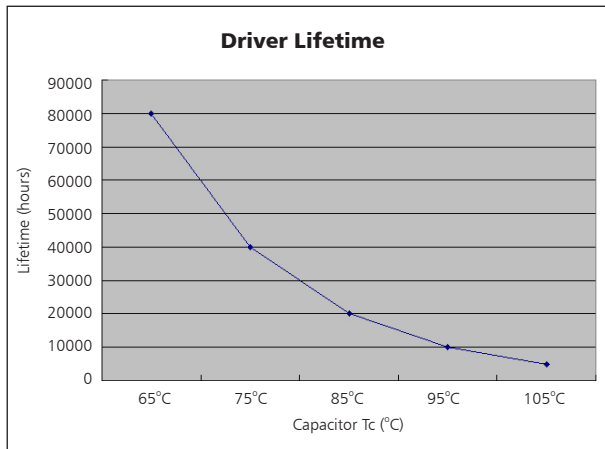

# Temperature

- The testing is operated at 25°C
- The lifetime of capacitor, minimum of 5,000 hours if operated at 105°C, will be doubled whenever the temperature drops 10°C
- The highest withstand temperature of IC, MOS could be 120°C
- The highest withstand temperature of LED junction temperature is 150°C

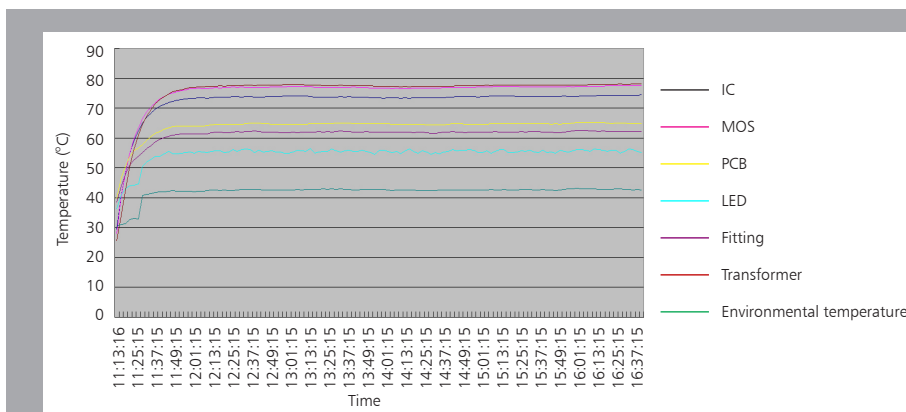

The driver lifespan is based on capacitor working temperature.

# Installation

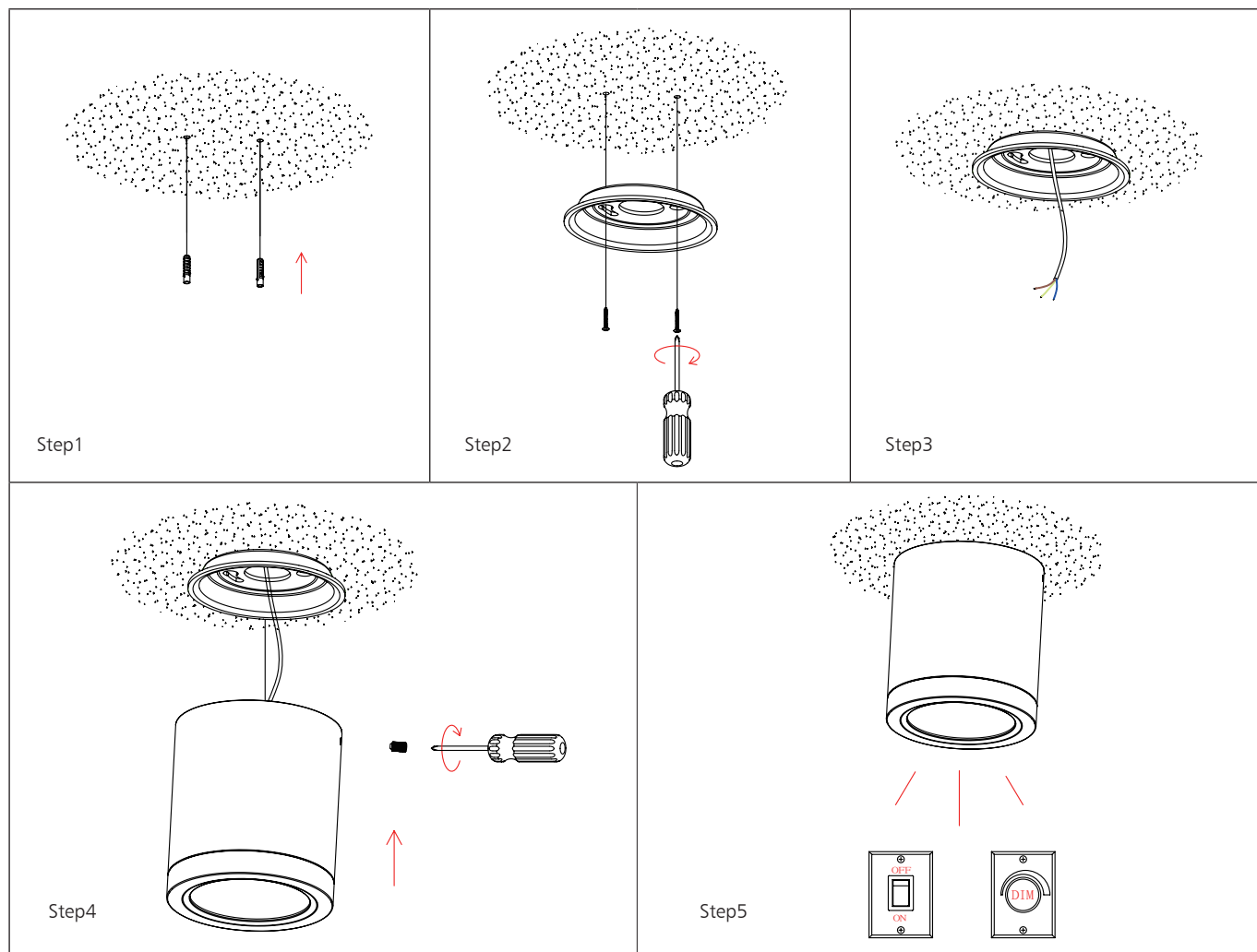

# Packaging Information

	SIZE(CM)	N.W/pc (KGS)	G.W.(KGS)	Q'TY(PCS)
Carton	50*38*29	0.52	14.5	24

	CTNS	Q'TY(PCS)	VOLUME(CBM)
20" standard container	499	11976	28
40" standard container	998	23952	56

