



UPSHINE®



Technical Application  
Guide for UP-SHINE  
LED Downlight  
UP-DL22-8-45W

# Introduction



Up-shine COB downlight is unique designed with reflector and Citizen COB high power LED chip. ADC12 Aluminum profile provides excellent thermal dissipation. Short heatsink designed for any ceiling installations. Isolated driver solution both in dimmable and non-dimmable version achieves great dimming compatibility with worldwide brand dimmers.

- Up to 70% energy saving compared to standard CFL
- Long lifetime of 40,000 hours
- Triac dim, 0-10V dim, DALI dim
- 24°/36°/60° wide beam angle
- 200-210mm cutout
- CCT: 2700K 3000K  
4000K 5000K
- No UV/IR light
- Environment friendly, without Mercury or any other hazardous substances

## Application notes

- IP20/IP44 for indoor use only
- Professional electrician for installation only
- Switch off before installation
- Do not touch when in use
- Keep away from hot steam and corrosive gas

## Application Areas

It is designed for general lighting applications in office, supermarket, shop, school, hotel, etc. It is also widely used for public areas, such as stairway, lobby, reception, corridors etc.

## Certificate

CE RoHS SAA



# Product Information

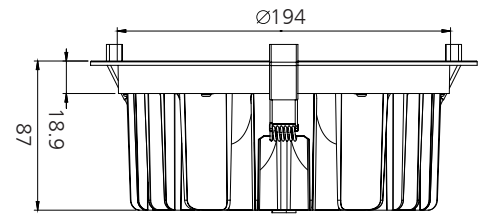
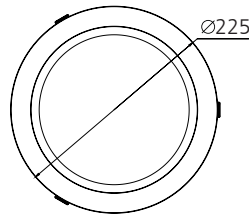

## Technical Specifications

Model	Voltage	Power	Power Factor	Lumen (±5%)	Beam angle	CCT	Lifespan	CRI	Dimmable	Dimension
UP-DL22-8-45W	AC230V	45W	≥0.9	4050	24°/36°/60°	2700K	40000h	≥80	No	Ø225*87mm cutout 200-210mm
UP-DL22-8-45W	AC230V	45W	≥0.9	4410	24°/36°/60°	3000K	40000h	≥80	No	Ø225*87mm cutout 200-210mm
UP-DL22-8-45W	AC230V	45W	≥0.9	4725	24°/36°/60°	4000K	40000h	≥80	No	Ø225*87mm cutout 200-210mm
UP-DL22-8-45W	AC230V	45W	≥0.9	4770	24°/36°/60°	5000K	40000h	≥80	No	Ø225*87mm cutout 200-210mm
UP-DL22-8-45W-D	AC230V	45W	≥0.9	3870	24°/36°/60°	2700K	40000h	≥80	Yes	Ø225*87mm cutout 200-210mm
UP-DL22-8-45W-D	AC230V	45W	≥0.9	4185	24°/36°/60°	3000K	40000h	≥80	Yes	Ø225*87mm cutout 200-210mm
UP-DL22-8-45W-D	AC230V	45W	≥0.9	4500	24°/36°/60°	4000K	40000h	≥80	Yes	Ø225*87mm cutout 200-210mm
UP-DL22-8-45W-D	AC230V	45W	≥0.9	4545	24°/36°/60°	5000K	40000h	≥80	Yes	Ø225*87mm cutout 200-210mm

## Driver data Sheet

Driver data	DIM	Non dim
Input rated Voltage	AC230V	AC230V
Frequency	50Hz	50/60Hz
Input Voltage	AC200-240V	AC200-240V
Efficiency	≥82%	≥87%
Total load Wattage	45W±5%	45W±5%
Power Factor	≥0.9	≥0.9
Rated input current	≤0.25A	≤0.25A
Full load output Voltage	DC28-40V	DC27-40V
Rated output current	1050mA	1050mA
Output current range	1050mA±5%	1050mA±5%
Power tolerance	±5%	±5%
Current output tolerance	±5%	±5%
Dimming range	8%-100%	—
Dimmer	Triac dimmers	—
THD	—	<18%
Short circuit protection	PASS	PASS
Over voltage protection	PASS	PASS
Over temperature protection	PASS	PASS
Withstand voltage	AC3750V	AC3750V

## Fixture Compatibility

Rated Wattage	Electrical Classification	Ingress Protection	Operating Temp	Operating Humidity	Storage Temp
45W	II	IP20/IP44	-20°C~45°C	0~90%	-20°C~65°C

# Spectral Distribution

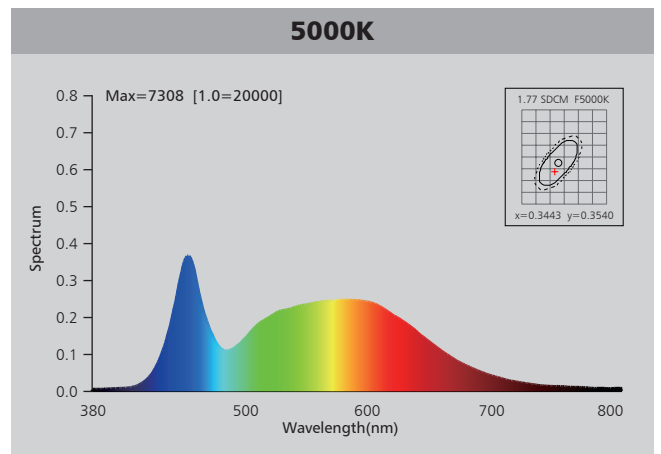
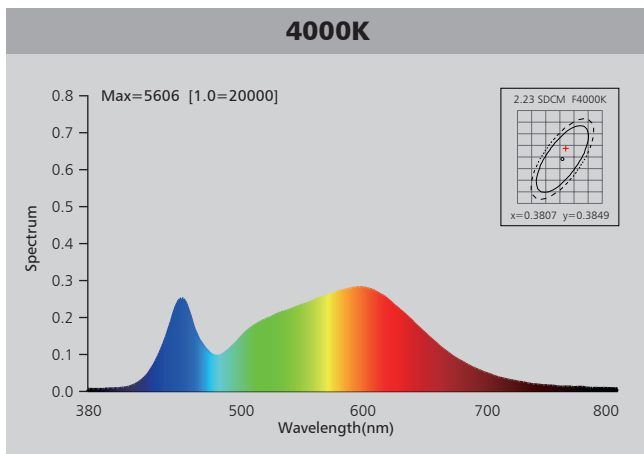
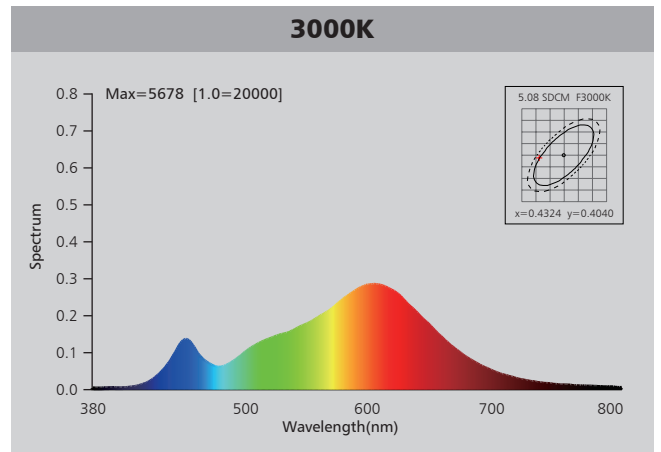
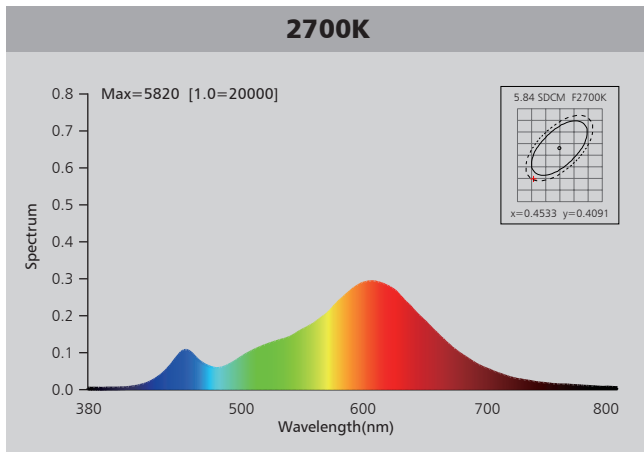

# Photometric Diagram

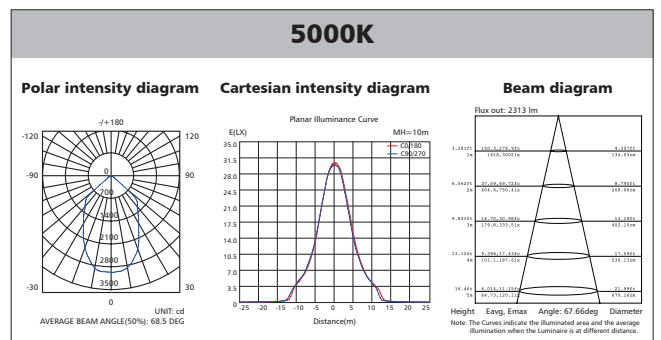
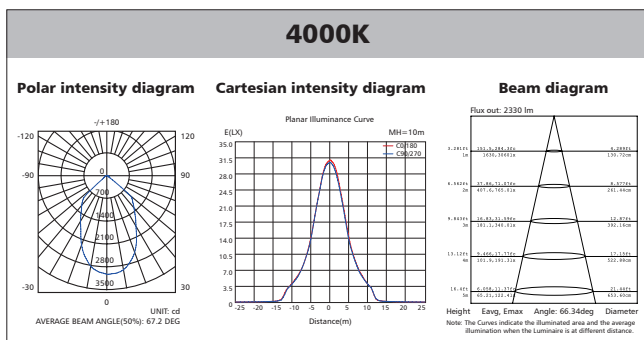
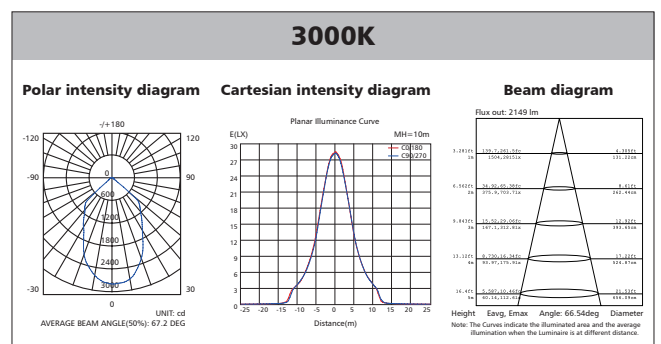
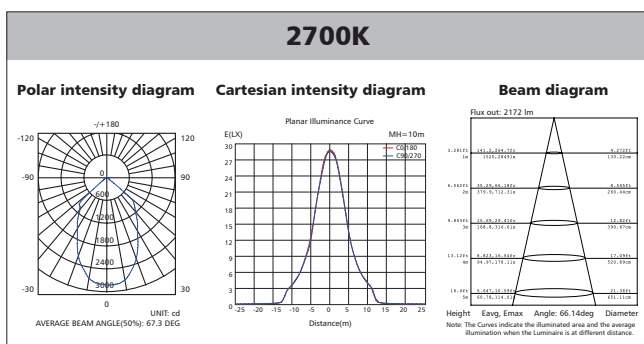

## Polar Diagram Comparison

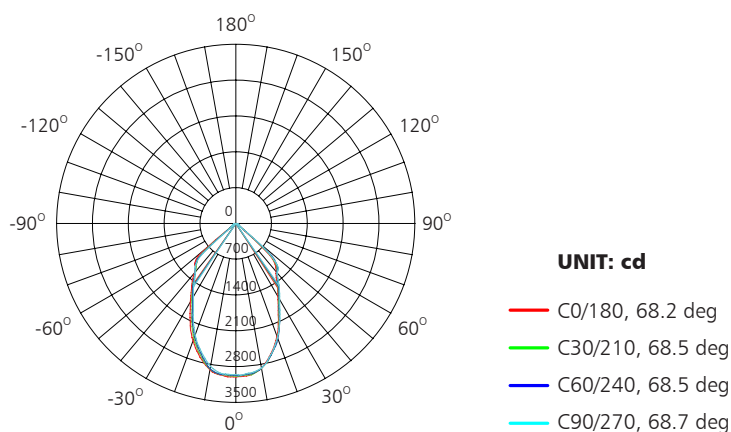

AVERAGE BEAM ANGLE (50%): 68.5DEG



## Driver lifetime & LED light decay rate

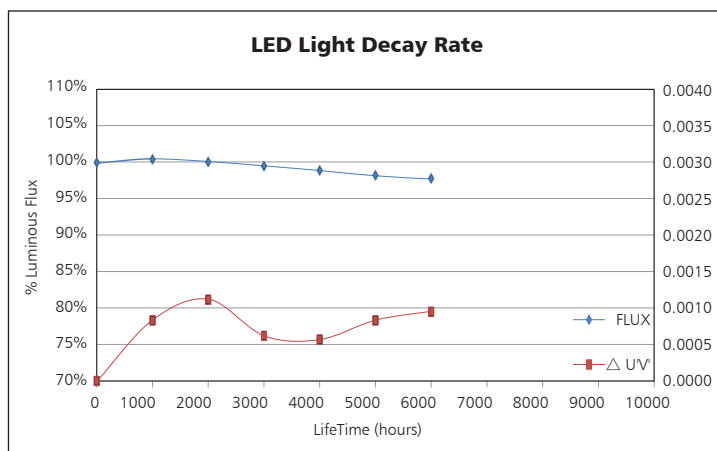
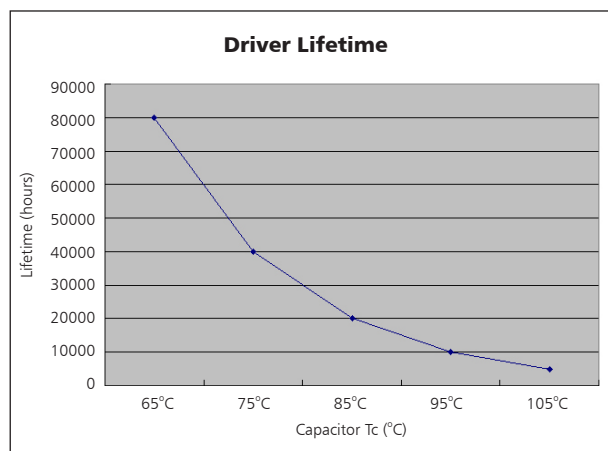

## Temperature

- The testing is operated at 25°C
- The lifetime of capacitor, minimum of 5,000 hours if operated at 105°C, will be doubled whenever the temperature drops 10°C
- The highest withstand temperature of IC, MOS could be 120°C
- The highest withstand temperature of LED junction temperature is 150°C

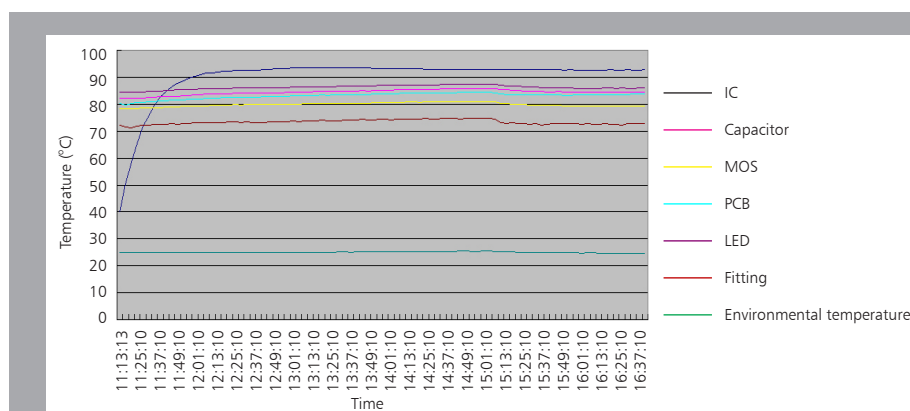

The driver lifespan is based on capacitor working temperature.

# Installation

Install requirements	
A-gap above the fitting	25mm
B-gap to the building material	25mm
C-gap to the thermal insulation	25mm

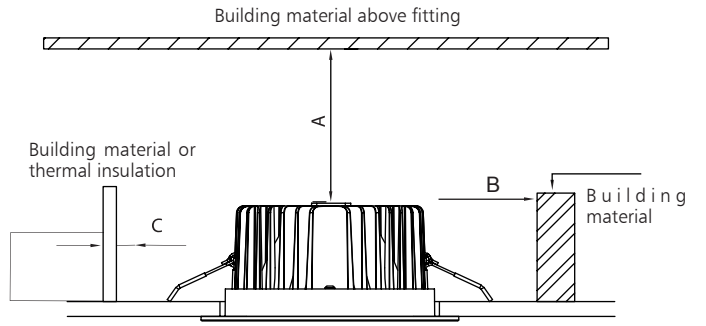

<p><b>Ceiling Opening</b></p> <p style="text-align: right;">1</p>	<p><b>Connect Power supply</b></p> <p style="text-align: right;">2</p>
<p><b>A. Hold back spring clips</b></p> <p><b>B. Push downlight into position</b></p> <p style="text-align: right;">3</p>	<p><b>Finish</b></p> <p style="text-align: right;">4</p>

# Packaging Information

	SIZE(CM)	N.W/pc (KGS)	G.W.(KGS)	Q'TY(PCS)
Carton	54.5*51*35	1.6	23	12

	CTNS	Q'TY(PCS)	VOLUME(CBM)
20" standard container	284	3408	28
40" standard container	568	6816	56

