

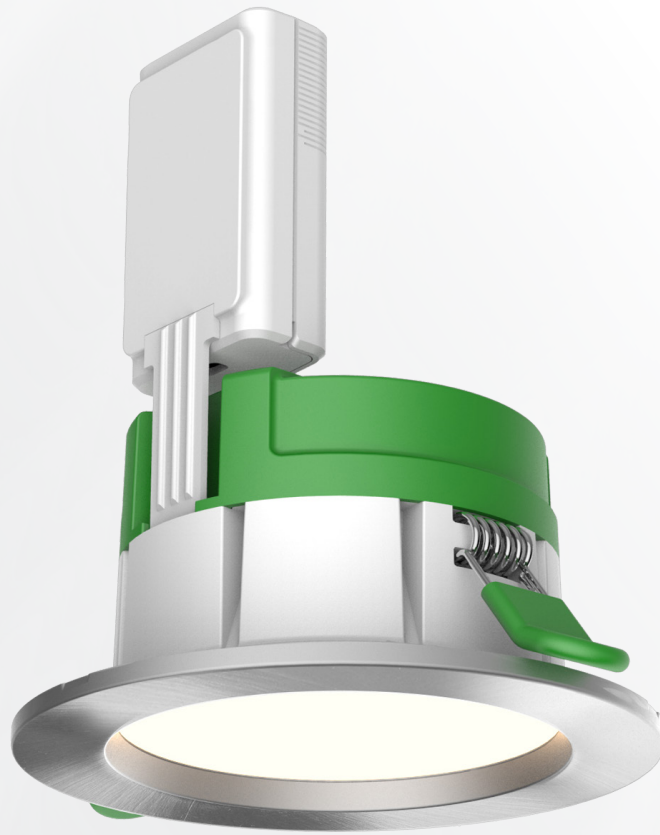

Up-shine[®] Lighting



Technical Application
Guide for UP SHINE
LED Downlight
UP-DL114-3-10W

Introduction

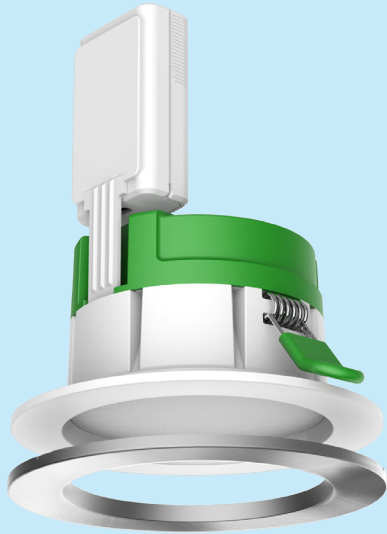

DL114 Down light adopts high lumen SMD LED, PC diffuser with even light output. V0 fire rated plastic housing with internal driver design; it is our most economical and practical downlight version. Dimmable version available, it shares great popularity by the excellent dimming effect, Wiring downlight becomes very easy because the flexible driver box can be bent to achieve the most suitable installation angles.

- Up to 70% energy saving compared to standard CFL
- Long lifetime of 50,000 hours
- Dimmable when using triac dimmer
- 90° wide beam angle
- 90-95mm cutout
- CCT: 3000K 4000K
5000K 5700K
- No UV/IR light
- Environment friendly, without Mercury or any other hazardous substances

Application notes

- IP54 for room side
- Professional electrician for installation only
- Switch off before installation
- Do not touch when in use
- Keep away from hot steam and corrosive gas

Application Areas

It is designed for general lighting applications in office, supermarket, shop, school, hotel, etc. It is also widely used for public areas, such as stairway, lobby, reception, corridors etc.

Certificate

CE **RoHS**



Product Information

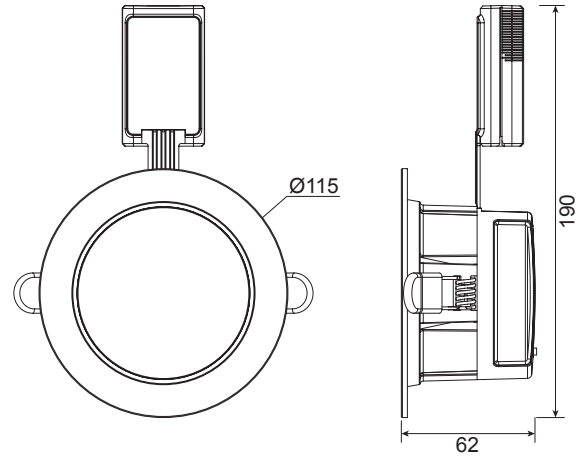

Technical Specifications

| Model | Voltage | Power | Power Factor | Lumen (±5%) | Beam angle | CCT | Lifespan | CRI | Dimmable | Dimension |
|------------------|------------|-------|--------------|-------------|------------|-------|----------|-----|----------|-----------------------------|
| UP-DL114-3-10W | AC100-240V | 10W | ≥0.9 | 840 | 90° | 3000K | 50000h | ≥80 | No | 190*115*62mm cutout 90-95mm |
| UP-DL114-3-10W | AC100-240V | 10W | ≥0.9 | 920 | 90° | 4000K | 50000h | ≥80 | No | 190*115*62mm cutout 90-95mm |
| UP-DL114-3-10W | AC100-240V | 10W | ≥0.9 | 910 | 90° | 5000K | 50000h | ≥80 | No | 190*115*62mm cutout 90-95mm |
| UP-DL114-3-10W | AC100-240V | 10W | ≥0.9 | 900 | 90° | 5700K | 50000h | ≥80 | No | 190*115*62mm cutout 90-95mm |
| UP-DL114-3-10W-D | AC230V | 10W | ≥0.9 | 800 | 90° | 3000K | 50000h | ≥80 | Yes | 190*115*62mm cutout 90-95mm |
| UP-DL114-3-10W-D | AC230V | 10W | ≥0.9 | 880 | 90° | 4000K | 50000h | ≥80 | Yes | 190*115*62mm cutout 90-95mm |
| UP-DL114-3-10W-D | AC230V | 10W | ≥0.9 | 870 | 90° | 5000K | 50000h | ≥80 | Yes | 190*115*62mm cutout 90-95mm |
| UP-DL114-3-10W-D | AC230V | 10W | ≥0.9 | 860 | 90° | 5700K | 50000h | ≥80 | Yes | 190*115*62mm cutout 90-95mm |

Driver data Sheet

| Driver data | DIM | Non-DIM |
|-----------------------------|---------------|------------|
| Input rated Voltage | AC230V | AC100-240V |
| Frequency | 50Hz | 50/60Hz |
| Input Voltage | AC200-240V | AC85-265V |
| Efficiency | ≥82% | ≥86% |
| Total load Wattage | 10W±1W | 10W±1W |
| Power Factor | ≥0.9 | ≥0.9 |
| Rated input current | ≤0.06A | ≤0.12A |
| Full load output Voltage | 55-65V | 55-78V |
| Rated output current | 140mA | 160mA |
| Output current range | 140mA±5% | 160mA±5% |
| Power tolerance | ±5% | ±5% |
| Current output tolerance | ±5% | ±5% |
| Dimming range | 8%-100% | — |
| Dimmer | Triac dimmers | — |
| Short circuit protection | PASS | PASS |
| Over voltage protection | PASS | PASS |
| Over temperature protection | PASS | PASS |
| THD | <18% | <18% |
| Withstand voltage | — | — |

Fixture Compatibility

| Rated Wattage | Electrical Classification | Ingress Protection | Operating Temp | Operating Humidity | Storage Temp |
|---------------|---------------------------|--------------------|----------------|--------------------|--------------|
| 10W | II | IP54 for room side | -20°C~45°C | 0~90% | -20°C~65°C |

Spectral Distribution

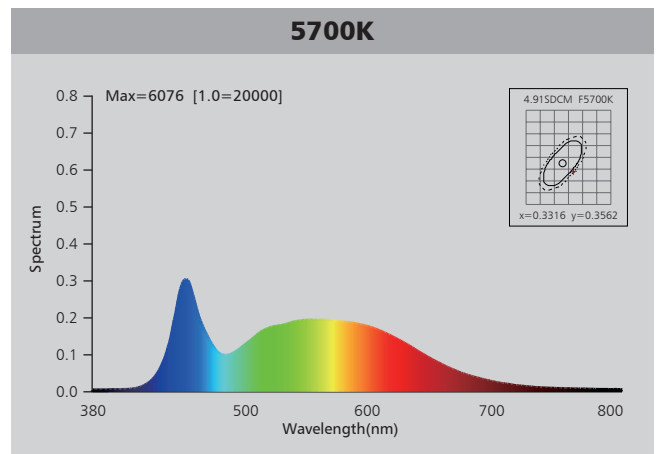
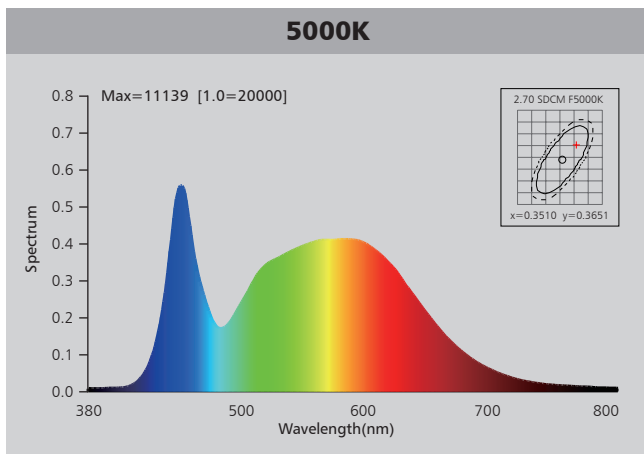
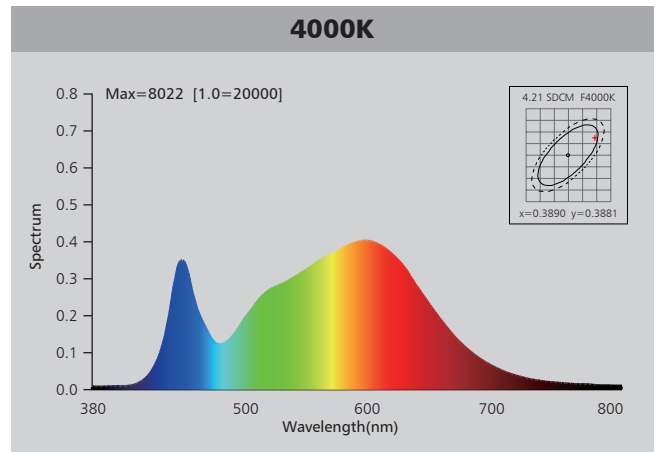
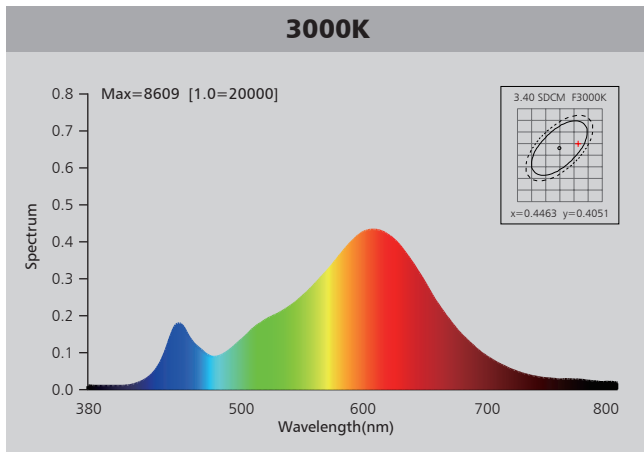

Photometric Diagram

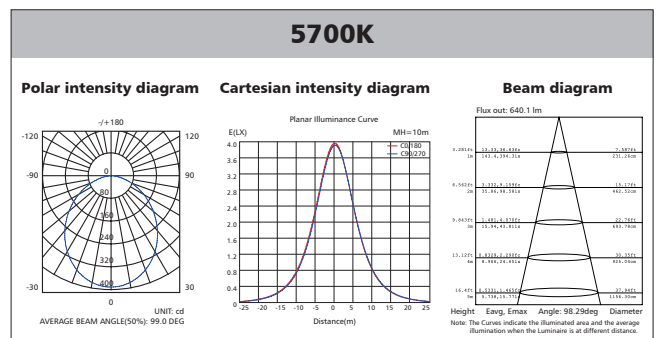
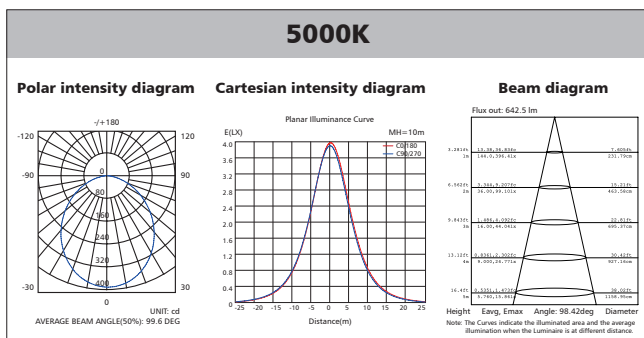
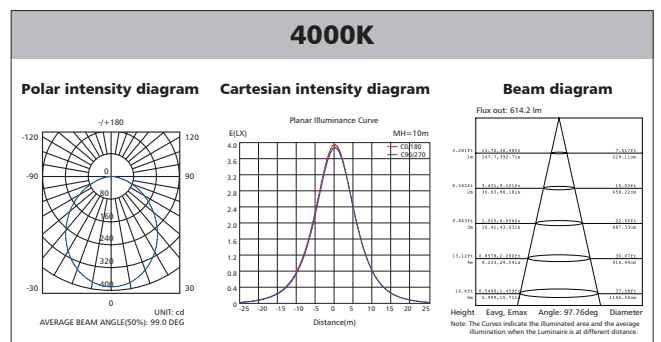
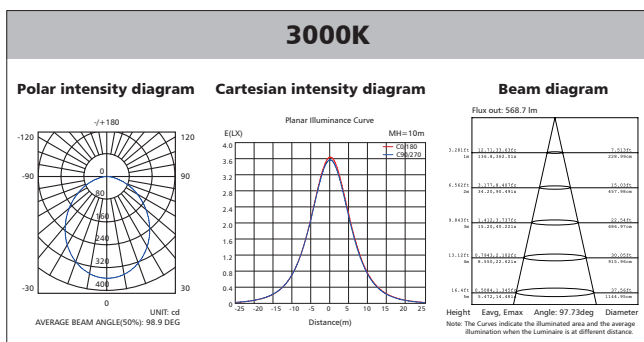

Polar Diagram Comparison

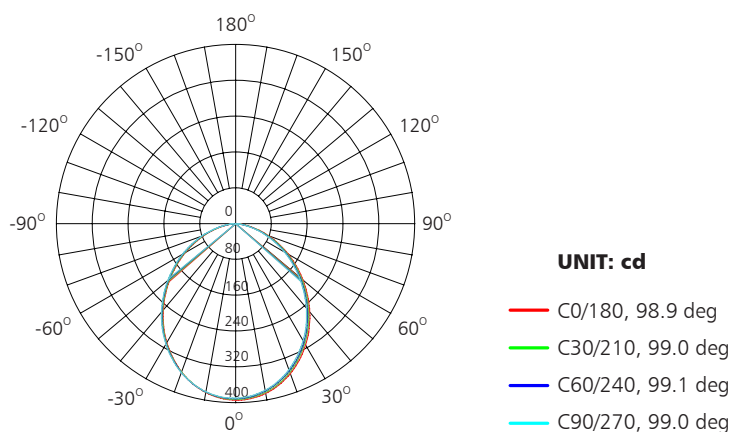

AVERAGE BEAM ANGLE (50%): 99.0DEG



Driver lifetime & LED light decay rate

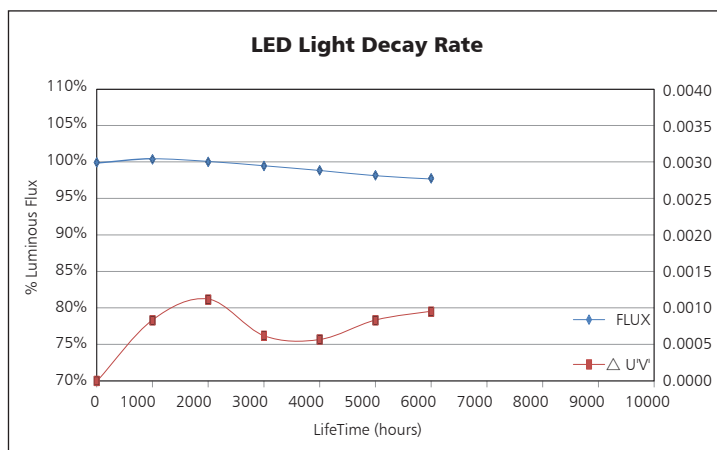
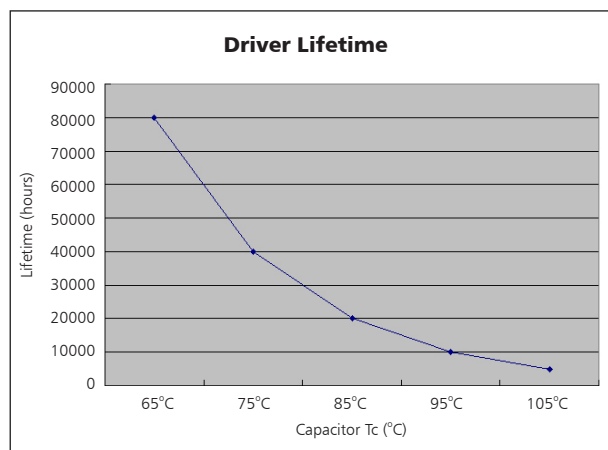

Temperature

- The testing is operated at 25°C
- The lifetime of capacitor, minimum of 5,000 hours if operated at 105°C, will be doubled whenever the temperature drops 10°C
- The highest withstand temperature of IC, MOS could be 120°C
- The highest withstand temperature of LED junction temperature is 150°C

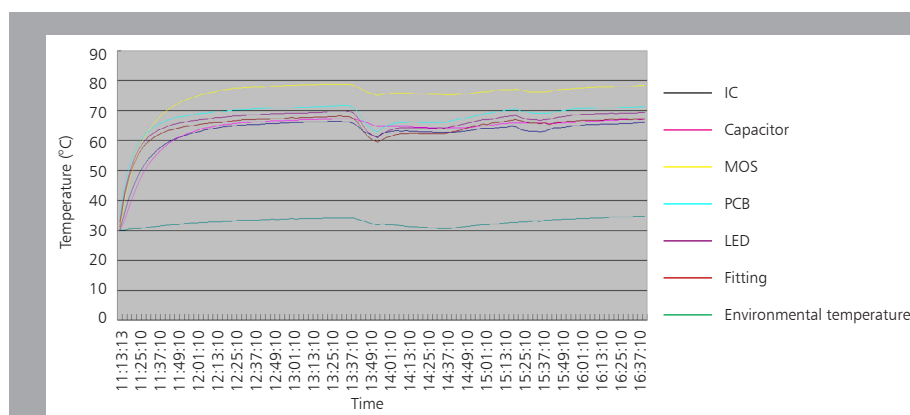

The driver lifespan is based on capacitor working temperature.

Installation

| Install requirements | |
|---------------------------------|------|
| A-gap above the fitting | 25mm |
| B-gap to the building material | 25mm |
| C-gap to the thermal insulation | 25mm |

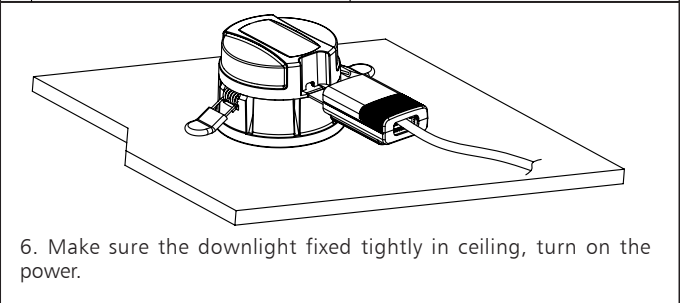
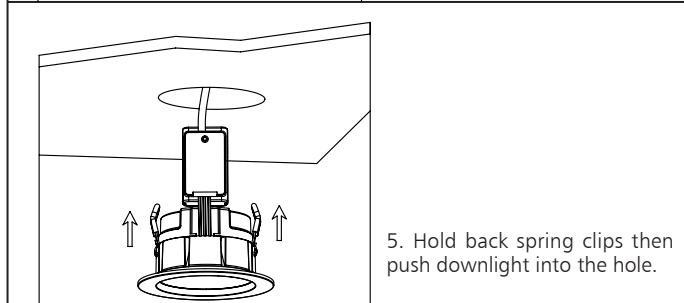
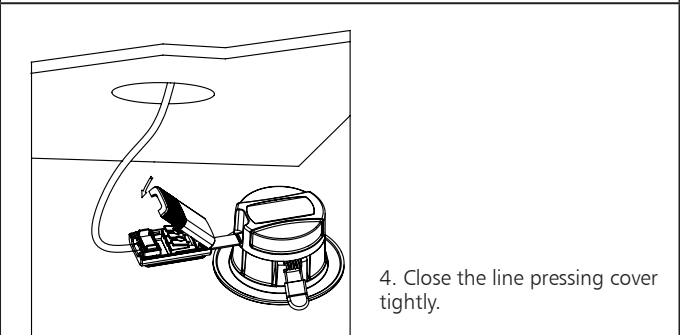
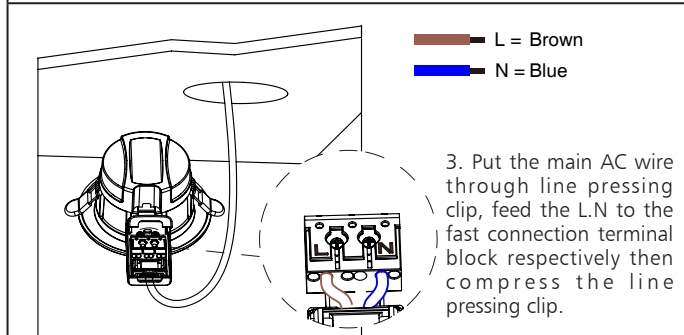
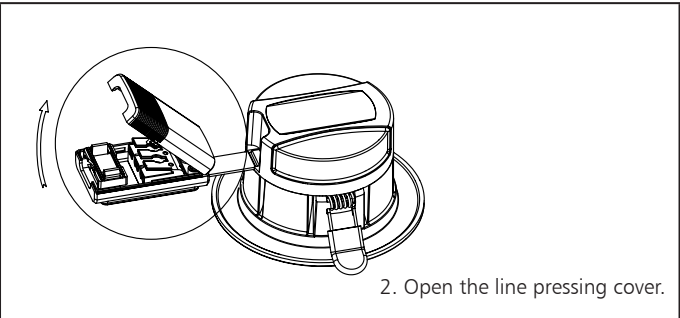
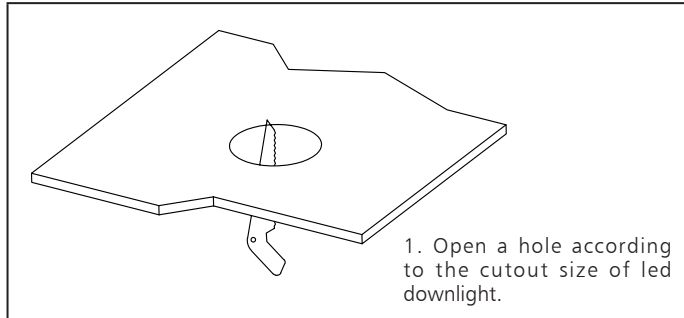
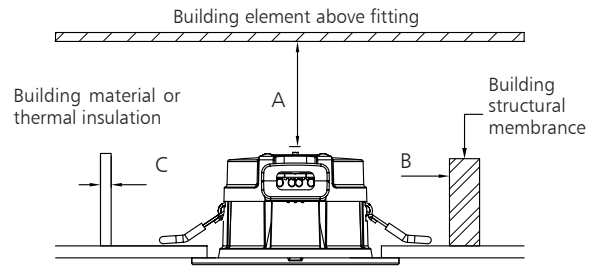

Packaging Information

| | SIZE(CM) | N.W/pc (KGS) | G.W.(KGS) | Q'TY(PCS) |
|--------|------------|--------------|-----------|-----------|
| Carton | 43.5*48*33 | 0.2 | 6.5 | 24 |

| | CTNS | Q'TY(PCS) | VOLUME(CBM) |
|------------------------|------|-----------|-------------|
| 20" standard container | 400 | 9600 | 28 |
| 40" standard container | 800 | 19200 | 56 |

