



Up-shine® Lighting



Technical Application Guide for UP-SHINE LED Downlight

UP-CL88-70-7W

Introduction



 25°

CL88 downlight is developed for Oceania and European market. The advantage is choosing ADC12 Aluminum as lamp fitting, spraying paint process to make lamp smooth and noncorrosive with excellent thermal conductivity. Cutout size both 70mm and 90mm are available. Besides, the horizontal rotation is around 25 degree, creating diversified lighting effects. PMMA diffuser with high reflective paper creates even light output, it is an ideal replacement for customers who have strictly requirements of environmental protection.

- Up to 70% energy saving compared to standard CFL
- Long lifetime of 40,000 hours
- Dimmable when using triac dimmer
- 90° wide beam angle
- Ø68mm cutout
- CCT: 3000K 4000K
5000K 5700K
- No UV/IR light
- Environment friendly, without Mercury or any other hazardous substances

Application notes

- IP20 for indoor use only
- Professional electrician for installation only
- Switch off before installation
- Do not touch when in use
- Keep away from hot steam and corrosive gas

Application Areas

It is designed for general lighting applications in office, supermarket, shop, school, hotel, etc. It is also widely used for public areas, such as stairway, lobby, reception, corridors etc.

Certificate



Product Information

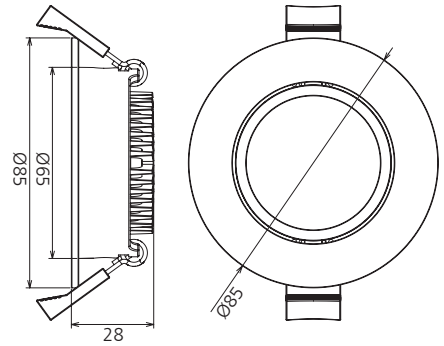

Technical Specifications

Model	Voltage	Power	Power Factor	Lumen (±5%)	Beam angle	CCT	Lifespan	CRI	Dimmable	Dimension
UP-CL88-70-7W	AC230V	7W	≥0.9	505	90°	3000K	40000h	≥80	No	Ø85*28mm cutout 68mm
UP-CL88-70-7W	AC230V	7W	≥0.9	520	90°	4000K	40000h	≥80	No	Ø85*28mm cutout 68mm
UP-CL88-70-7W	AC230V	7W	≥0.9	530	90°	5000K	40000h	≥80	No	Ø85*28mm cutout 68mm
UP-CL88-70-7W	AC230V	7W	≥0.9	550	90°	5700K	40000h	≥80	No	Ø85*28mm cutout 68mm
UP-CL88-70-7W-D	AC230V	7W	≥0.9	500	90°	3000K	40000h	≥80	Yes	Ø85*28mm cutout 68mm
UP-CL88-70-7W-D	AC230V	7W	≥0.9	510	90°	4000K	40000h	≥80	Yes	Ø85*28mm cutout 68mm
UP-CL88-70-7W-D	AC230V	7W	≥0.9	520	90°	5000K	40000h	≥80	Yes	Ø85*28mm cutout 68mm
UP-CL88-70-7W-D	AC230V	7W	≥0.9	530	90°	5700K	40000h	≥80	Yes	Ø85*28mm cutout 68mm

Driver data Sheet

Driver data	DIM	Non dim
Input rated Voltage	AC230V	AC230V
Frequency	50HZ	50HZ
Input Voltage	AC200-240V	AC200-240V
Efficiency	≥78%	≥80%
Total load Wattage	7W±0.5W	7W±0.5W
Power Factor	≥0.9	≥0.9
Rated input current	≤0.04A	≤0.03A
Full load output Voltage	DC28-40V	DC25-42V
Rated output current	170mA	190mA
Output current range	170mA±5%	190mA±5%
Power tolerance	±5%	±5%
Current output tolerance	±5%	±5%
Dimming range	8%-100%	—
Dimmer	Triac dimmers	—
Short circuit protection	PASS	PASS
Over voltage protection	PASS	PASS
Over temperature protection	PASS	PASS
THD	≤40%	≤20%
Withstand voltage	AC3750V	AC3750V

Fixture Compatibility

Rated Wattage	Electrical Classification	Ingress Protection	Operating Temp	Operating Humidity	Storage Temp
7W	II	IP20	-20°C~45°C	0~90%	-20°C~65°C

Spectral Distribution

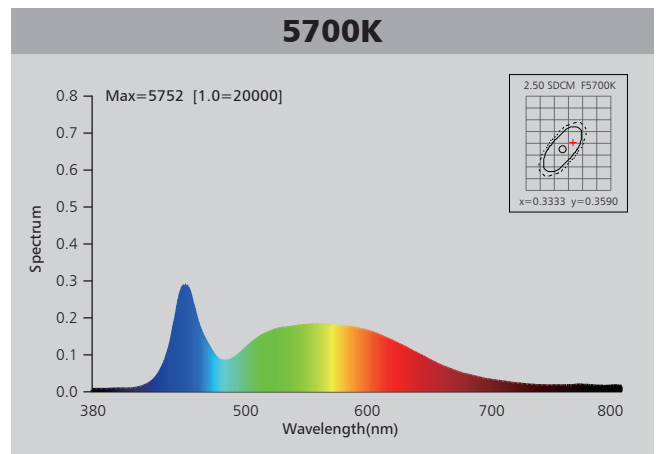
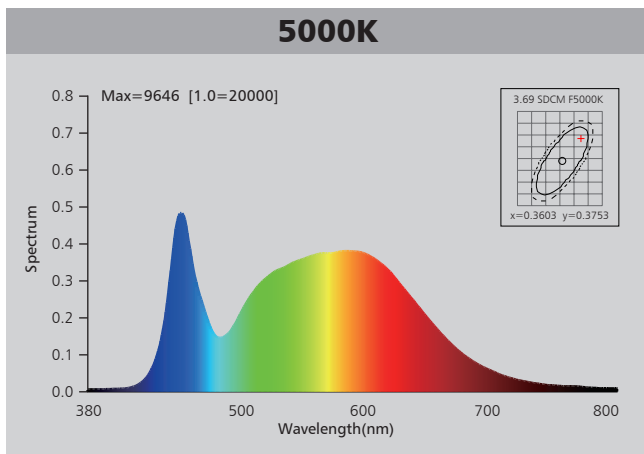
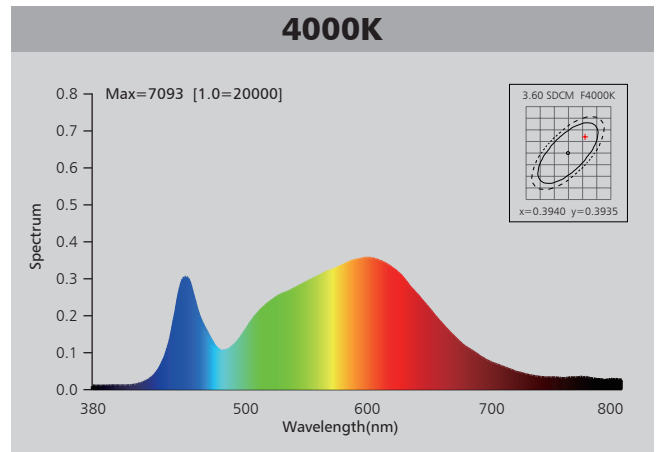
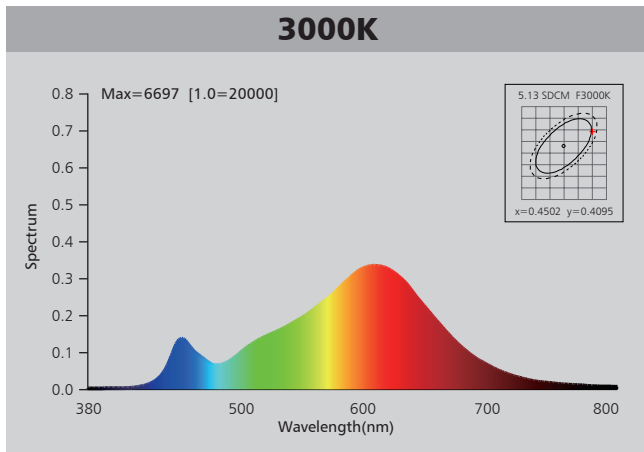

Photometric Diagram

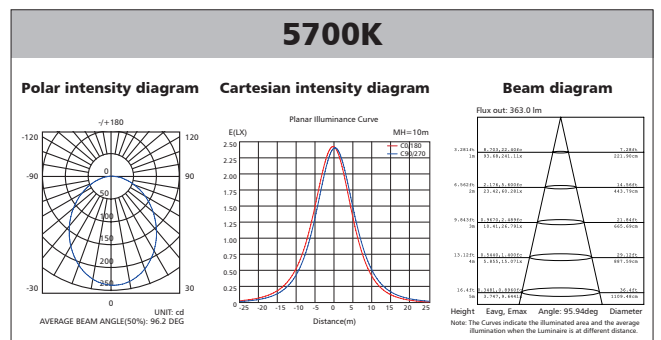
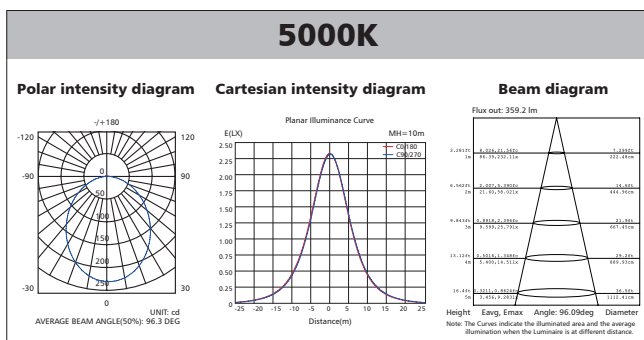
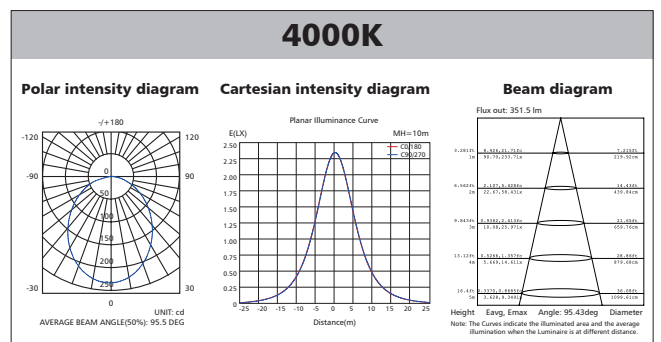
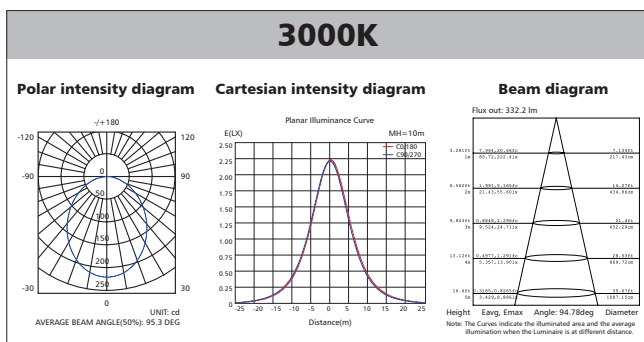

Polar Diagram Comparison

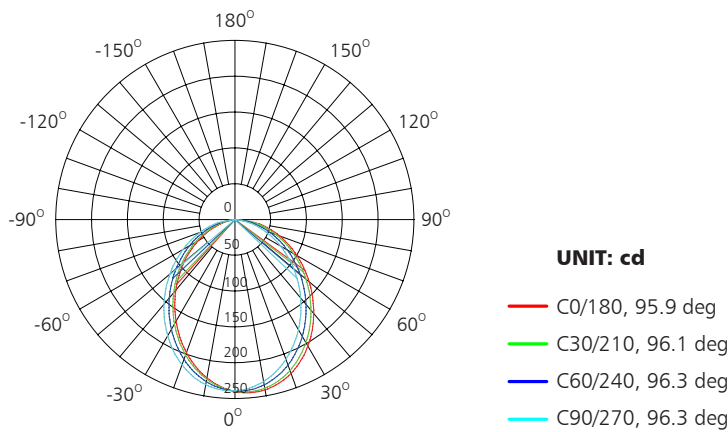

AVERAGE BEAM ANGLE (50%): 96.2DEG



Driver lifetime & LED light decay rate

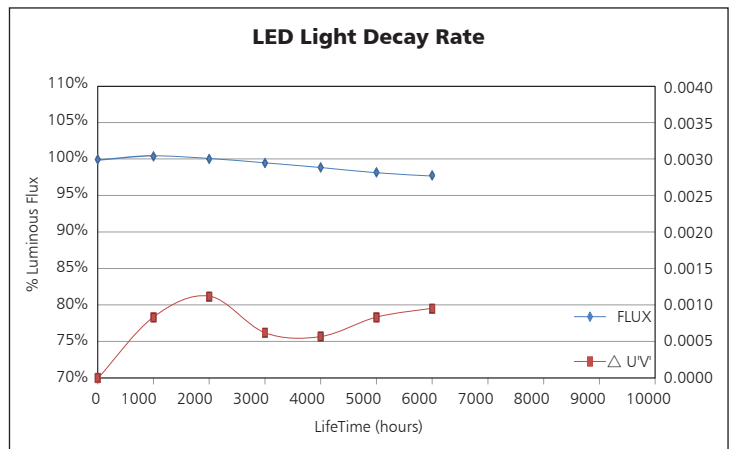
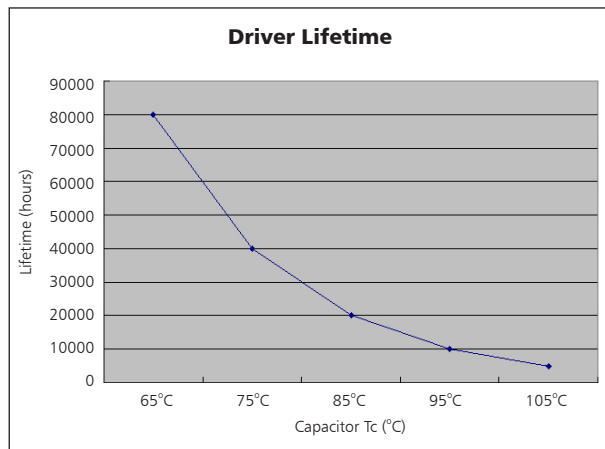

Temperature

- The testing is operated at 25°C
- The lifetime of capacitor, minimum of 5,000 hours if operated at 105°C, will be doubled whenever the temperature drops 10°C
- The highest withstand temperature of IC, MOS could be 120°C
- The highest withstand temperature of LED junction temperature is 150°C

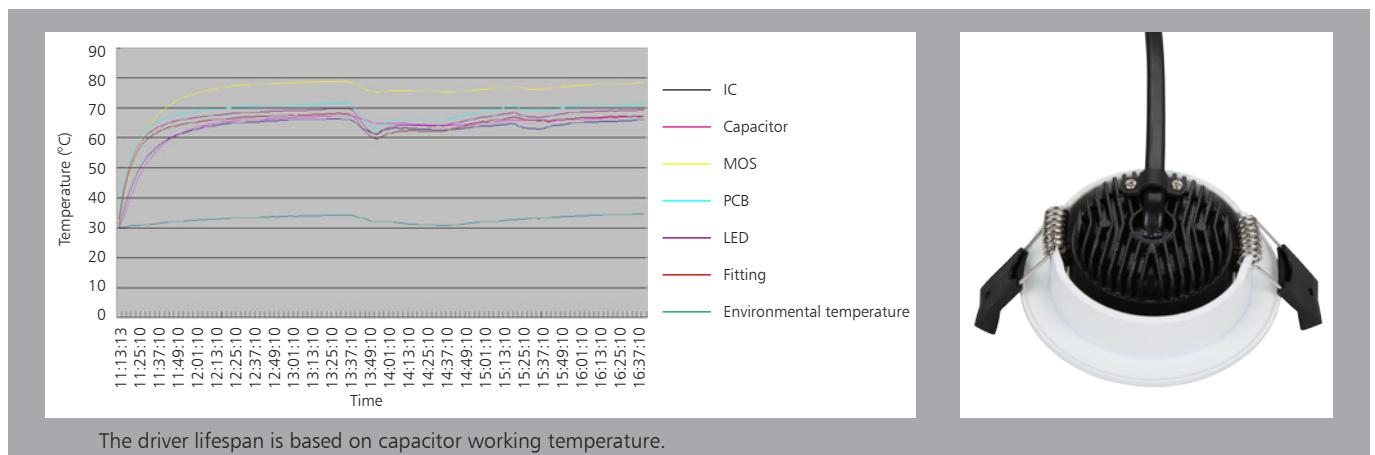

Installation

Install requirements	
A-gap above the fitting	25mm
B-gap to the building material	25mm
C-gap to the thermal insulation	25mm

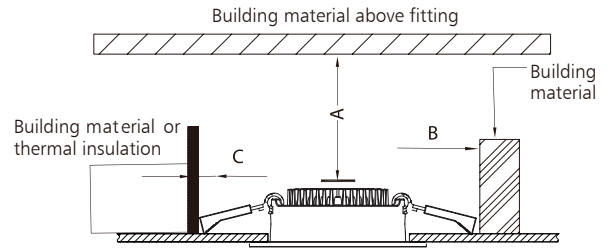

<p>Ceiling Opening</p>	<p>Connect Power supply</p>
<p>A. Hold back spring clips</p> <p>B. Push downlight into position</p>	<p>Spring Clips</p> <p>Ceiling</p>

Packaging Information

	SIZE(CM)	N.W/pc (KGS)	G.W.(KGS)	Q'TY(PCS)
Carton	58*58*18	0.2	15	50

	CTNS	Q'TY(PCS)	VOLUME(CBM)
20" standard container	454	22700	28
40" standard container	908	45400	56

