



# Introduction



Color changeable LED downlight adopts high lumen SMD LED. PMMA diffuser with even light output. The light color is changeable between warm white, neutral white and cold white by ON/OFF switch. Also dimmable with triac dimmers. Multifunctional design shares great popularity.

- Up to 70% energy saving compared to standard CFL
- Long lifetime of 40,000 hours
- 90° wide beam angle
- 200-210mm cutout
- No UV/IR light
- Environment friendly, without Mercury or any other hazardous substances

## Application notes

- IP20/IP44 for indoor use only
- Professional electrician for installation only
- Switch off before installation
- Do not touch when in use
- Keep away from hot steam and corrosive gas

## Operation illustrates:

1. First switch on with initial color A
2. Second switch on, changing into color B
3. Third switch on, changing into color C
4. Fourth switch on, step backward to color A
5. Triac dimmable is available once a color has been selected

## Note

1. The initial color can be customized upon request.
  2. When light is off switch on within 1-4S, color changes from A~C.
  3. When light is off, switch on between 5-8S, restore factory settings.
  4. When light is off, switch on after 15S, memory function activated.
- Color remains the same for the next operation.

## Application Areas

It is designed for general lighting applications in office, supermarket, shop, school, hotel, etc. It is also widely used for public areas, such as stairway, lobby, reception, corridors etc.

## Certificate

CE RoHS SAA

# Product Information

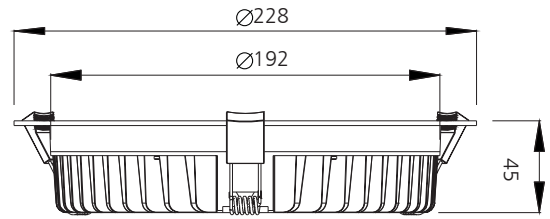

## Technical Specifications

Model	Voltage	Power	Power Factor	Lumen (±5%)	Beam angle	CCT	Lifespan	CRI	Dimmable	Dimension
UP-CL59-8-35W-P	AC230V	35W	≥0.9	2840	90°	2700K	40000h	≥80	Yes	Ø228*45mm cutout 200-210mm
UP-CL59-8-35W-P	AC230V	35W	≥0.9	3500	90°	4000K	40000h	≥80	Yes	Ø228*45mm cutout 200-210mm
UP-CL59-8-35W-P	AC230V	35W	≥0.9	3120	90°	5700K	40000h	≥80	Yes	Ø228*45mm cutout 200-210mm

## Driver data Sheet

Driver data	DIM
Input rated Voltage	AC230V
Frequency	50Hz
Input Voltage	AC200-240V
Efficiency	≥85%
Total load Wattage	35W±5%
Power Factor	≥0.85
Rated input current	≤0.2A
Full load output Voltage	DC29-33V
Rated output current	1050mA
Output current range	1050mA±5%
Power tolerance	±5%
Current output tolerance	±5%
Dimming range	8%-100%
Dimmer	Triac dimmers
Short circuit protection	PASS
Over voltage protection	PASS
Over temperature protection	PASS
THD	≤10%
Withstand voltage	AC3750V

## Fixture Compatibility

Rated Wattage	Electrical Classification	Ingress Protection	Operating Temp	Operating Humidity	Storage Temp
35W	II	IP20 / IP44	-20°C~45°C	0~90%	-20°C~65°C

# Spectral Distribution

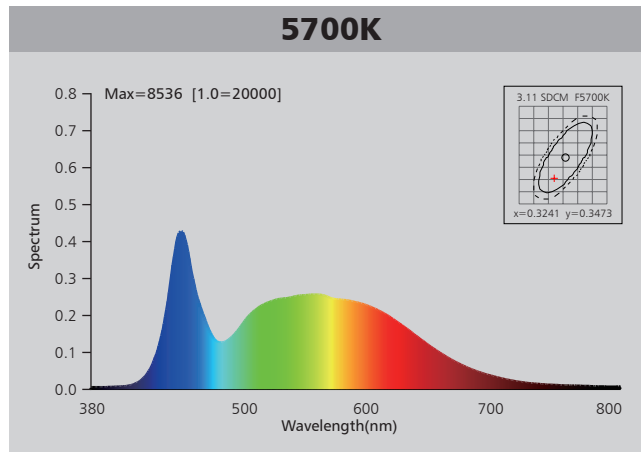
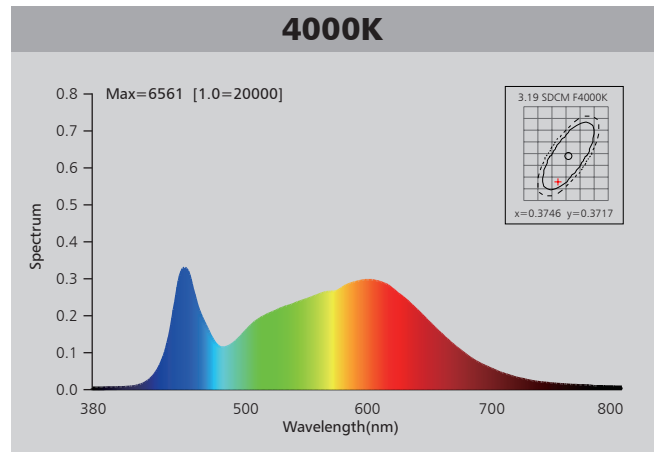
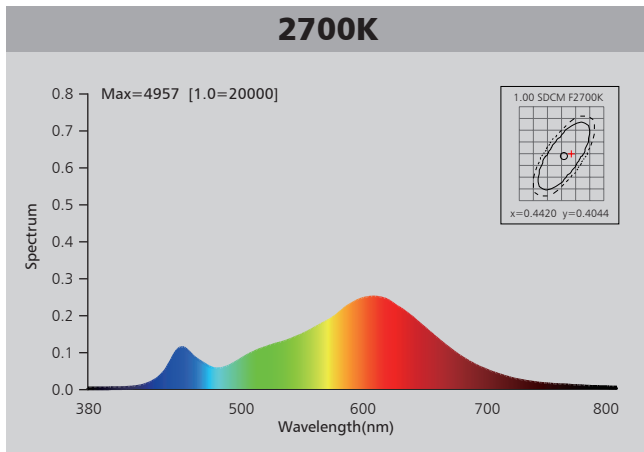

# Photometric Diagram

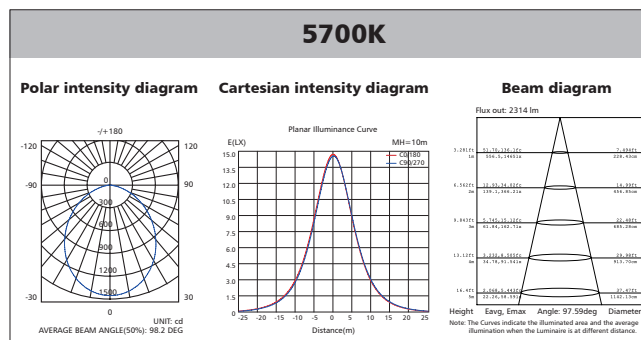
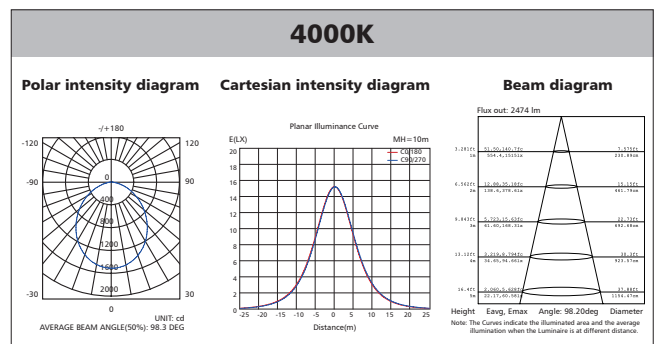
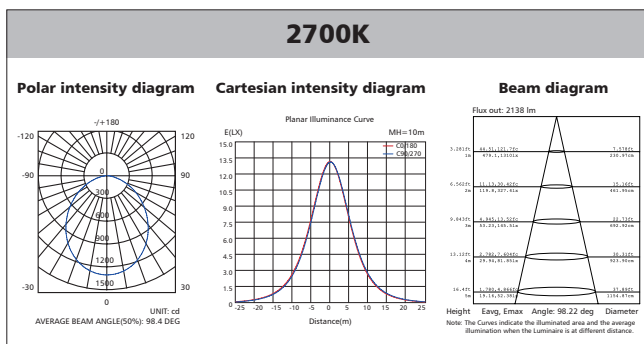

# Polar Diagram Comparison

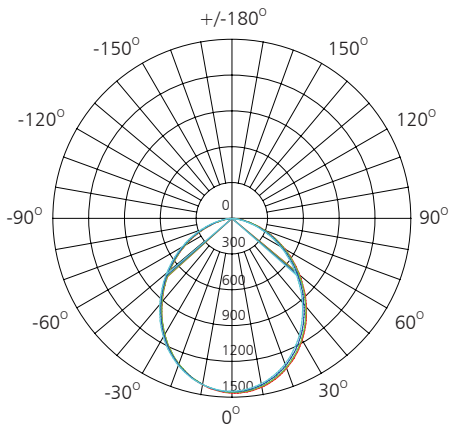

UNIT: cd

- C0/180, 98.3 deg
- C30/210, 98.3 deg
- C60/240, 98.2 deg
- C90/270, 98.2 deg

AVERAGE BEAM ANGLE (50%): 98.2DEG



# Driver lifetime & LED light decay rate

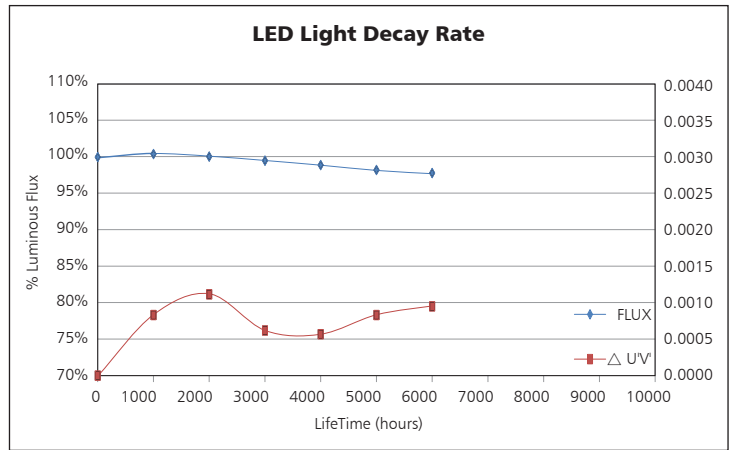
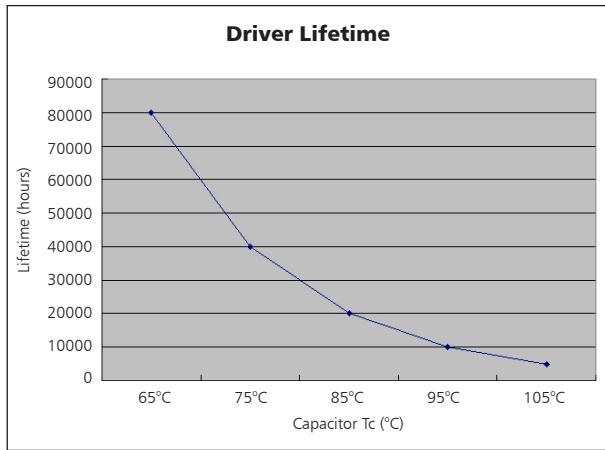

# Temperature

- The testing is operated at 25°C
- The lifetime of capacitor, minimum of 5,000 hours if operated at 105°C, will be doubled whenever the temperature drops 10°C
- The highest withstand temperature of IC, MOS could be 120°C
- The highest withstand temperature of LED junction temperature is 150°C

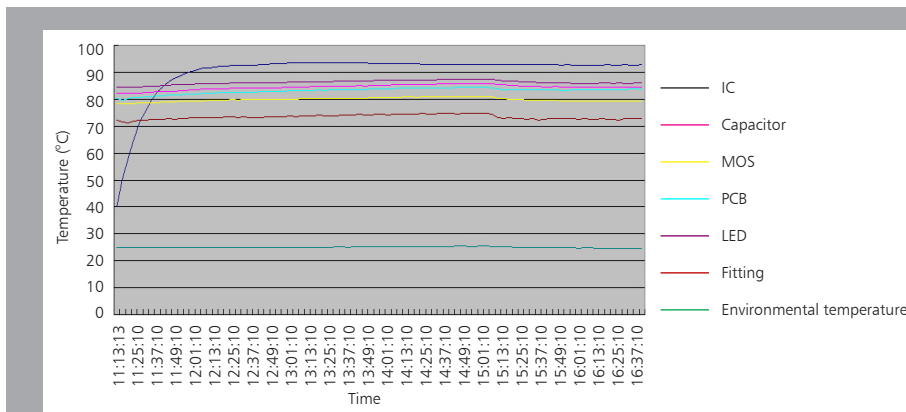

The driver lifespan is based on capacitor working temperature.

# Installation

Install requirements	
A-gap above the fitting	25mm
B-gap to the building material	25mm
C-gap to the thermal insulation	25mm

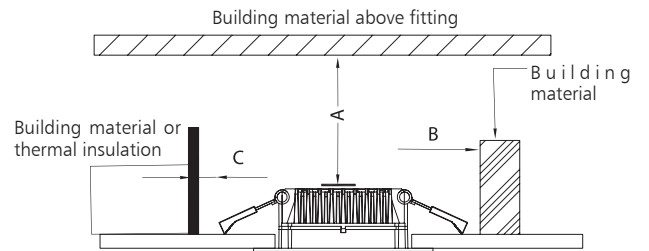

<p><b>Ceiling Opening</b></p>	<p><b>Connect Power supply</b></p>
<p><b>A. Hold back spring clips</b></p>	<p><b>Finish</b></p>

# Packaging Information

	SIZE(CM)	N.W/pc (KGS)	G.W.(KGS)	Q'TY(PCS)
Carton	51.5*27*40.5	0.94	11.7	10

	CTNS	Q'TY(PCS)	VOLUME(CBM)
20" standard container	488	4880	28
40" standard container	976	9760	56

