

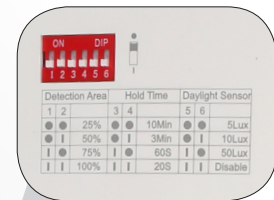

# UPSHINE<sup>®</sup>



## Technical Application Guide for UP SHINE LED Ceiling light

UP-AL08-10-12W-MS

# Introduction

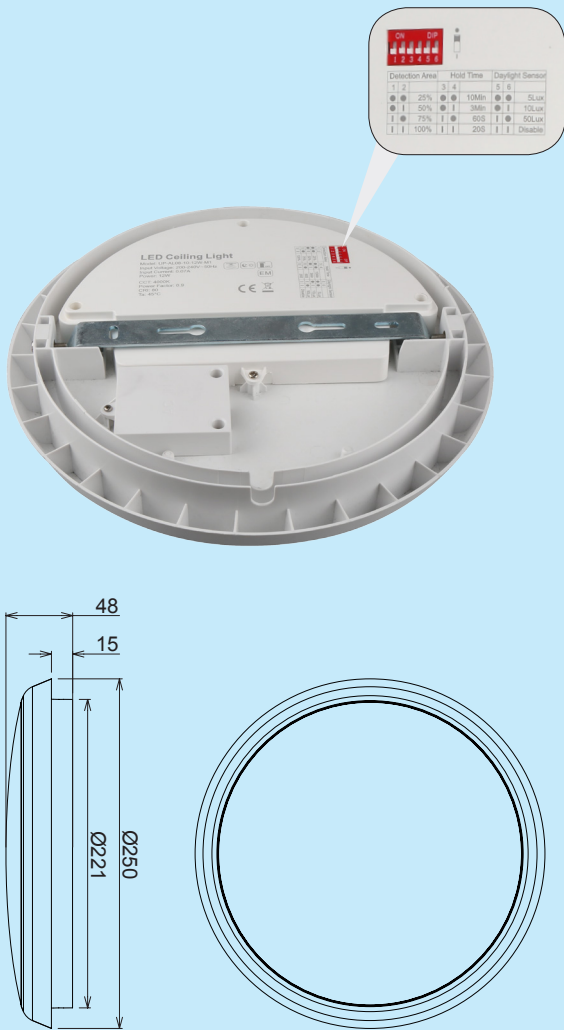

Up-shine surface mounted led ceiling light adopts high lumen SMD led, fire rated PC diffuser with even light output. Super slim design with elegant and modern outline makes it more popular nowadays. Humanized sensor design, by selecting the combination on the switch, sensor data can be precisely set for each specific application. Detection area, hold time and daylight sensor lux setting can be adjustable according to customer's different request, Smart IC control, emergency function switches automatically once the power is switched off, and these humanized designs give customer a new and comfortable experience they never had before.

- Up to 70% energy saving compared to standard CFL
- Long lifetime of 40,000 hours
- 120° wide beam angle
- CCT: 3000K 4000K 5000K 5700K
- No UV/IR light
- Environment friendly, without Mercury or any other hazardous substances

## Application Areas

Applicable for corridor, basement, garage, warehouse, monitoring, and other places of energy-saving indoor and outdoor lighting.

## Certificate



## Detection Pattern

Ceiling Mounting pattern (Unit: m)

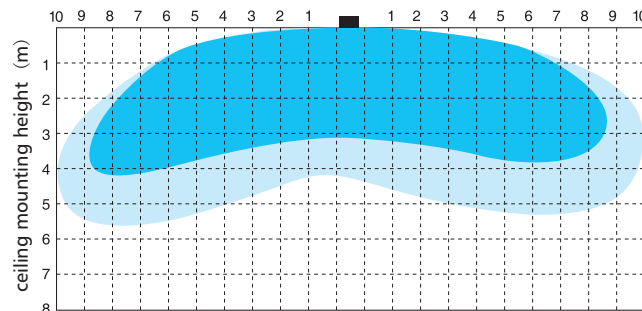

Wall Mounting pattern (Unit: m)

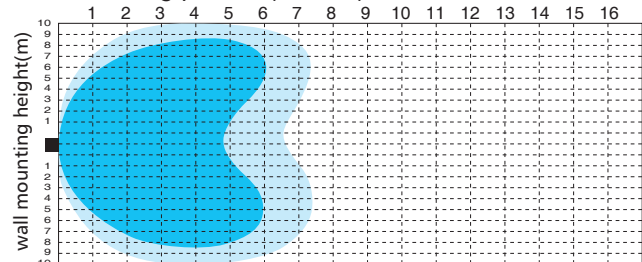

■ High detection area ■ Low detection area



# Built-in Emergency & Sensor Function

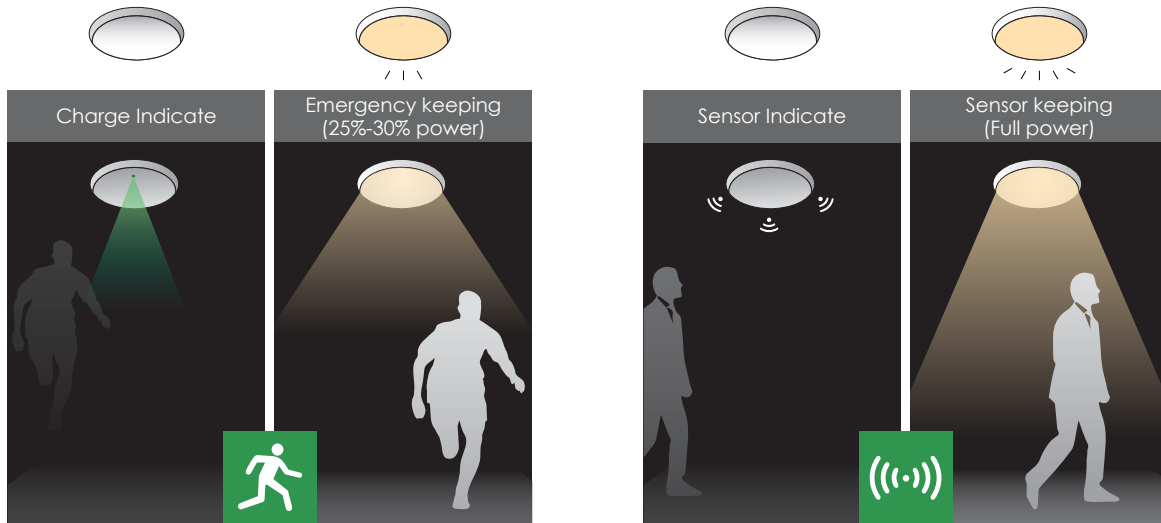

## Daylight & Microwave Sensor

### Detection area:

- ◆ 140 degree wide detective beam angle with 5~7 meters distance.

### Working pattern:

- ◆ With sufficient natural light, when illuminance is more than the setting lux, the light does not switch on when presence detected.
- ◆ With insufficient natural light:
  - When illuminance is less than the setting lux, the light switches on automatically when presence detected.
  - With presence detected, light will never switch off, even the nature light is sufficient.
  - After presence left, any movement detected within time-delay, the light will continuously work for another hold time, then switch off automatically until next movement detected.

## Sensor Setting:

Detection Area		
1	2	
●	●	25%
●		50%
	●	75%
		100%

Hold Time		
3	4	
●	●	10Min
●		3Min
	●	60S
		20S

Daylight Sensor		
●	●	5Lux
●		10Lux
	●	50Lux
		Disable

### Detection area:

Detection area can be reduced by selecting the combination on the DIPswitches to fit precisely each application.

### Hold time:

Refers to the time period the lamp remains at 100% illumination after nomotion detected.

### Daylight sensor:

The sensor can be set to only allow the lamp to illuminate below a defined ambient brightness threshold. When set to Disable mode, the daylight sensor will switch on the lamp when motion is detected regardless of ambient light level. 50lux: twilight operation, 10lux, 5lux: darkness operation only.

## Emergency

Smart IC control.

- ◆ Emergency function switches automatically between power cut and power restoration.
- ◆ Li battery, high efficiency
- ◆ Battery duration: 3 hours@4W
- ◆ Charge period: 24 hours

## Technical Specifications

Model	Voltage	Power	Power Factor	Lumen (±5%)	Beam angle	CCT	Lifespan	CRI	Dimmable	Dimension
UP-AL08-10-12W-MS	AC230V	12W	≥0.9	1140	120°	3000K	40000h	≥80	No	∅250*48mm
UP-AL08-10-12W-MS	AC230V	12W	≥0.9	1260	120°	4000K	40000h	≥80	No	∅250*48mm
UP-AL08-10-12W-MS	AC230V	12W	≥0.9	1270	120°	5000K	40000h	≥80	No	∅250*48mm
UP-AL08-10-12W-MS	AC230V	12W	≥0.9	1270	120°	5700K	40000h	≥80	No	∅250*48mm

## Driver data Sheet

Driver data	Sensor	Emergency	Main Power
Input rated Voltage	AC230V	AC230V	AC230V
Frequency	50Hz	50Hz	50Hz
Input Voltage	AC200-240V	AC200-240V	AC200-240V
Efficiency	—	≥70%	≥88%
No load wattage	—	—	≤0.4W
Total load Wattage	2W±0.5W	4W±0.5W	12W±1W
Power Factor	—	—	≥0.9
Rated input current	≤0.02A	≤0.04A	≤0.07A
Full load output Voltage	—	DC24-38V	60-75V
Rated output current	—	100-170mA	150mA
Output current range	—	—	150mA±5%
Power tolerance	—	—	±5%
Current output tolerance	—	—	±5%
Hold time	20S, 60S, 3Min, 10Min	—	—
Detection distance	5-7m(25%, 50%, 75%, 100%)	—	—
Daylight Sensor	5Lux, 10Lux, 50Lux, Disable	—	—
Battery duration	—	3h@4W	—
Charge Period	—	24h	—
Short circuit protection	—	—	PASS
Over voltage protection	—	—	PASS
Over temperature protection	—	—	PASS
Withstand voltage	—	—	AC3750V

## Fixture Compatibility

Rated Wattage	Electrical Classification	Ingress Protection	Operating Temp	Operating Humidity	Storage Temp
12W	II	IP40	-20°C~45°C	0~90%	-20°C~65°C

## Wiring Diagram:

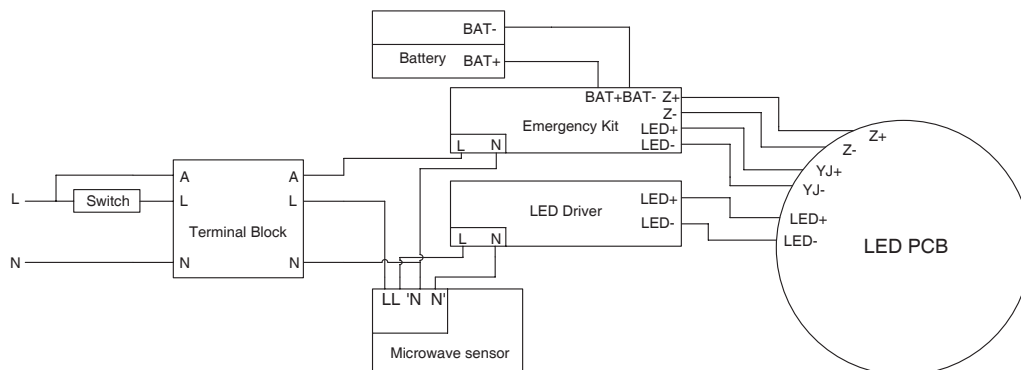

# Spectral Distribution

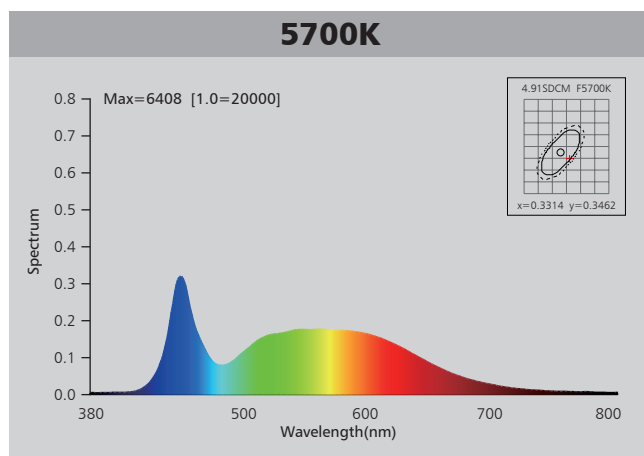
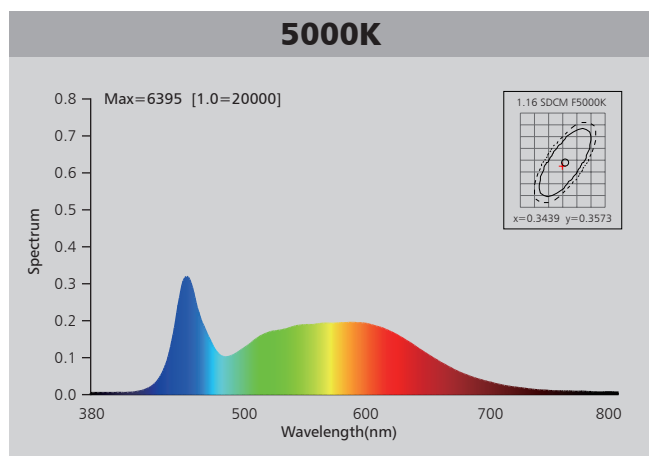
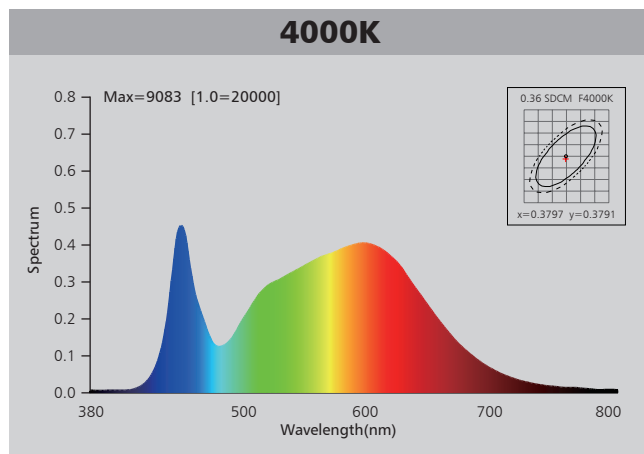
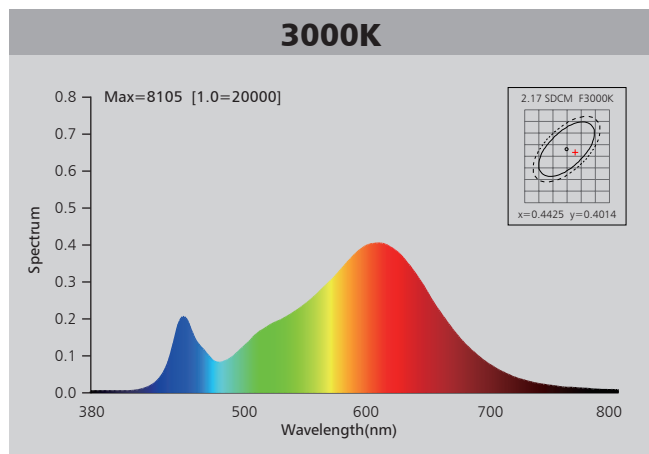

# Photometric Diagram

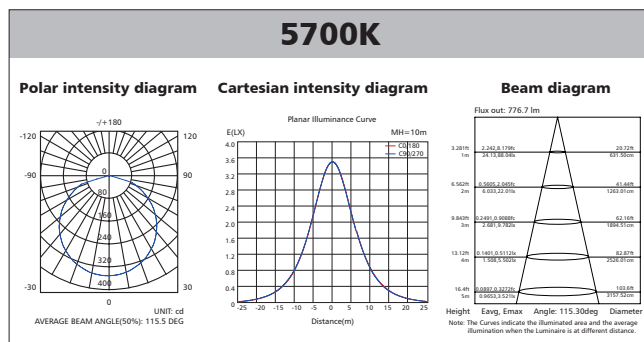
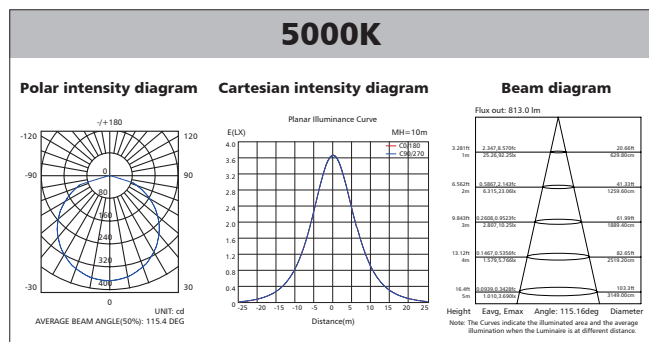
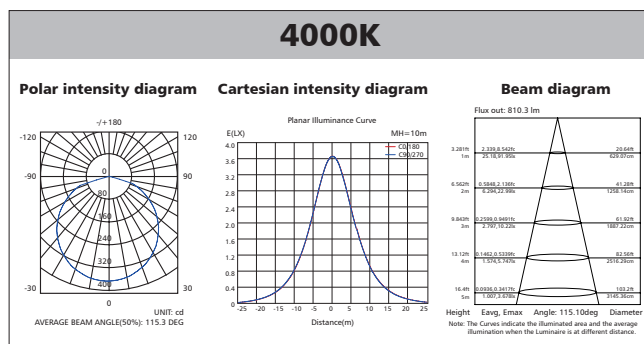
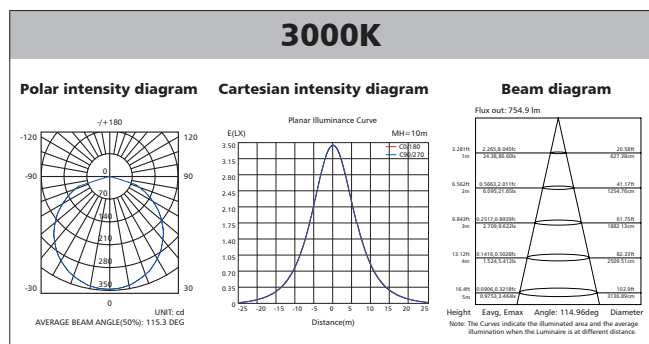

## Polar Diagram Comparison

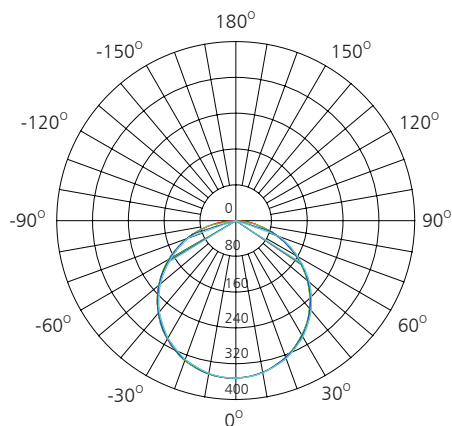

UNIT: cd

- C0/180, 115.4 deg
- C30/210, 115.7 deg
- C60/240, 115.6 deg
- C90/270, 115.3 deg



AVERAGE BEAM ANGLE (50%): 115.5 DEG

## Driver lifetime & LED light decay rate

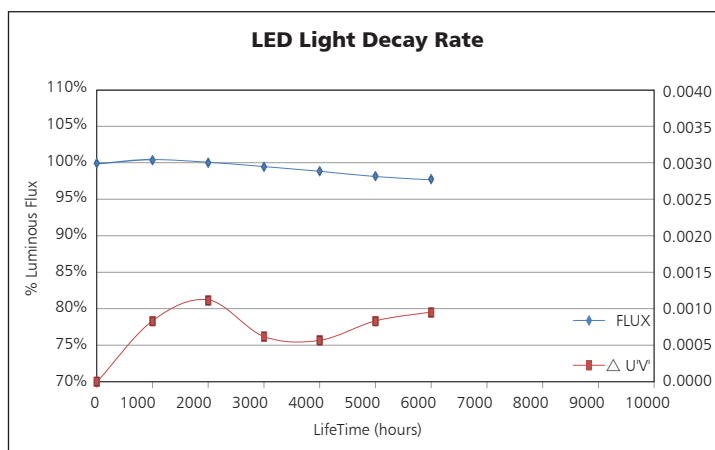
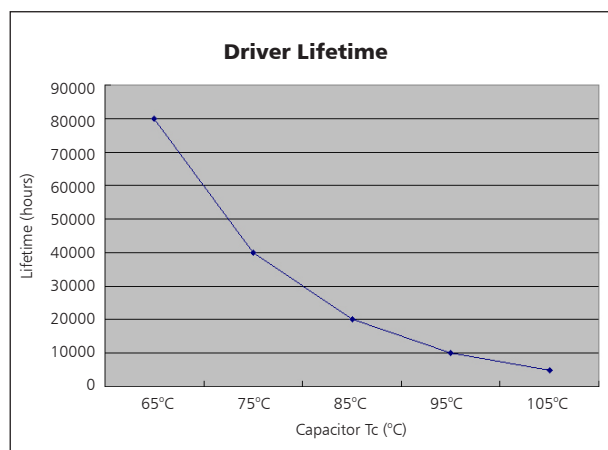

## Temperature

- The testing is operated at 25°C
- The lifetime of capacitor, minimum of 5,000 hours if operated at 105°C, will be doubled whenever the temperature drops 10°C
- The highest withstand temperature of IC, MOS could be 120°C
- The highest withstand temperature of LED junction temperature is 150°C

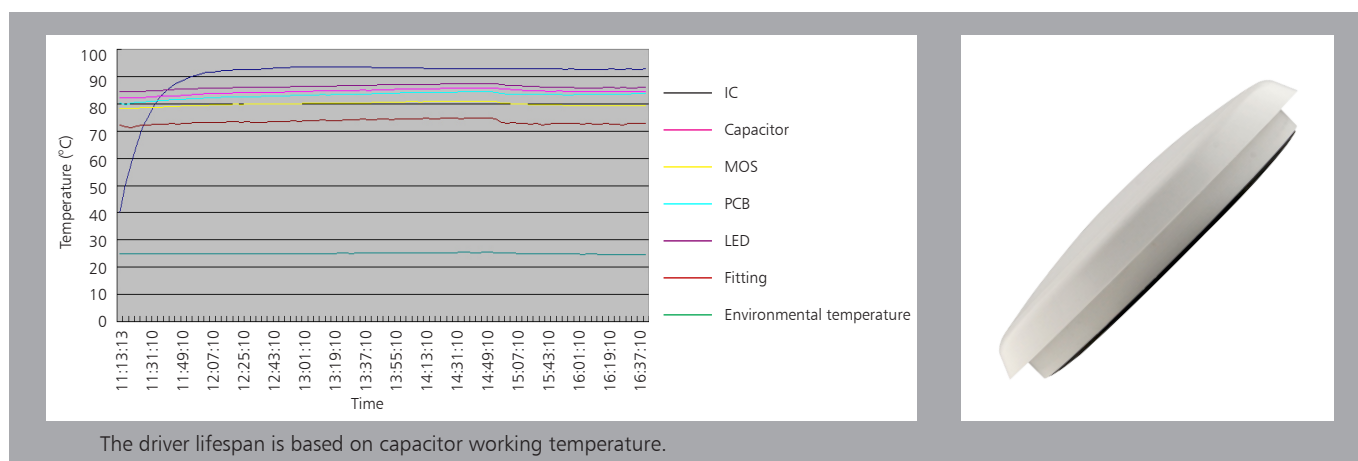

The driver lifespan is based on capacitor working temperature.

# Installation

1. Take out ceiling light and accessory pack from box.

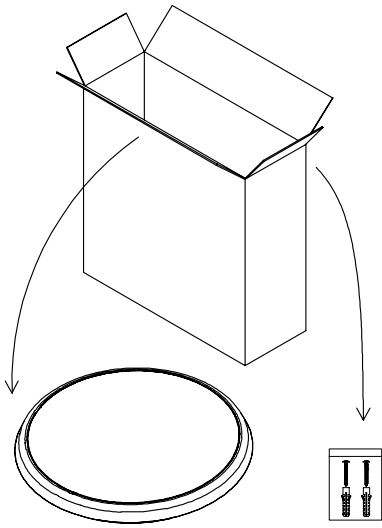

2. Knock-in the plastic anchor into ceiling, remove screw, take out bracket.

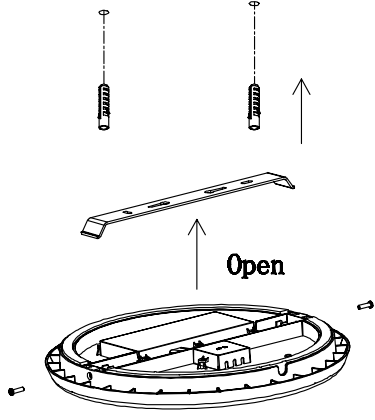

**Open**

3. Fix bracket with screw into the ceiling.

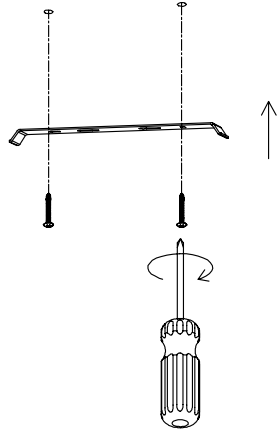

4. Selecting the combination on switch, sensor data can be precisely set for each specific application.

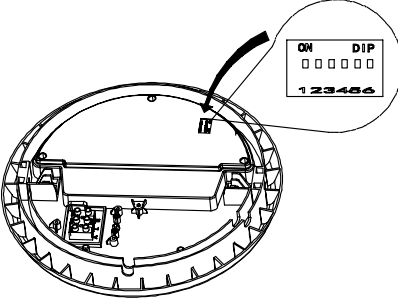

5. Open junction box, wire "A" "L" "N" to terminal block and mount ceiling light into the right place.

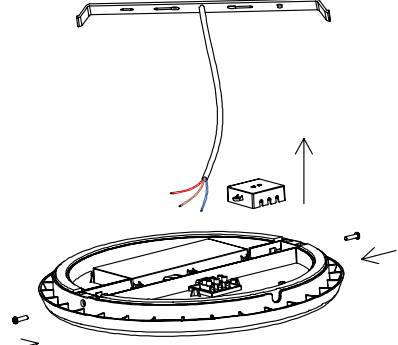

— A = UNSWITCHED  
— L = SWITCHED  
— N = NEUTRAL

6. Switch on.

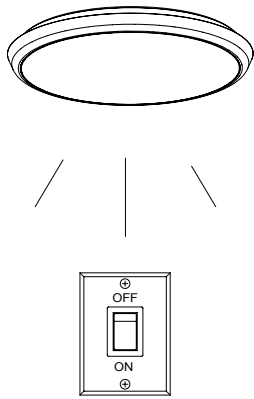

# Packaging Information

	SIZE(CM)	N.W/pc (KGS)	G.W.(KGS)	Q'TY(PCS)
Carton	60*53.5*28.5	0.61	16.8	20

	CTNS	Q'TY(PCS)	VOLUME(CBM)
20" standard container	302	6040	28
40" standard container	604	12080	56

