



Up-shine® Lighting



Technical Application
Guide for UP-SHINE
LED Batten

UP-DB21C-900-30W

Introduction



Up-shine batten realizes elegant design, low cost, super slim construction and superior capability, aluminium profile body for good thermal dissipate, surface color treatment is customizable. Easy installation provided with surface mounted and suspended. It is a high efficient and low cost product with quite large potential market.

- Up to 70% energy saving compared to standard CFL
- Long lifetime of 50,000 hours
- 120° wide beam angle
- CCT: 3000K 4000K 5000K 5700K
- No UV/IR light
- Environment friendly, without Mercury or any other hazardous substances
- Internal Driver

Application notes

- IP20 for indoor use only
- The lamp must be installed by professional electrician
- Ensure the power supply is switched off before fitting this product
- Do not touch the lamp when in use
- Keep away from hot steam and corrosive gas

Application Areas

Widely used in office, meeting room, hotel, school etc.

Certificate



Product Information

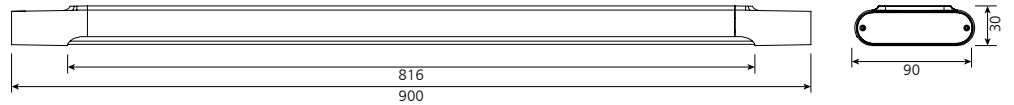

Technical Specifications

Model	Voltage	Power	Power Factor	Lumen (±5%)	Beam angle	CCT	Lifespan	CRI	Dimmable	Dimension
UP-DB21C-900-30W	AC100-277V	30W	≥ 0.9	3060	120°	3000K	50000h	≥80	No	L900*W90*H30mm
UP-DB21C-900-30W	AC100-277V	30W	≥ 0.9	3450	120°	4000K	50000h	≥80	No	L900*W90*H30mm
UP-DB21C-900-30W	AC100-277V	30W	≥ 0.9	3150	120°	5000K	50000h	≥80	No	L900*W90*H30mm
UP-DB21C-900-30W	AC100-277V	30W	≥ 0.9	3030	120°	5700K	50000h	≥80	No	L900*W90*H30mm
UP-DB21C-900-30W-D	AC230V	30W	≥ 0.9	2970	120°	3000K	50000h	≥80	Yes	L900*W90*H30mm
UP-DB21C-900-30W-D	AC230V	30W	≥ 0.9	3300	120°	4000K	50000h	≥80	Yes	L900*W90*H30mm
UP-DB21C-900-30W-D	AC230V	30W	≥ 0.9	3030	120°	5000K	50000h	≥80	Yes	L900*W90*H30mm
UP-DB21C-900-30W-D	AC230V	30W	≥ 0.9	2940	120°	5700K	50000h	≥80	Yes	L900*W90*H30mm

Driver data Sheet

Driver data	DIM	Main Power
Input rated Voltage	AC230V	AC100-277V
Frequency	50Hz	50/60Hz
Input Voltage	AC200-240V	AC90-305V
Efficiency	≥85%	≥90%
Total load Wattage	2*15W±1W	2*15W±1W
Power Factor	≥0.9	≥0.9
Rated input current	≤0.09A*2	≤0.17A*2
Full load output Voltage	DC60-75V	DC60-80V
Rated output current	200mA*2	200mA*2
Output current range	(200mA±5%)*2	(200mA±5%)*2
Power tolerance	±5%	±5%
Current output tolerance	±5%	±5%
Dimming range	8%-100%	—
Dimmer	Triac dimmers	—
Short circuit protection	PASS	PASS
Over voltage protection	PASS	PASS
Over temperature protection	PASS	PASS
THD	—	—
Withstand voltage	—	—

Fixture Compatibility

Rated Wattage	Electrical Classification	Ingress Protection	Operating Temp	Operating Humidity	Storage Temp
30W	I	IP20	-20°C~45°C	0~90%	-20°C~65°C

Spectral Distribution

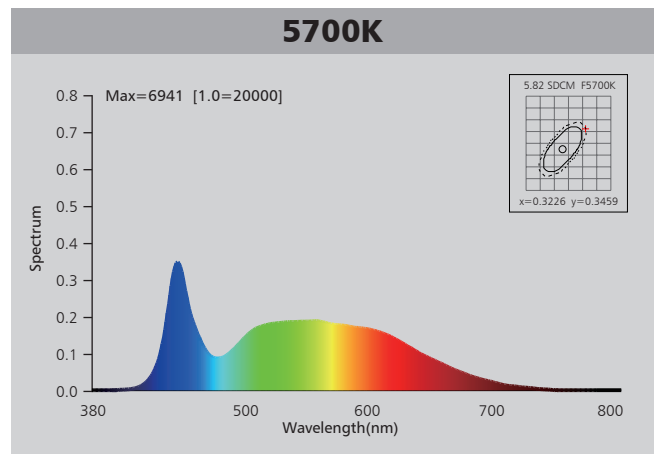
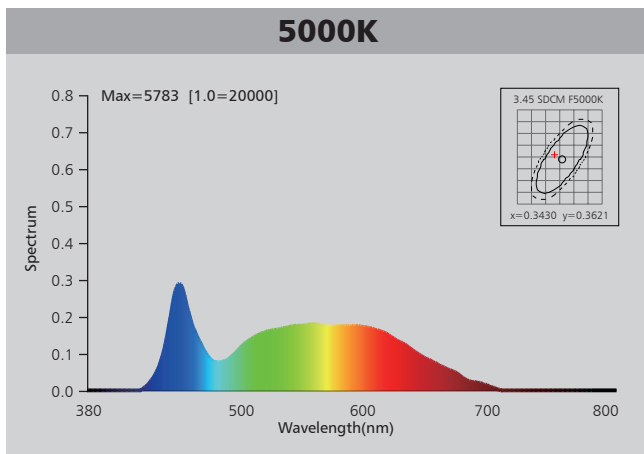
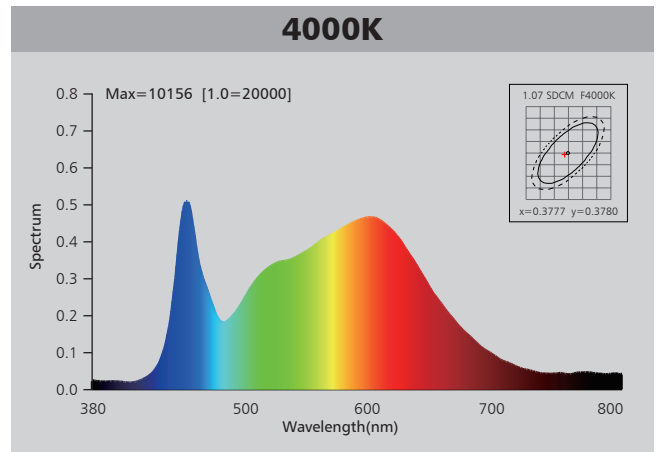
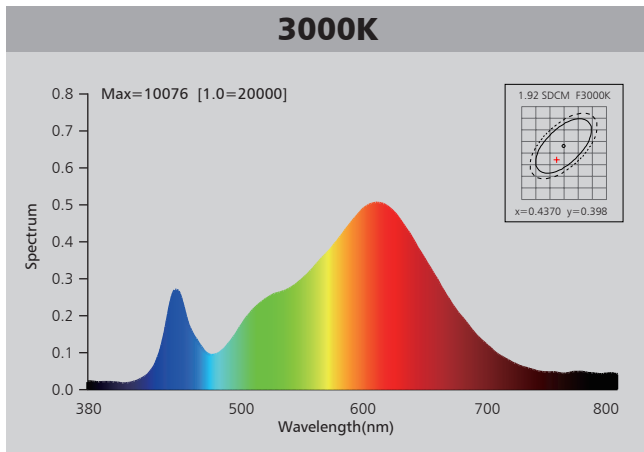

Photometric Diagram

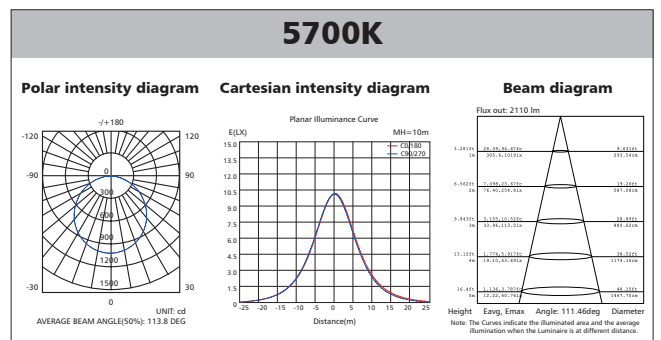
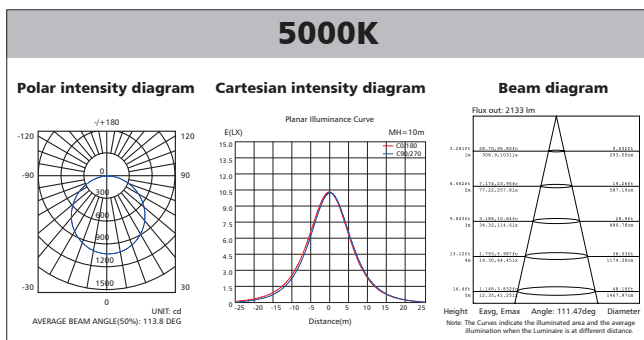
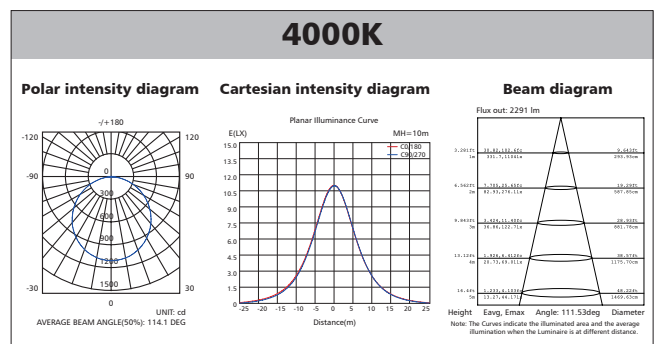
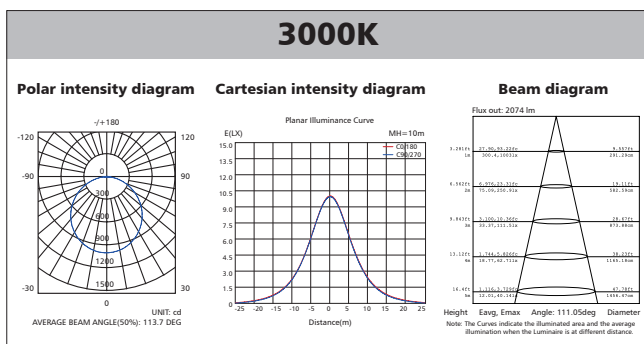

Polar Diagram Comparison

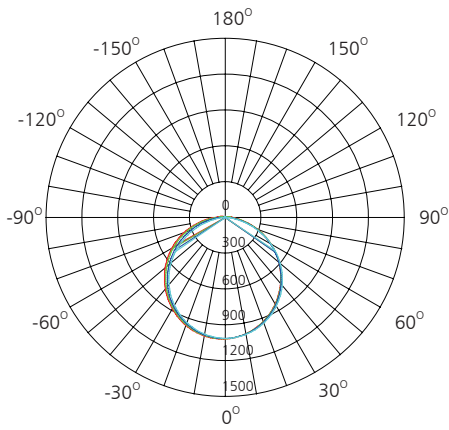

UNIT: cd

- C0/180, 116.1 deg
- C30/210, 115.0 deg
- C60/240, 112.5 deg
- C90/270, 111.6 deg



AVERAGE BEAM ANGLE (50%): 113.8DEG

Driver lifetime & LED light decay rate

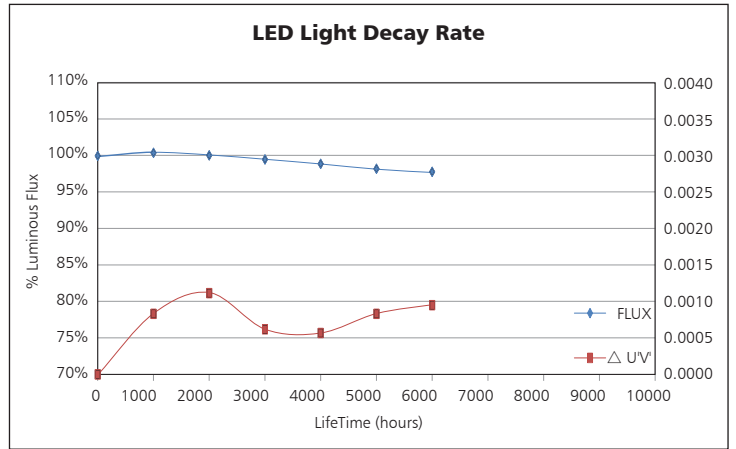
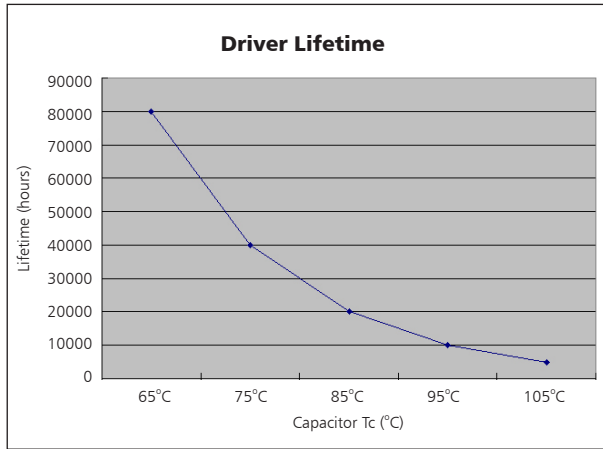

Temperature

- The testing is operated at 25°C
- The lifetime of capacitor, minimum of 5,000 hours if operated at 105°C, will be doubled whenever the temperature drops 10°C
- The highest withstand temperature of IC, MOS could be 120°C
- The highest withstand temperature of LED junction temperature is 150°C

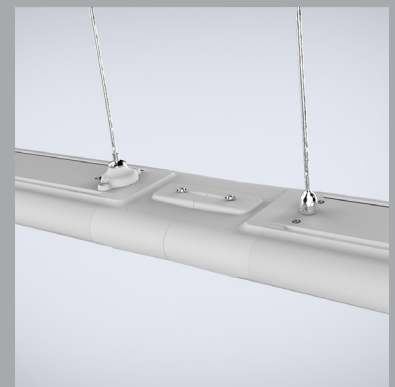
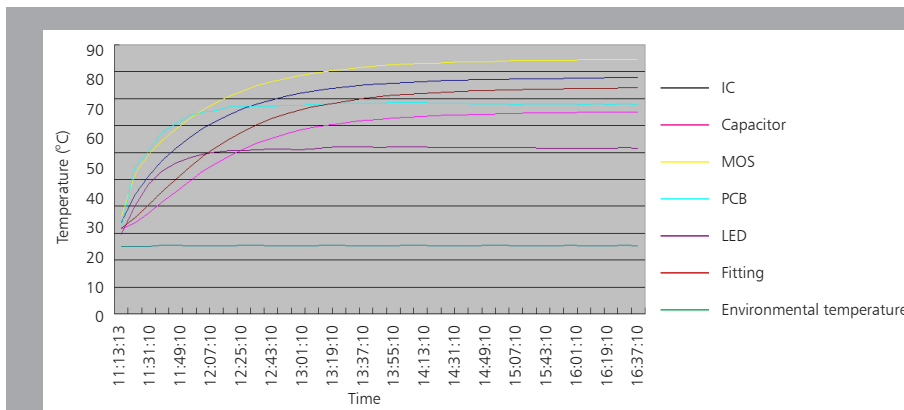

The driver lifespan is based on capacitor working temperature.

Suspend install

1. Fix the holders of suspending ropes on the ceiling.

SPEC.	A ±10
600mm	460mm
900mm	760mm
1200mm	1060mm

2. Keep the proper distance of the 2pcs suspending ropes as below table.

3. Fix the pedestal of suspending ropes on the lamp by screws.

4. Loosen the c flat-head screws on ends of fittings and fix the suspending accessories on the lamps.

5. Take down the 2pcs flat-head screws on the back of lamp, fix the suspending accessories on the lamp.

6. Remove the safety cover on the both sides of the batten by screwdriver

7. Lock the linkable bracket into end cap slots, and insert connector into lamp slots.

8. Link the two lamps together, fix the 2pcs screws on the linkable bracket and connect the power.

9. Settle the input wires properly and switch on.

L = BROWN
 N = BLUE
 PE = YELLOW-GREEN

Surface mount

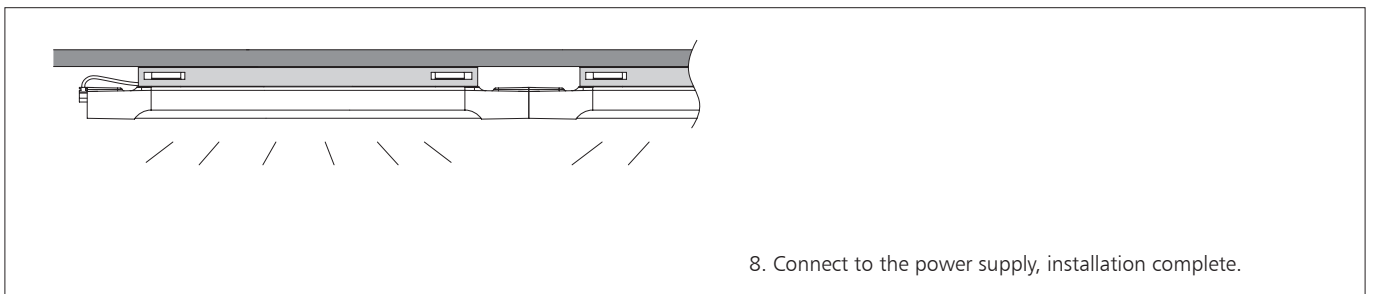
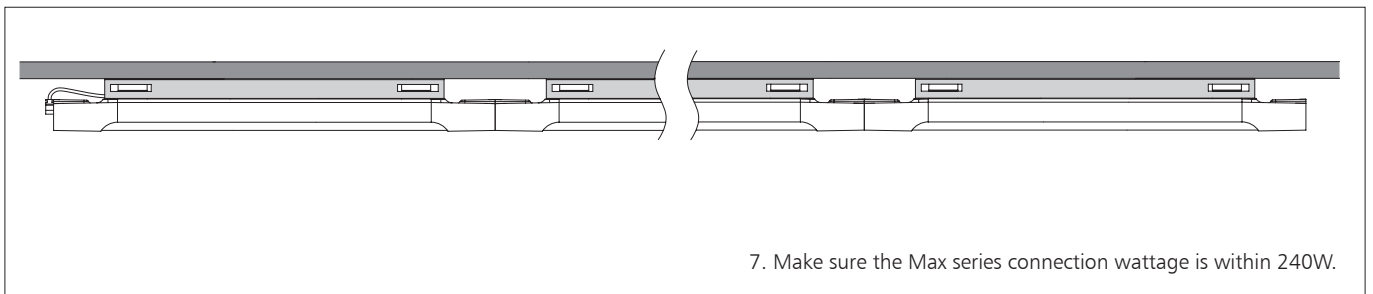
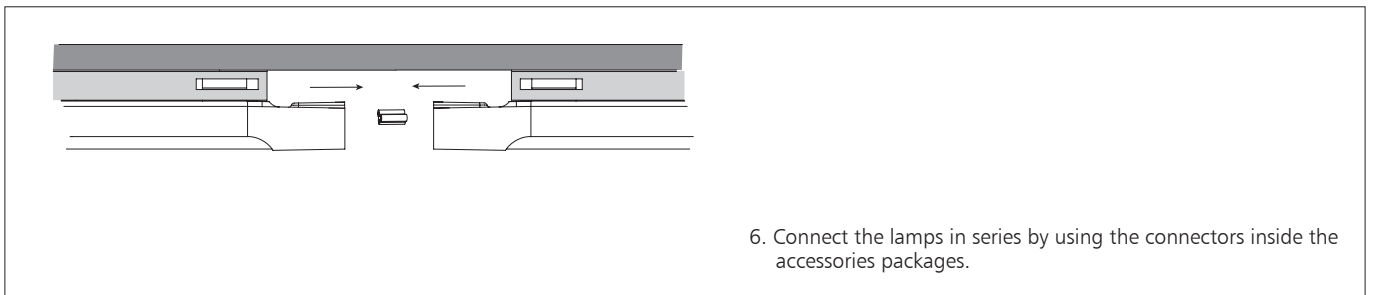
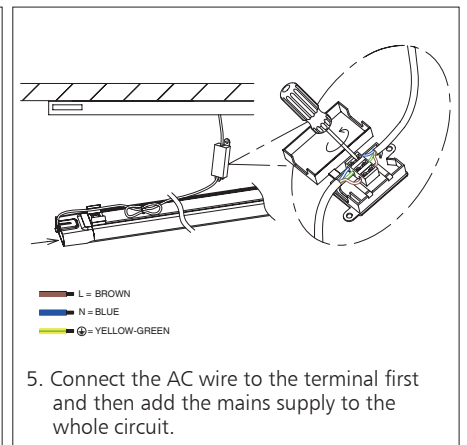
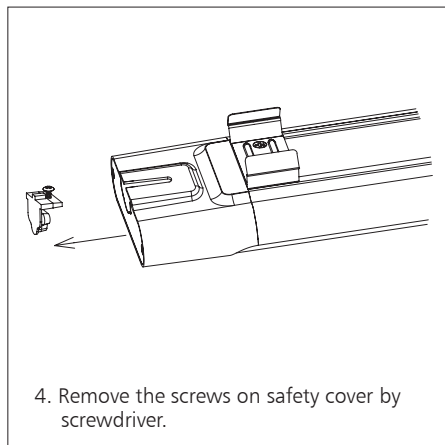
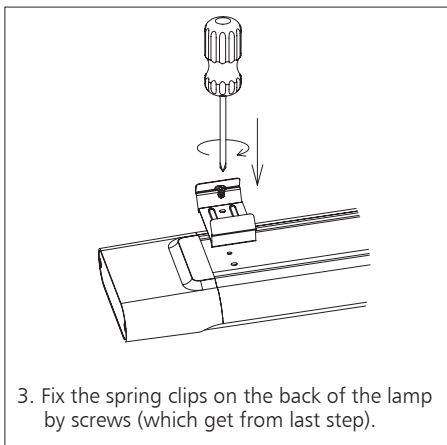
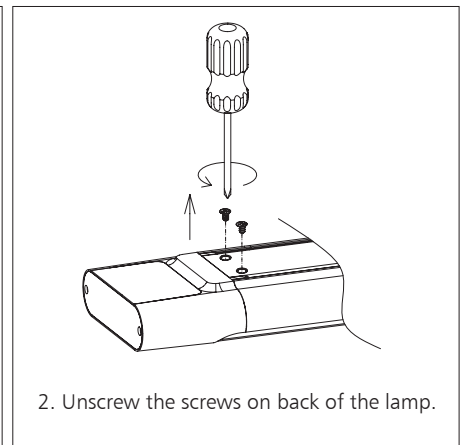
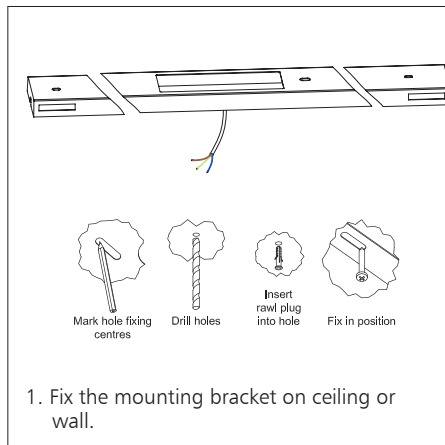
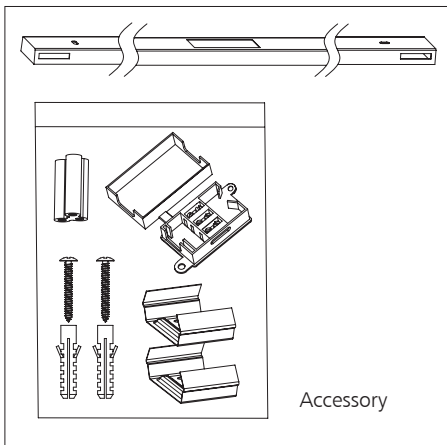

Packing information without accessories

	SIZE(CM)	N.W/pc (KGS)	G.W.(KGS)	Q'TY(PCs)
Carton	93.5*30.5*24	1.1	16.2	12

	CTNS	Q'TY(PCs)	VOLUME(CBM)
20" standard container	400	4800	28
40" standard container	800	9600	56

packing information with surface mounted accessories

	SIZE(CM)	N.W/pc (KGS)	G.W.(KGS)	Q'TY(PCs)
Carton	88.5*26*16.8	0.5	12	24

	CTNS	Q'TY(PCs)	VOLUME(CBM)
20" standard container	705	16920	28
40" standard container	1410	33840	56

packing information with suspending accessories

	SIZE(CM)	N.W/pc (KGS)	G.W.(KGS)	Q'TY(PCs)
Carton	93.5*30.5*24	1.18	17.2	12

	CTNS	Q'TY(PCs)	VOLUME(CBM)
20" standard container	400	4800	28
40" standard container	800	9600	56

