



Up-shine® Lighting



Technical Application
Guide for UP-SHINE
LED Double emitting
Batten

UP-DB15-0.6-20W

Introduction

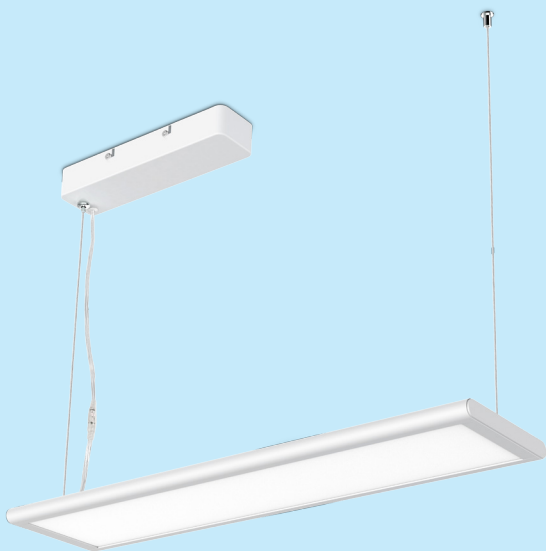

DB15 suspending led batten light is a double-emitting luminaire designed with 270° wide beam angle. Distribute 60% lumens downwards to satisfying the basic requirement for activities and 40% lumens upwards to creating a brilliant lighting atmosphere. The double-emitting batten is equipped with high brightness SMD LED in high color rendering and top quality LGP to provide extremely uniform lighting. Appearance design looks fashionable and elegant with unique round curved profile, this makes our DB15 ideal for decorative and illumination.

- Up to 80% energy saving compared to standard CFL
- Long lifetime of 40,000 hours
- Triac dim
- 270° wide beam angle
- CCT: 3000K 4000K 5000K 5700K
- No UV/IR light
- Environment friendly, without Mercury or any other hazardous substances

Application notes

- IP40 for indoor use only
- The lamp must be installed by professional electrician
- Ensure the power supply is switched off before fitting this product
- Do not touch the lamp when in use
- Keep away from hot steam and corrosive gas

Application Areas

Widely used in office, meeting room, hotel, school etc.

Certificate

CE RoHS



Product Information

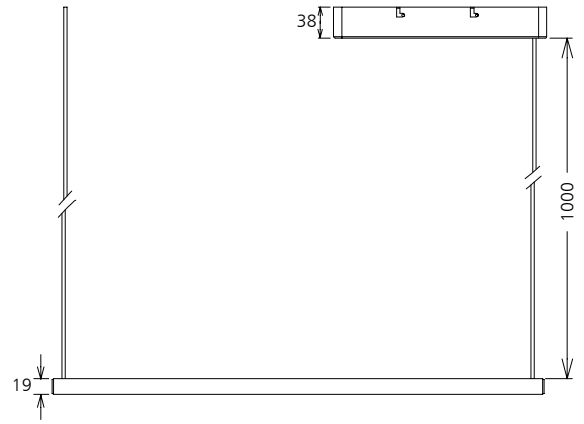
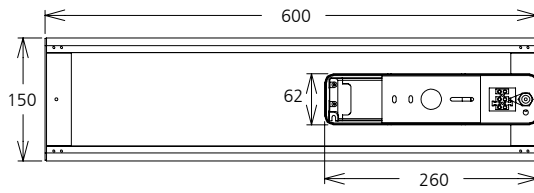

Technical Specifications

Model	Voltage	Power	Power Factor	Lumen (±5%)	Beam angle	CCT	Lifespan	CRI	Dimmable	Dimension
UP-DB15-0.6-20W	AC230V	20W	≥0.9	1380	270°	3000K	40000h	≥80	No	L600*W150*H19mm
UP-DB15-0.6-20W	AC230V	20W	≥0.9	1540	270°	4000K	40000h	≥80	No	L600*W150*H19mm
UP-DB15-0.6-20W	AC230V	20W	≥0.9	1440	270°	5000K	40000h	≥80	No	L600*W150*H19mm
UP-DB15-0.6-20W	AC230V	20W	≥0.9	1480	270°	5700K	40000h	≥80	No	L600*W150*H19mm
UP-DB15-0.6-20W-D	AC230V	20W	≥0.9	1340	270°	3000K	40000h	≥80	Yes	L600*W150*H19mm
UP-DB15-0.6-20W-D	AC230V	20W	≥0.9	1480	270°	4000K	40000h	≥80	Yes	L600*W150*H19mm
UP-DB15-0.6-20W-D	AC230V	20W	≥0.9	1380	270°	5000K	40000h	≥80	Yes	L600*W150*H19mm
UP-DB15-0.6-20W-D	AC230V	20W	≥0.9	1440	270°	5700K	40000h	≥80	Yes	L600*W150*H19mm

Driver data Sheet

Driver data	DIM	Main Power
Input rated Voltage	AC230V	AC230V
Frequency	50Hz	50Hz
Input Voltage	AC200-240V	AC200-240V
Efficiency	83%	≥85%
Total load Wattage	20W±5%	20W±5%
Power Factor	≥0.9	≥0.9
Rated input current	≤0.12A	≤0.12A
Full load output Voltage	DC23-40V	DC24-40V
Rated output current	500mA	500mA
Output current range	500mA±5%	500mA±5%
Power tolerance	±5%	±5%
Current output tolerance	±5%	±5%
Dimming range	8%-100%	—
Dimmer	Triac dimmers	—
Short circuit protection	PASS	PASS
Over voltage protection	PASS	PASS
Over temperature protection	PASS	PASS
THD	<20%	<20%
Withstand voltage	AC1500V	AC1500V

Fixture Compatibility

Rated Wattage	Electrical Classification	Ingress Protection	Operating Temp	Operating Humidity	Storage Temp
20W	I	IP40	-20°C~45°C	0~90%	-20°C~65°C

Spectral Distribution

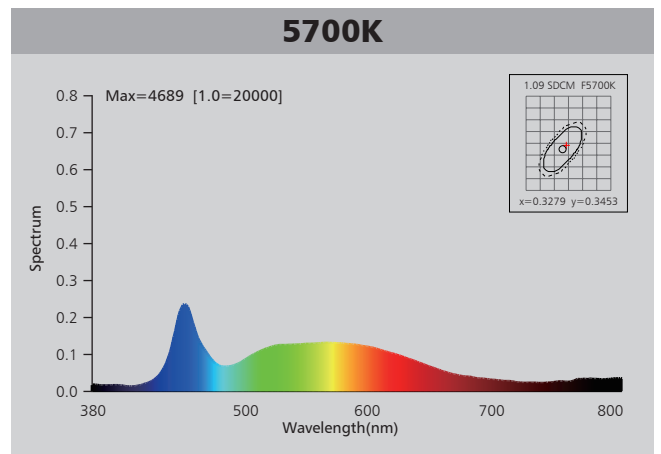
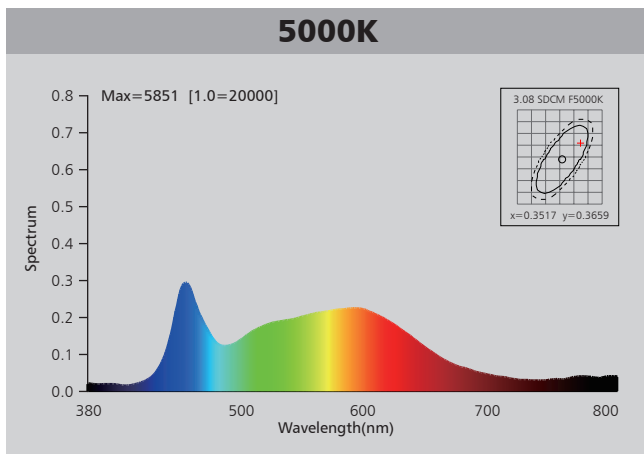
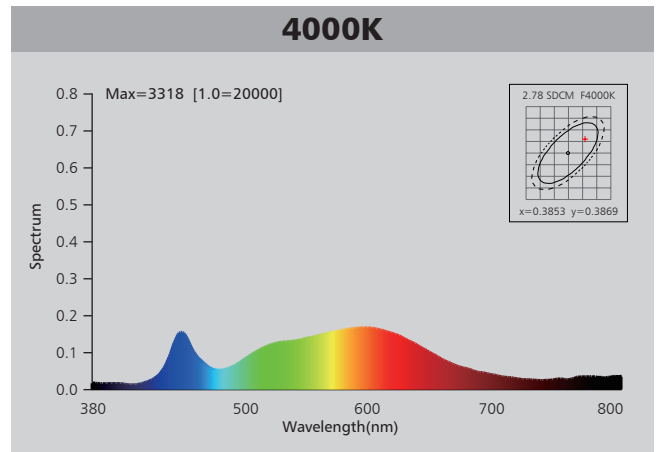
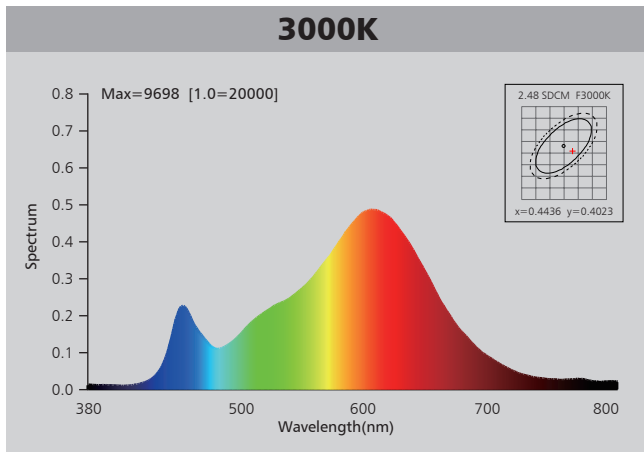

Photometric Diagram

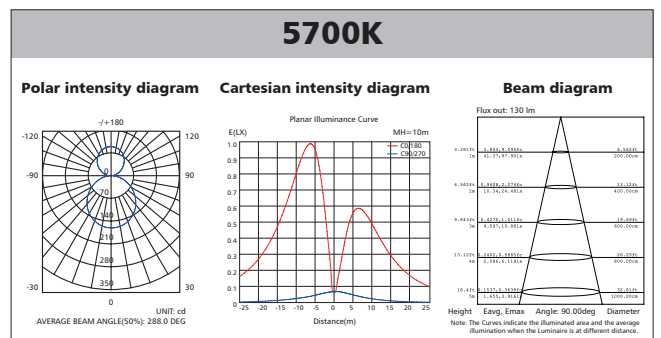
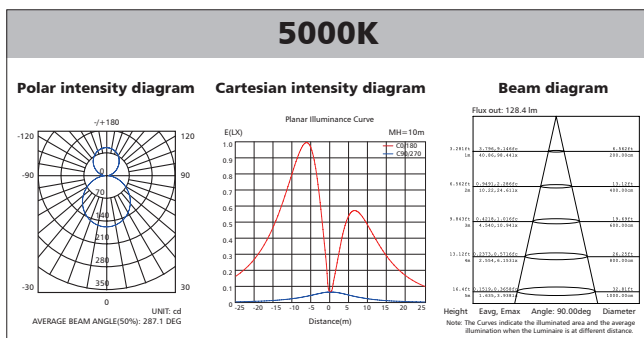
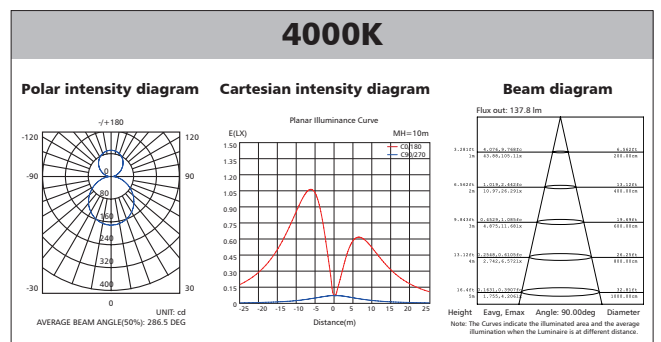
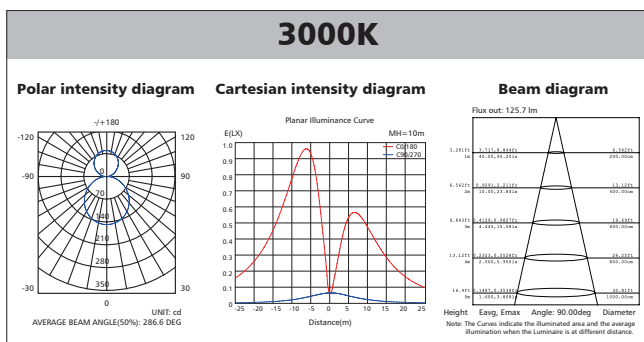

Polar Diagram Comparison

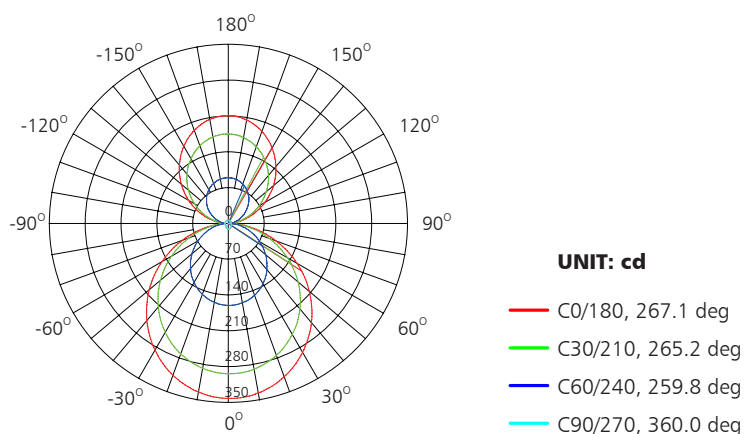

AVERAGE BEAM ANGLE (50%): 288.0DEG



Driver lifetime & LED light decay rate

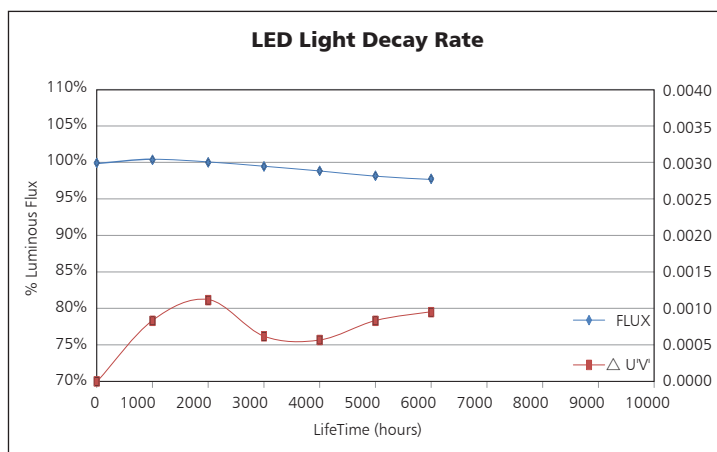
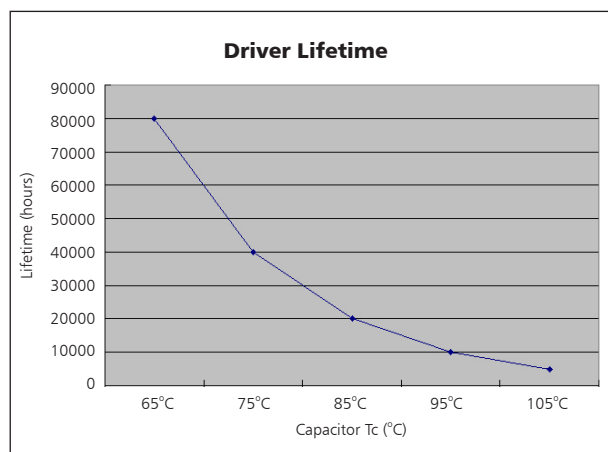

Temperature

- The testing is operated at 25°C
- The lifetime of capacitor, minimum of 5,000 hours if operated at 105°C, will be doubled whenever the temperature drops 10°C
- The highest withstand temperature of IC, MOS could be 120°C
- The highest withstand temperature of LED junction temperature is 150°C

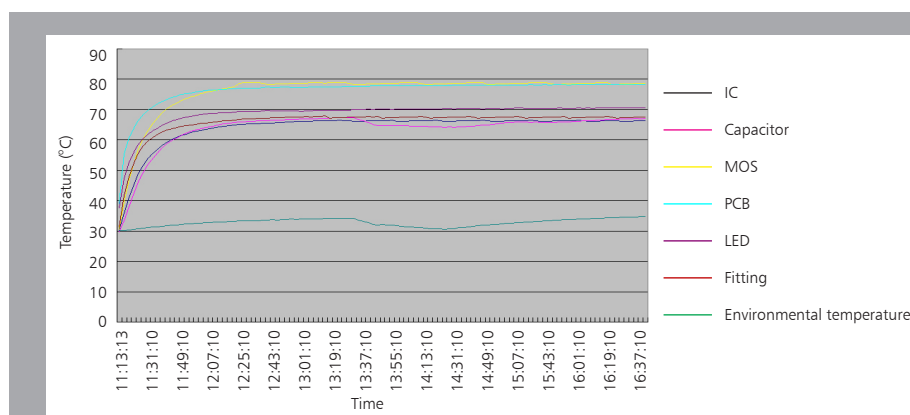

The driver lifespan is based on capacitor working temperature.

Installation 1

STEP 1

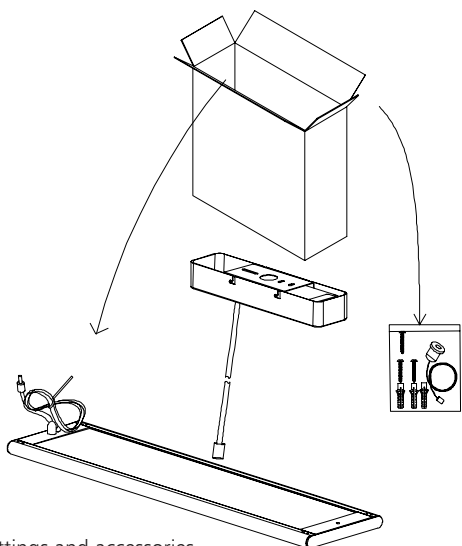

Take out the fittings and accessories.

STEP 2

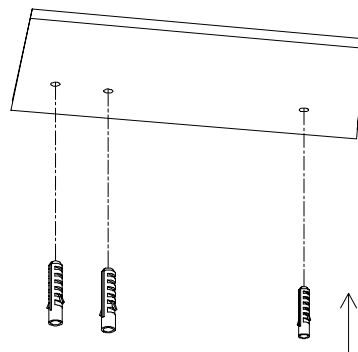

Knock the plastic anchor into ceiling.

STEP 3

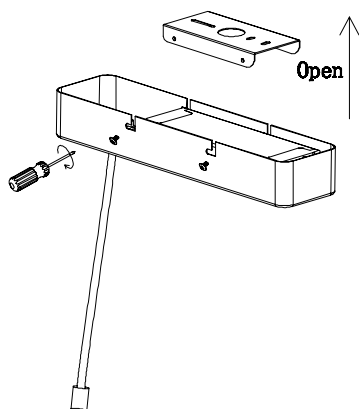

Take the bracket out from driver box.

STEP 4

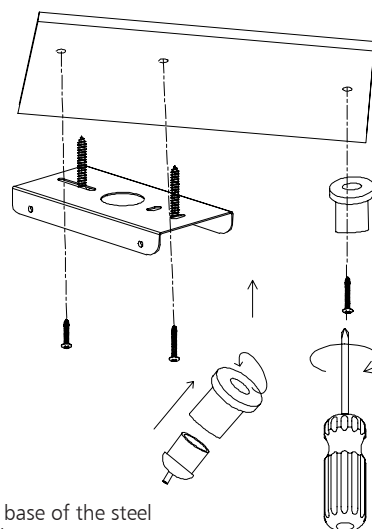

Fix the bracket and base of the steel wire on the ceiling by screws.

STEP 5

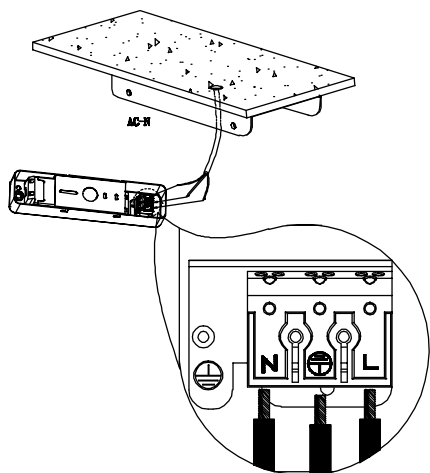

Power off. Connect the L/N/G wires to the connection terminals in the driver box.

STEP 6

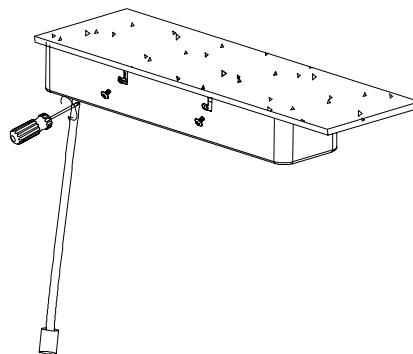

Attach the driver box to the bracket and fix it by screws.

STEP 7

Fasten the steel wire base onto the latten with screws.

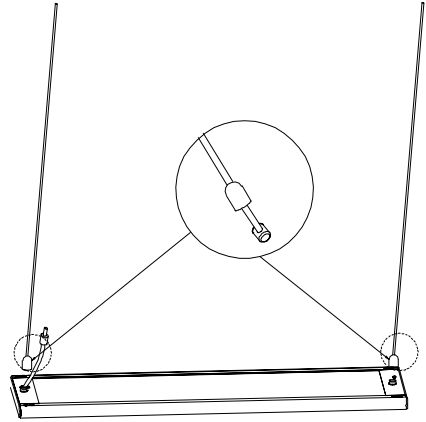
STEP 8

Connect the steel wires to the base until it's tightened.

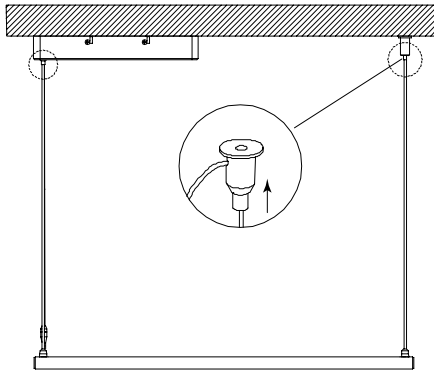
STEP 9

Connect the other end of steel wire to the base on the ceiling.

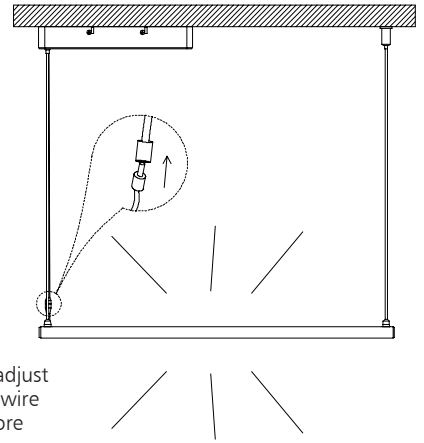
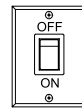
STEP 10

Connect the DC plug, adjust the length of hanging wire to proper height. Restore the power and switch on.

Packaging Information

	SIZE(CM)	N.W/pc (KGS)	G.W.(KGS)	QTY(PCS)
Carton	95*43.5*23	2.24	14.5	6

	CTNS	QTY(PCS)	VOLUME(CBM)
20" standard container	291	1746	28
40" standard container	582	3492	56

