



UPSHINE[®]



Technical Application
Guide for UP-SHINE
LED Linear

UP-DB09-600-12W

Introduction

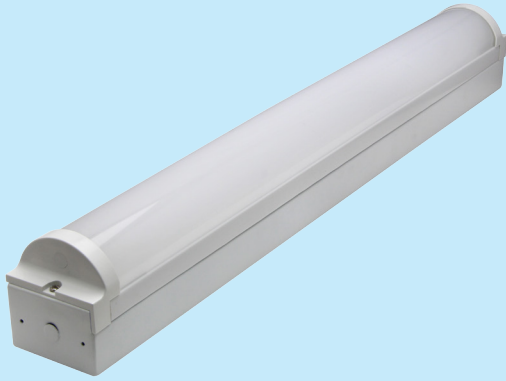

DB09 LED Linear is mainly designed for Oceania and European market, 2835 high lumen SMD LED chip been used to achieve 105lm/W efficiency. IP54 waterproof structural design, ideal replacement for damp location. Elegant design with 3 types of installation: suspended, surface mounted and recessed, suitable for meeting room, office, school, hospital etc commercial lighting applications.

- Aluminum components generate a rust-free product for less maintenance
- PC Diffuser
- Up to 70% energy saving compared to standard CFL
- Environment friendly, without Mercury or any other hazardous substances

Application notes

- IP54 for indoor use only
- The lamp must be installed by professional electrician
- Ensure the power supply is switched off before fitting this product
- Do not touch the lamp when in use
- Keep away from hot steam and corrosive gas

Application Areas

Widely used in office, meeting room, hotel, school etc.

Certificate

CE RoHS SAA



Product Information

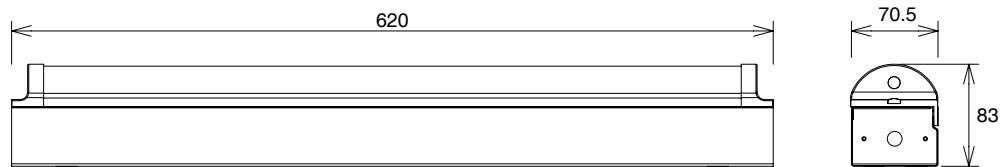

Technical Specifications

Model	Voltage	Power	Power Factor	Lumen (±5%)	Beam angle	CCT	Lifespan	CRI	Dimmable	Dimension
UP-DB09-600-12W	AC100-277V	12W	≥0.9	1200	120°	3000K	40000h	≥80	No	L620*W70.5*H83mm
UP-DB09-600-12W	AC100-277V	12W	≥0.9	1260	120°	4000K	40000h	≥80	No	L620*W70.5*H83mm
UP-DB09-600-12W	AC100-277V	12W	≥0.9	1240	120°	5000K	40000h	≥80	No	L620*W70.5*H83mm
UP-DB09-600-12W	AC100-277V	12W	≥0.9	1220	120°	5700K	40000h	≥80	No	L620*W70.5*H83mm

Driver data Sheet

Driver data	Main Power
Input rated Voltage	AC100-277V
Frequency	50/60Hz
Input Voltage	AC90-305V
Efficiency	≥85%
Total load Wattage	12W±1W
Power Factor	≥0.9
Rated input current	≤0.16A
Full load output Voltage	60-75V
Rated output current	150mA
Output current range	150mA±5%
Power tolerance	±5%
Current output tolerance	±5%
Short circuit protection	PASS
Over voltage protection	PASS
Over temperature protection	PASS
THD	<25% AC230V
Withstand voltage	AC1500V

Fixture Compatibility

Rated Wattage	Electrical Classification	Ingress Protection	Operating Temp	Operating Humidity	Storage Temp
12W	I	IP54	-20°C~45°C	0~90%	-20°C~65°C

Spectral Distribution

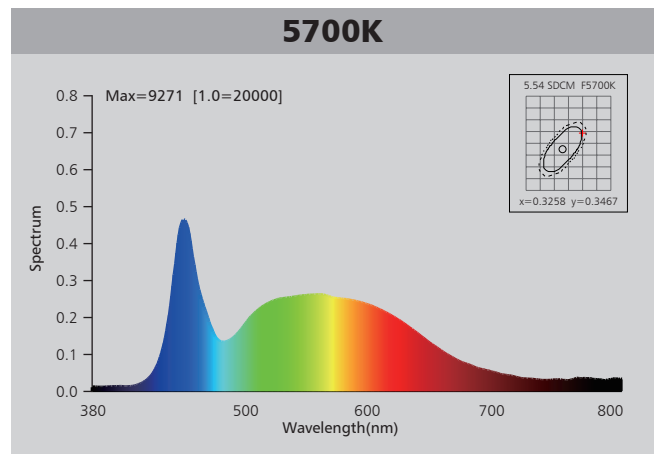
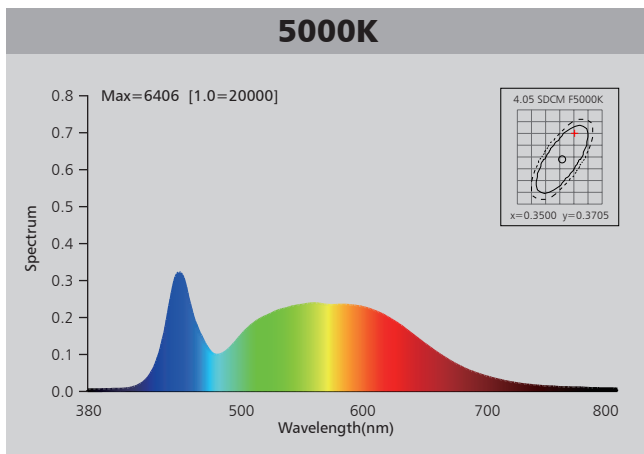
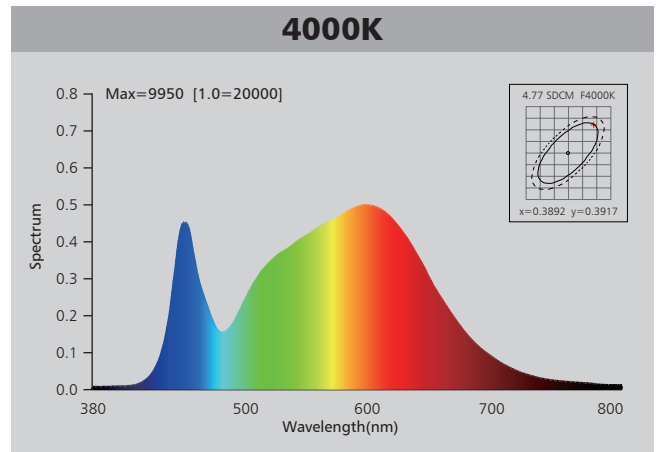
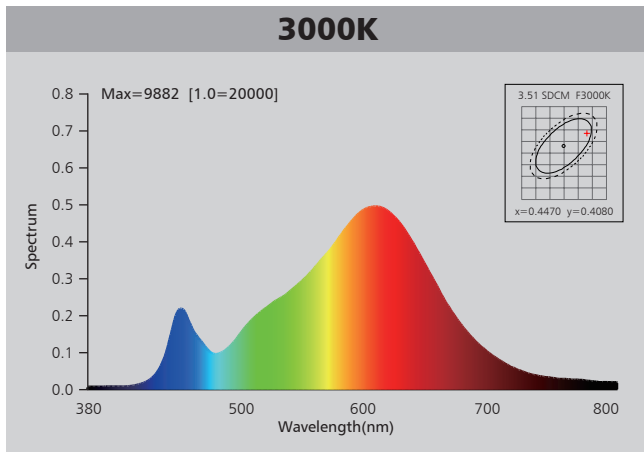

Photometric Diagram

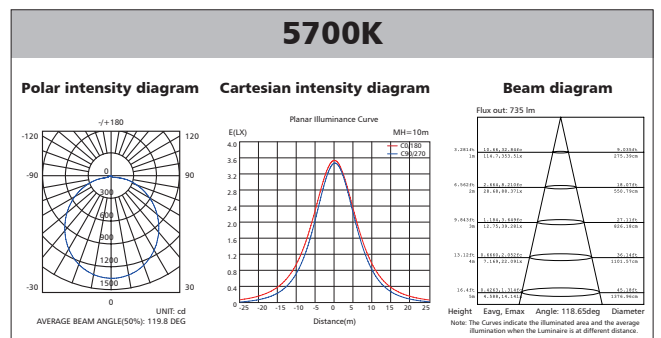
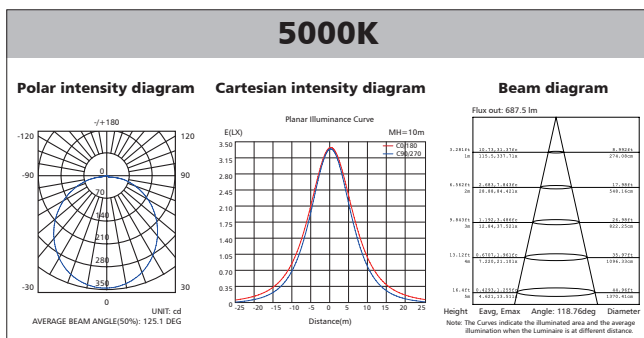
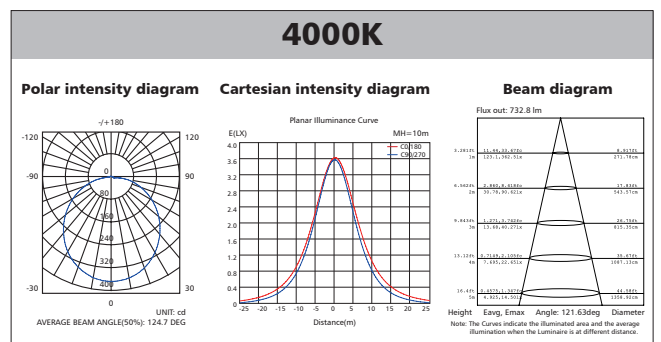
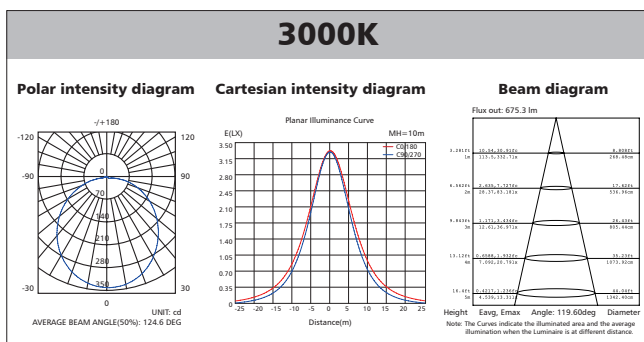

Polar Diagram Comparison

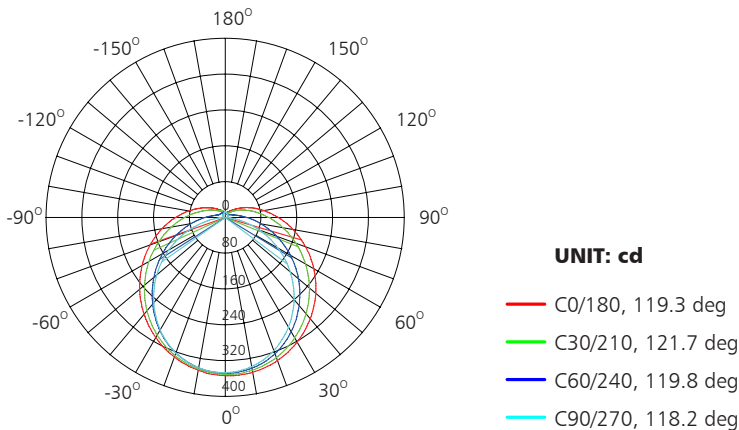

AVERAGE BEAM ANGLE (50%): 122.5DEG

Driver lifetime & LED light decay rate

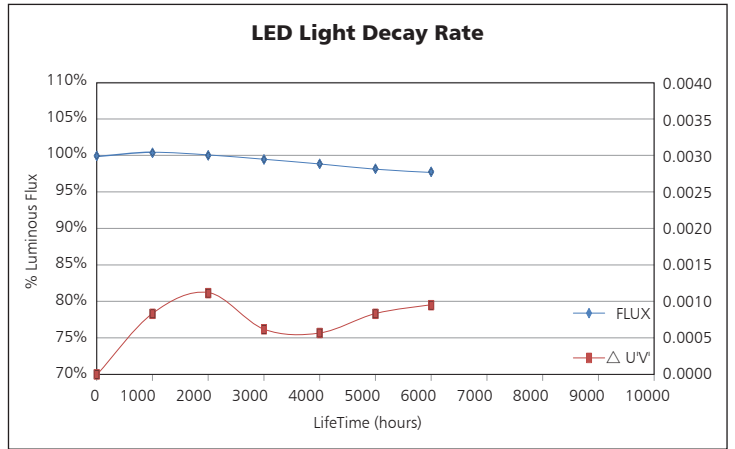
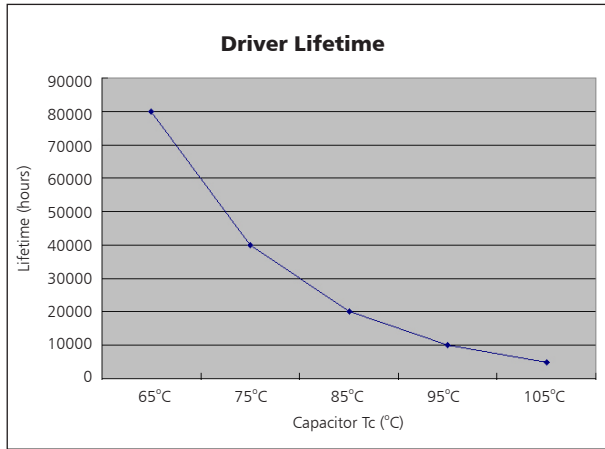

Temperature

- The testing is operated at 25°C
- The lifetime of capacitor, minimum of 5,000 hours if operated at 105°C, will be doubled whenever the temperature drops 10°C
- The highest withstand temperature of IC, MOS could be 120°C
- The highest withstand temperature of LED junction temperature is 150°C

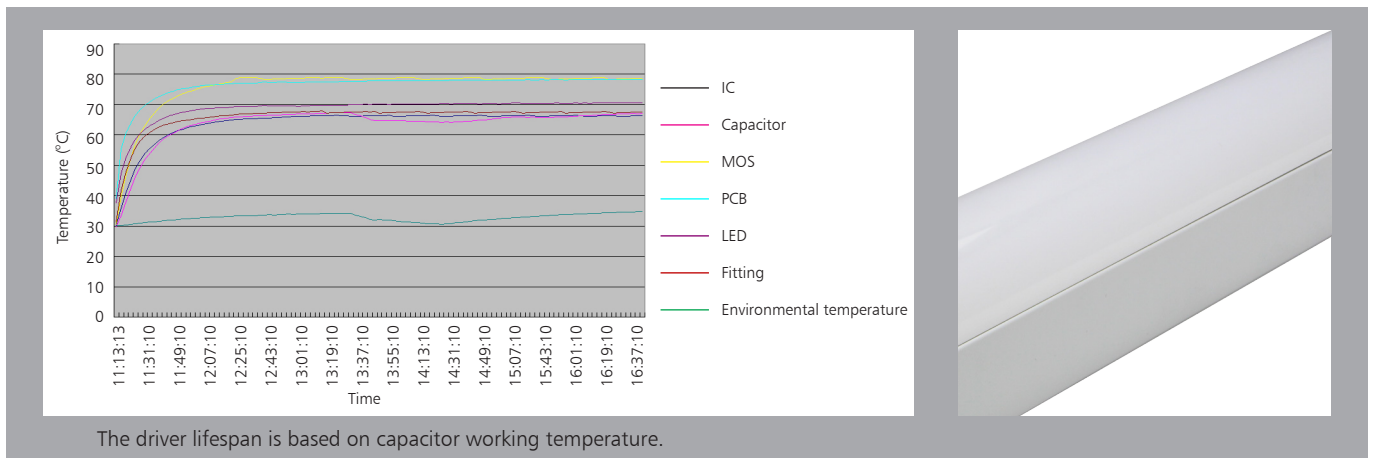

Surface mount

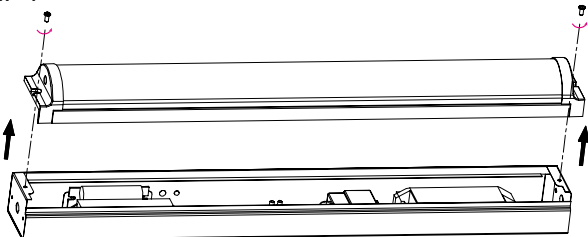
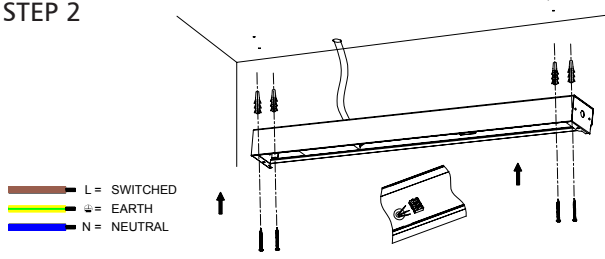
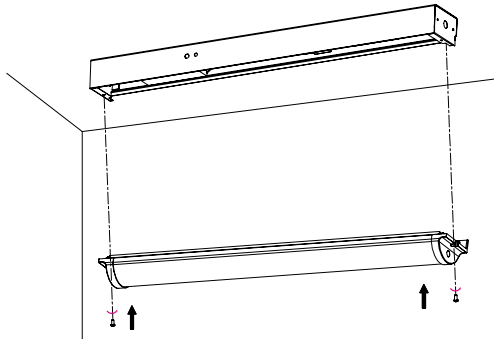
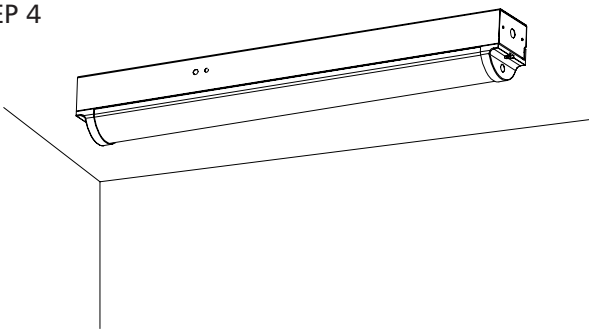
<p>STEP 1</p>  <p>1.Remove the diffuser and cover as show in figure 1.</p>	<p>STEP 2</p>  <p>2.Determine the mounting location and cable entry direction, put the batten against the ceiling and mark the position of the mounting screw holes. Fix lamp base into ceiling with plastic anchor and screw as shown in figure 2.Route the mains cable through the cable entry hole, connect and terminate wires to the terminal block.</p>
<p>STEP 3</p>  <p>3.Refit the cover and diffuser to base.</p>	<p>STEP 4</p>  <p>4.Restore power and check for correct operation.</p>

wall mount

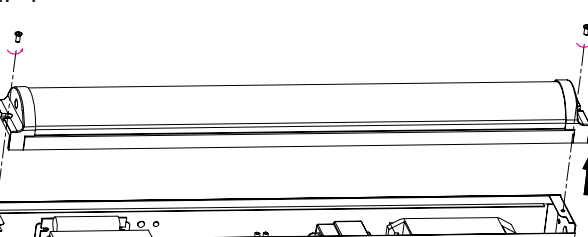
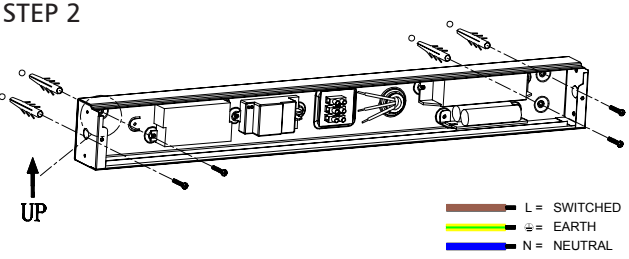
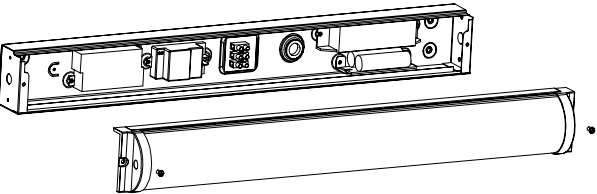
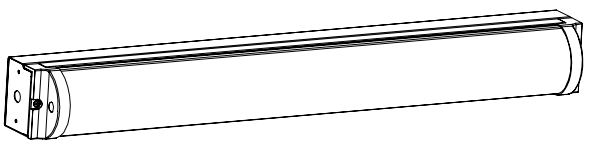
<p>STEP 1</p>  <p>1.Remove the diffuser and cover as show in figure 1.</p>	<p>STEP 2</p>  <p>2.Determine the mounting location and cable entry direction, put the batten against the ceiling and mark the position of the mounting screw holes. Secure the batten to the ceiling with screw. Route the mains cable through the cable entry hole, connect and terminate wires to the terminal block.</p>
<p>STEP 3</p>  <p>3.Refit the cover and diffuser to base.</p>	<p>STEP 4</p>  <p>4.Restore power and check for correct operation.</p>

Suspend install

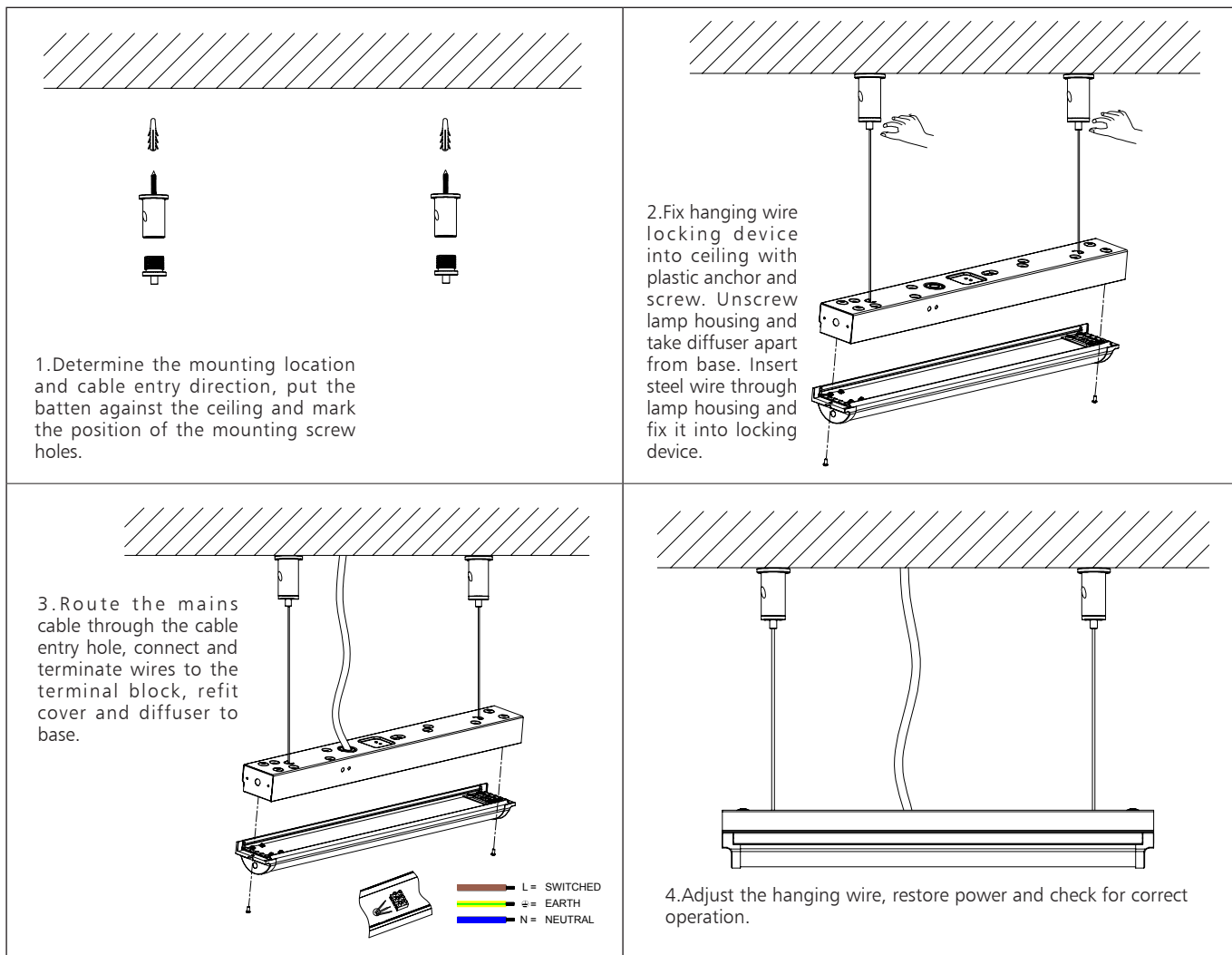

Packaging Information

	SIZE(CM)	N.W/pc (KGS)	G.W.(KGS)	Q'TY(PCS)
Carton	65*36.5*33	1.5	20	12

	CTNS	Q'TY(PCS)	VOLUME(CBM)
20" standard container	352	4224	28
40" standard container	704	8448	56

