



UPSHINE®



Technical Application
Guide for UP-SHINE
LED Pendant Linear
UP-DB08-1500-45W

Introduction

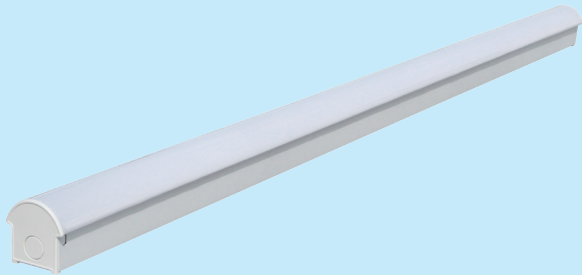

The design of batten realizes low cost, simple construction and superior capability, milky PC diffuser achieves anti-glare and high light transmittance. It is made of high lumen 2835SMD led chip, energy saving, instant start, no flickering, no noise & UV/IR radiation, environmental friendly without Mercury or any other hazardous substances. It is a high efficient and low cost product with quite large potential market. Ideal replacement for various applications such as workshop, warehouse, exhibition hall, factory, shop, supermarket etc.

- Aluminum components generate a rust-free product for less maintenance
- Up to 70% energy saving compared to standard CFL
- Environment friendly, without Mercury or any other hazardous substances

Application notes

- IP20 for indoor use only
- The lamp must be installed by professional electrician
- Ensure the power supply is switched off before fitting this product
- Do not touch the lamp when in use
- Keep away from hot steam and corrosive gas

Application Areas

Widely used in office, meeting room, hotel, school etc.

Certificate

CE RoHS SAA



Product Information

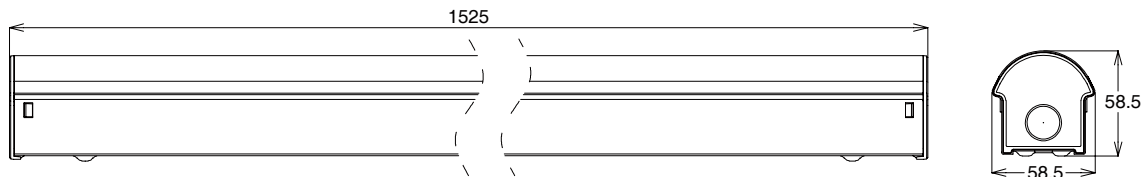

Technical Specifications

Model	Voltage	Power	Power Factor	Lumen (±5%)	Beam angle	CCT	Lifespan	CRI	Dimmable	Dimension
UP-DB08-1500-45W	AC100-277V	45W	≥0.9	4460	120°	3000K	40000h	≥80	No	L1525*W58.5*H58.5mm
UP-DB08-1500-45W	AC100-277V	45W	≥0.9	4860	120°	4000K	40000h	≥80	No	L1525*W58.5*H58.5mm
UP-DB08-1500-45W	AC100-277V	45W	≥0.9	4590	120°	5000K	40000h	≥80	No	L1525*W58.5*H58.5mm
UP-DB08-1500-45W	AC100-277V	45W	≥0.9	4500	120°	5700K	40000h	≥80	No	L1525*W58.5*H58.5mm

Driver data Sheet

Driver data	Main Power
Input rated Voltage	AC100-277V
Frequency	50/60Hz
Input Voltage	AC90-305V
Efficiency	≥88%
No load wattage	≤0.5W
Total load Wattage	45W±5%
Power Factor	≥0.9
Rated input current	≤0.5A
Full load output Voltage	60-75V
Rated output current	620mA
Output current range	620mA±5%
Power tolerance	±5%
Current output tolerance	±5%
Short circuit protection	PASS
Over voltage protection	PASS
Over temperature protection	PASS
THD	<18%
Withstand voltage	AC1500V

Fixture Compatibility

Rated Wattage	Electrical Classification	Ingress Protection	Operating Temp	Operating Humidity	Storage Temp
45W	I	IP20	-20°C~45°C	0~90%	-20°C~65°C

Spectral Distribution

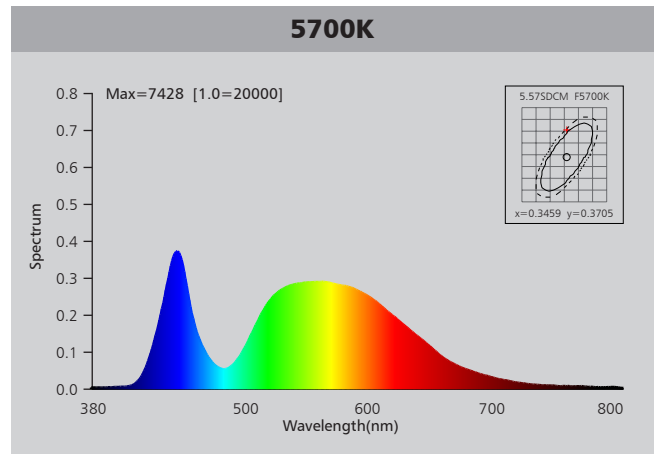
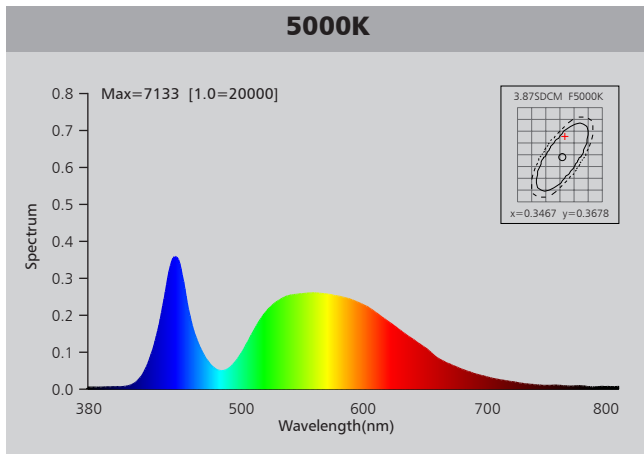
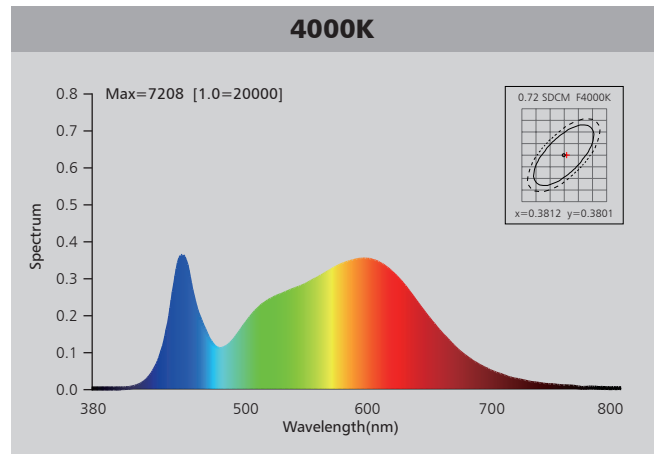
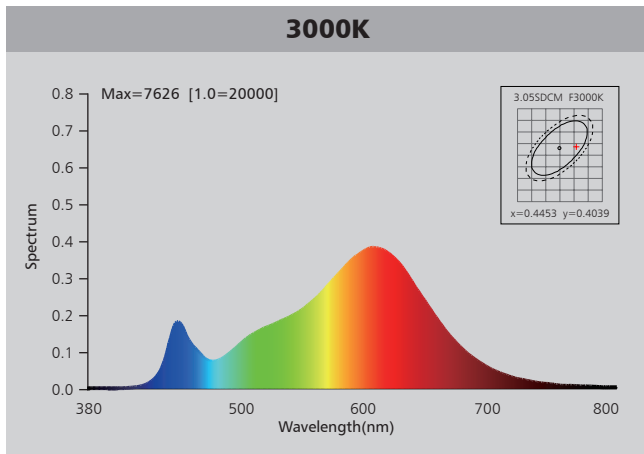

Photometric Diagram

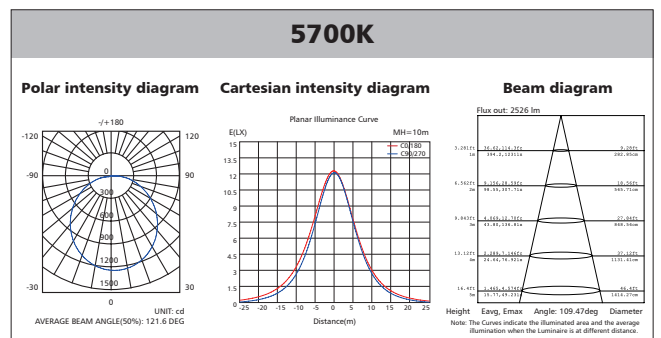
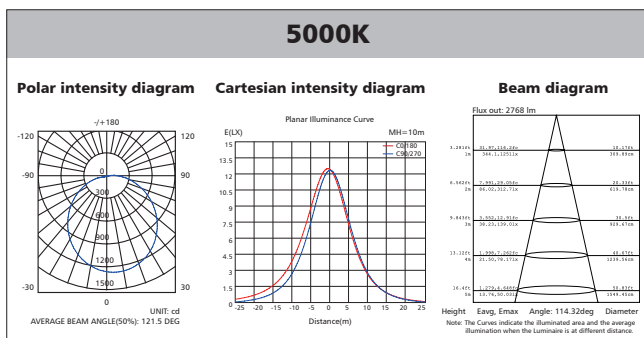
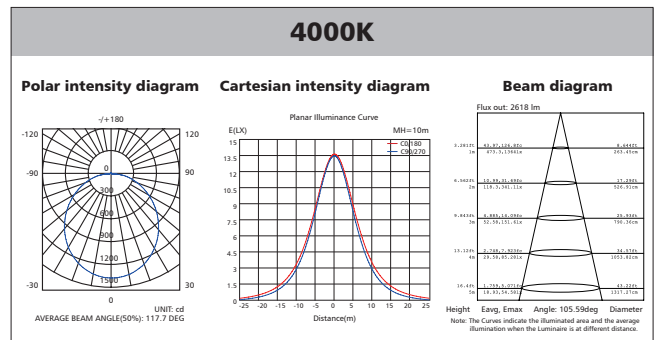
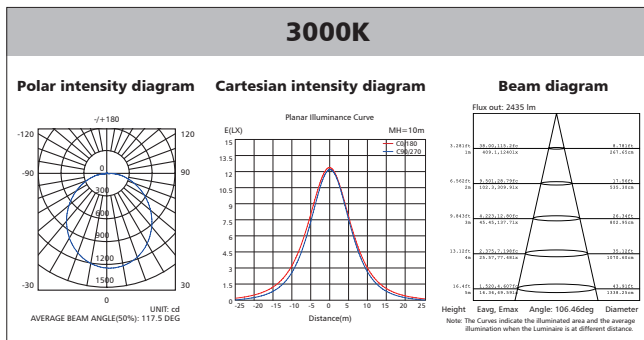

Polar Diagram Comparison

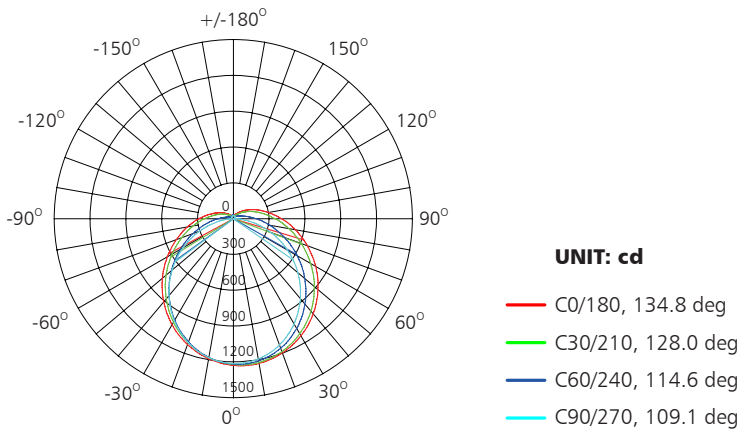

AVERAGE BEAM ANGLE (50%): 121.6DEG



Driver lifetime & LED light decay rate

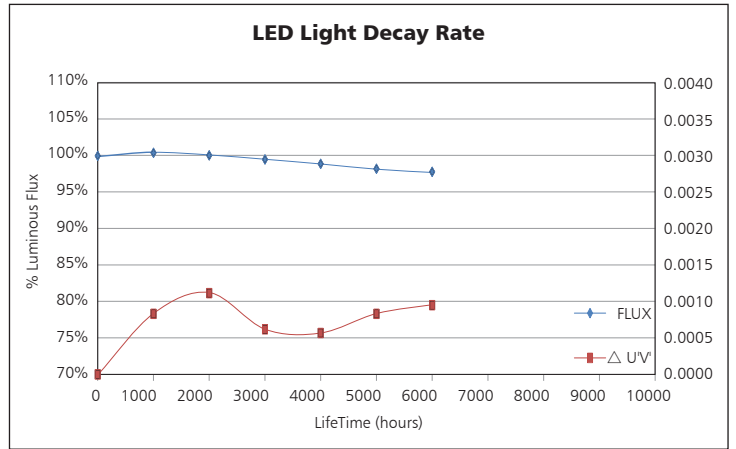
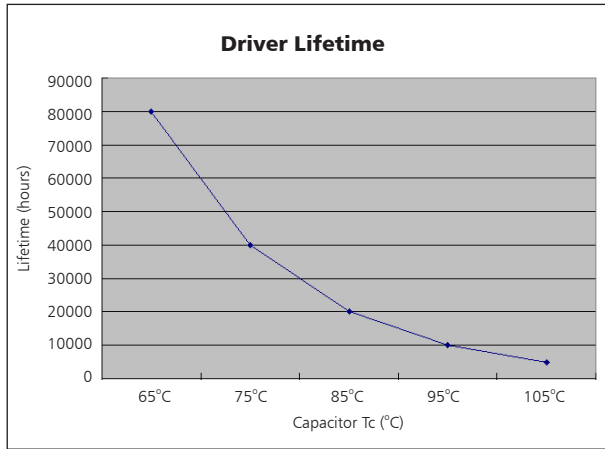

Temperature

- The testing is operated at 25°C
- The lifetime of capacitor, minimum of 5,000 hours if operated at 105°C, will be doubled whenever the temperature drops 10°C
- The highest withstand temperature of IC, MOS could be 120°C
- The highest withstand temperature of LED junction temperature is 150°C

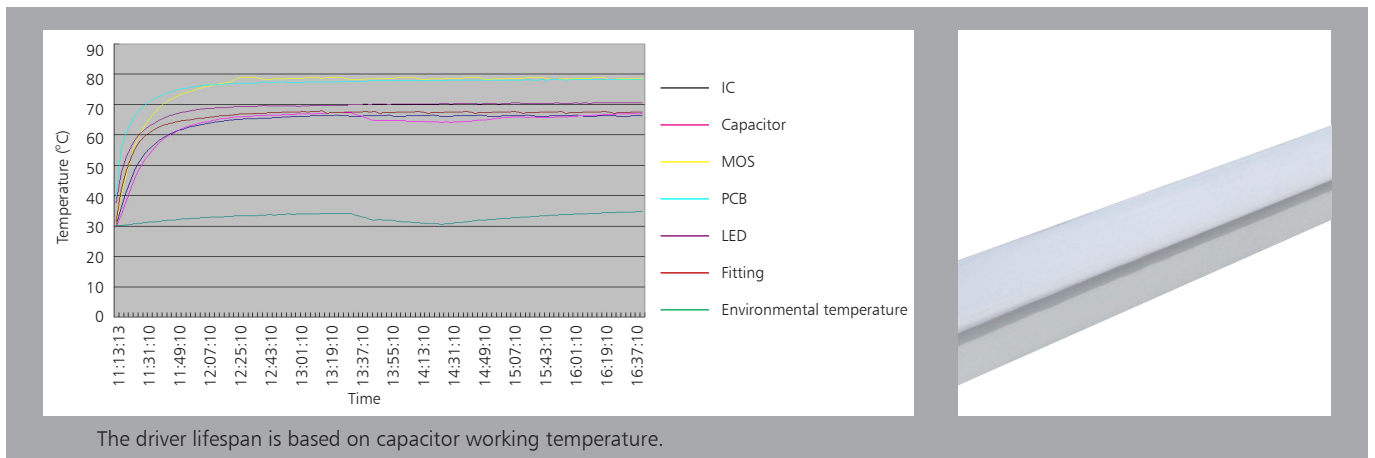

Installation 1

STEP 1

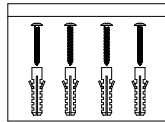
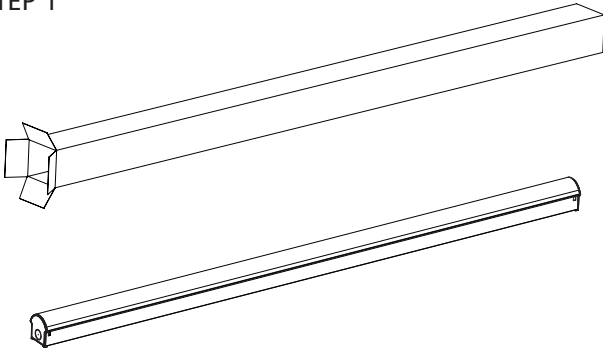

Open the packing and take out the lamp

STEP 2

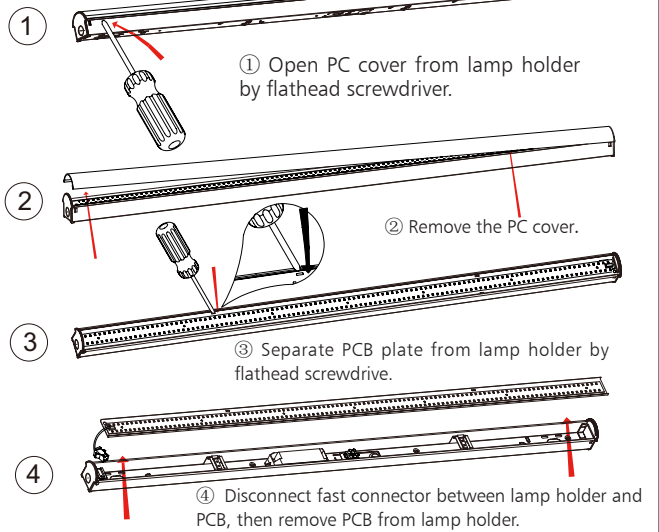

STEP 3

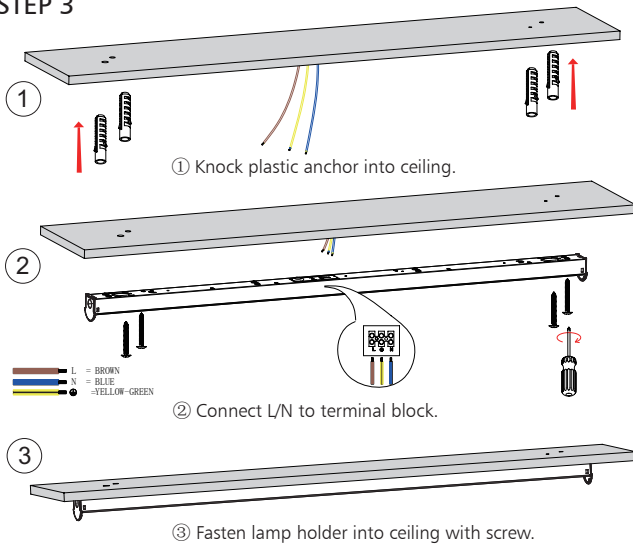

STEP 4

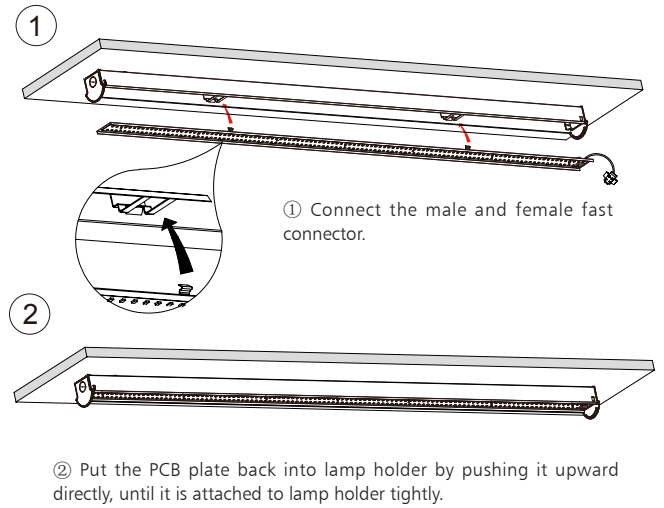

STEP 5

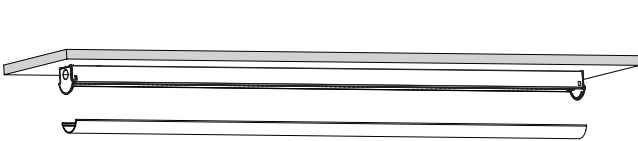

Pushing PC cover back to lamp holder by hands, until it is firmly fixed.

STEP 6

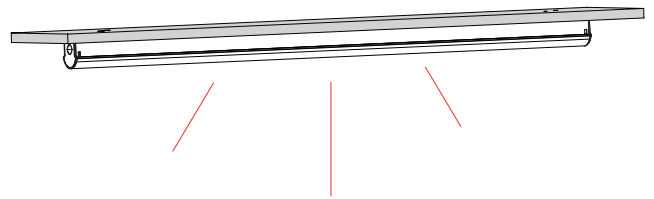

Restore mains power and switch on for correct operation.

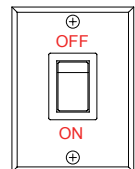

Installation 2

STEP 1

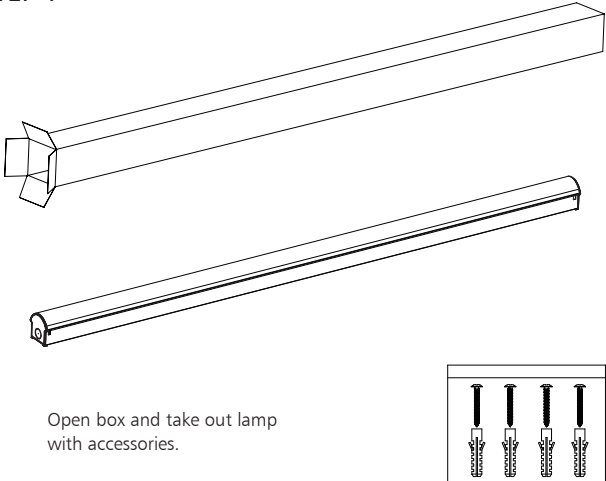

Open box and take out lamp with accessories.

STEP 2

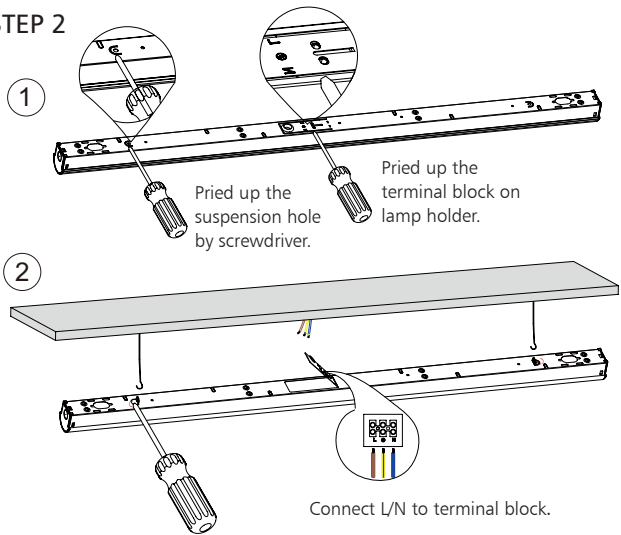

① Pried up the suspension hole by screwdriver.

② Pried up the terminal block on lamp holder.

Connect L/N to terminal block.

STEP 3

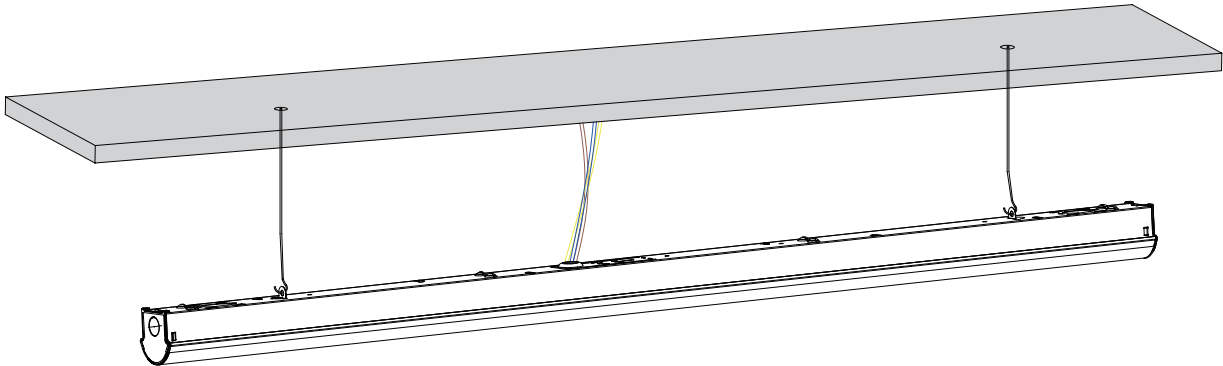

Hang fixture to ceiling with hanging wire.

Packaging Information

	SIZE(CM)	N.W/pc (KGS)	G.W.(KGS)	Q'TY(PCS)
Carton	159.5*21.5*15.5	1.9	15	6

	CTNS	Q'TY(PCS)	VOLUME(CBM)
20" standard container	517	3102	28
40" standard container	1034	6204	56

