



UPSHINE[®]



Technical Application
Guide for UP-SHINE
LED Pendant Linear
UP-DB08-1200-42W-S

Introduction



The design of batten realizes low cost, simple construction and superior capability, milky PC diffuser achieves anti-glare and high light transmittance. It is made of high lumen 2835SMD led chip, energy saving, instant start, no flickering, no noise & UV/IR radiation, environmental friendly without Mercury or any other hazardous substances. It is a high efficient and low cost product with quite large potential market. Ideal replacement led batten for various applications such as parking lot, aisle, warehouse, underground passage, workshop etc.

- Aluminum components generate a rust-free product for less maintenance
- Up to 70% energy saving compared to standard CFL
- Environment friendly, without Mercury or any other hazardous substances

Microwave Sensor

Detection area:

- ◆ 140 degree wide detective beam angle with 5~7 meters distance.

Working pattern:

- ◆ In any given lighting condition, the light switches on automatically when presence detected.
- ◆ After presence left, light will continuously work within time-delay (60 seconds), then switch off automatically.
- ◆ After presence left, any movement detected within time-delay (60 seconds), the light will continuously work for another hold time (60 seconds), then switch off until next movement detected.
- ◆ Hold time: 60S

Application Areas

Widely used in indoor areas such as parking lot, aisle, warehouse, underground passage, workshop etc.

Certificate

CE RoHS SAA



Product Information

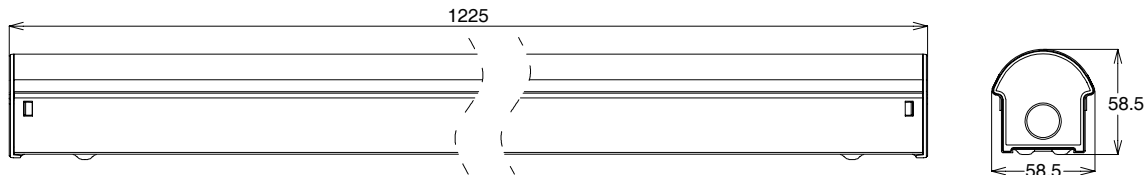

Technical Specifications

Model	Voltage	Power	Power Factor	Lumen (±5%)	Beam angle	CCT	Lifespan	CRI	Dimmable	Dimension
UP-DB08-1200-42W-S	AC230V	42W	≥0.9	3760	120°	3000K	40000h	≥80	No	L1225*W58.5*H58.5mm
UP-DB08-1200-42W-S	AC230V	42W	≥0.9	3960	120°	4000K	40000h	≥80	No	L1225*W58.5*H58.5mm
UP-DB08-1200-42W-S	AC230V	42W	≥0.9	3880	120°	5000K	40000h	≥80	No	L1225*W58.5*H58.5mm
UP-DB08-1200-42W-S	AC230V	42W	≥0.9	3800	120°	5700K	40000h	≥80	No	L1225*W58.5*H58.5mm

Driver data Sheet

Driver data	Sensor	Main Power
Input rated Voltage	AC230V	AC230V
Frequency	50Hz	50Hz
Input Voltage	AC200-240V	AC200-240V
Efficiency	—	≥85%
No load wattage	—	≤0.5W
Total load Wattage	2W±0.5W	40W±5%
Power Factor	—	≥0.93
Rated input current	≤0.02A	≤0.2A
Full load output Voltage	—	60-75V
Rated output current	—	560mA
Output current range	—	560mA±5%
Power tolerance	—	±5%
Current output tolerance	—	±5%
Hold time	60S	—
Detection distance	5-7m	—
Short circuit protection	—	PASS
Over voltage protection	—	PASS
Over temperature protection	—	—
THD	—	≤20%
Withstand voltage	—	AC1500V

Fixture Compatibility

Rated Wattage	Electrical Classification	Ingress Protection	Operating Temp	Operating Humidity	Storage Temp
42W	I	IP20	-20°C~45°C	0~90%	-20°C~65°C

Spectral Distribution

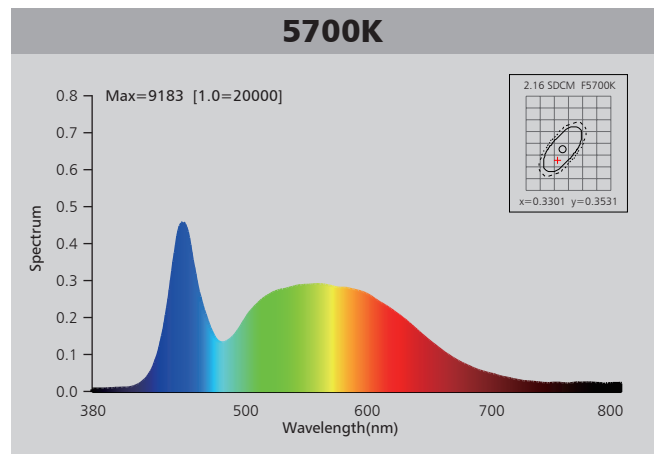
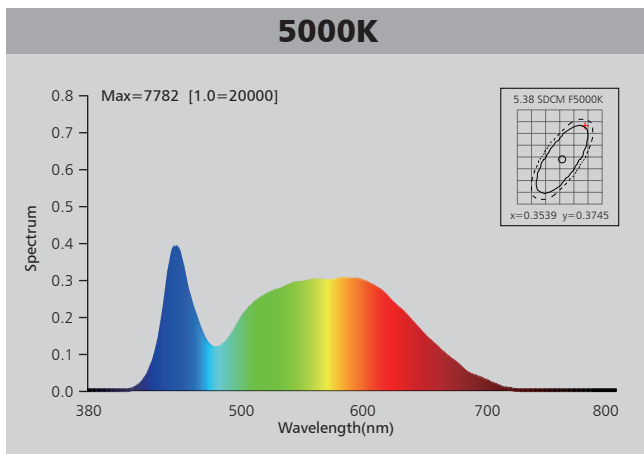
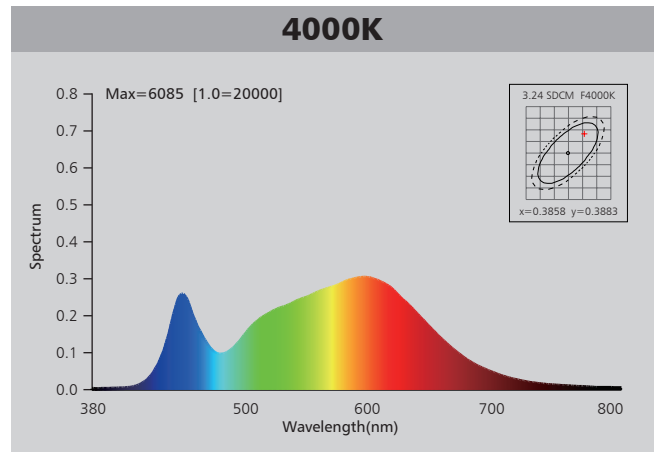
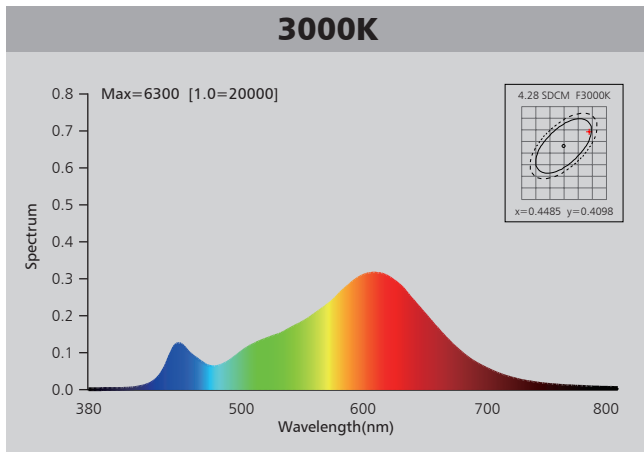

Photometric Diagram

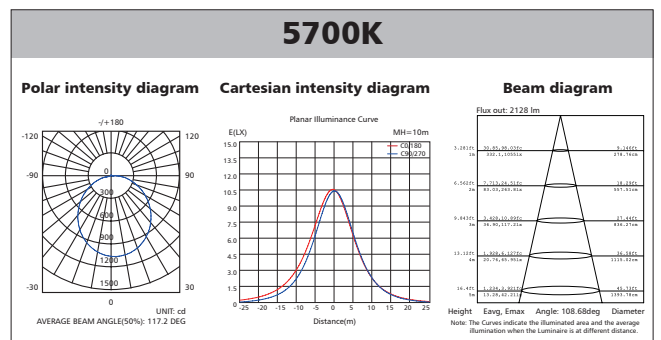
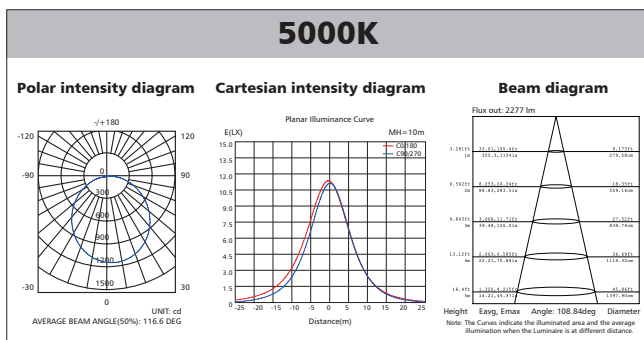
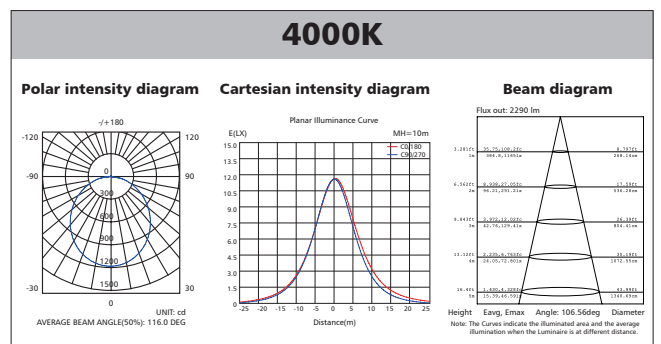
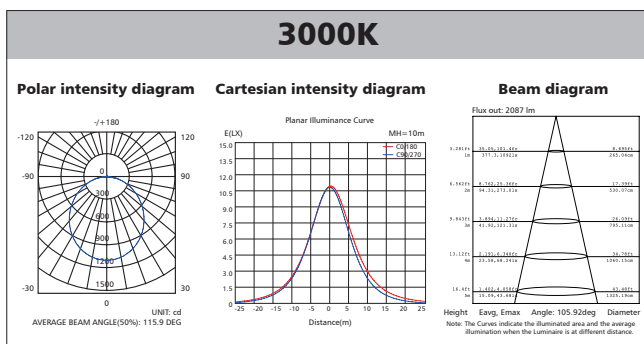

Polar Diagram Comparison

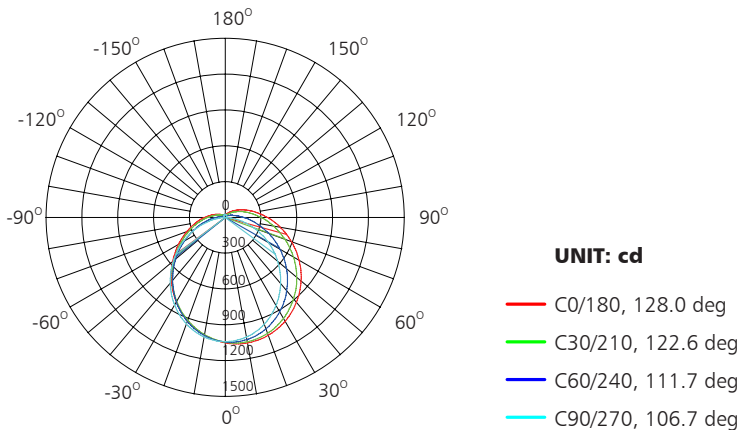

AVERAGE BEAM ANGLE (50%): 117.2DEG

Driver lifetime & LED light decay rate

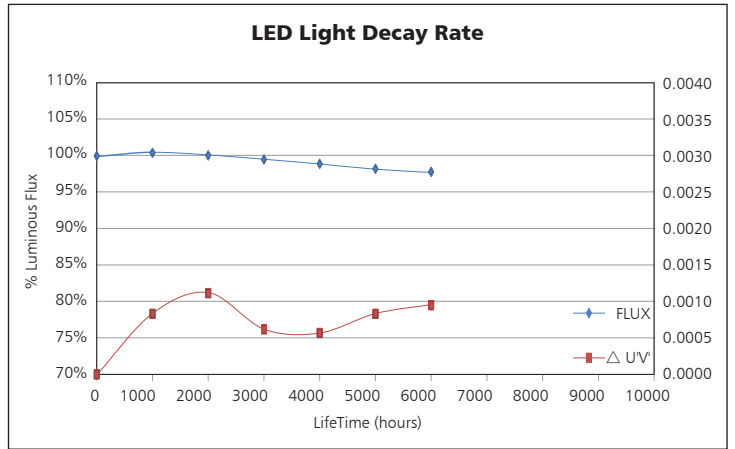
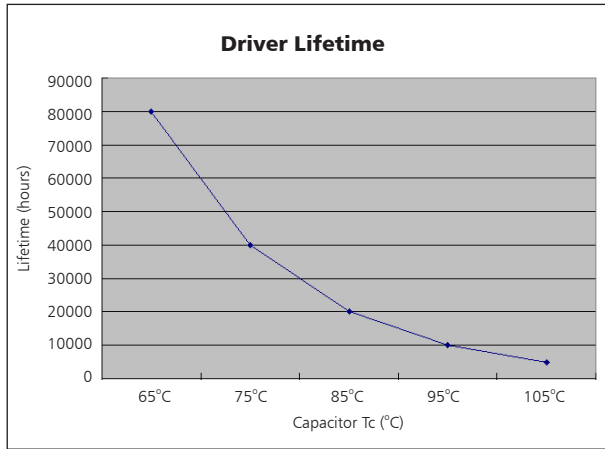

Temperature

- The testing is operated at 25°C
- The lifetime of capacitor, minimum of 5,000 hours if operated at 105°C, will be doubled whenever the temperature drops 10°C
- The highest withstand temperature of IC, MOS could be 120°C
- The highest withstand temperature of LED junction temperature is 150°C

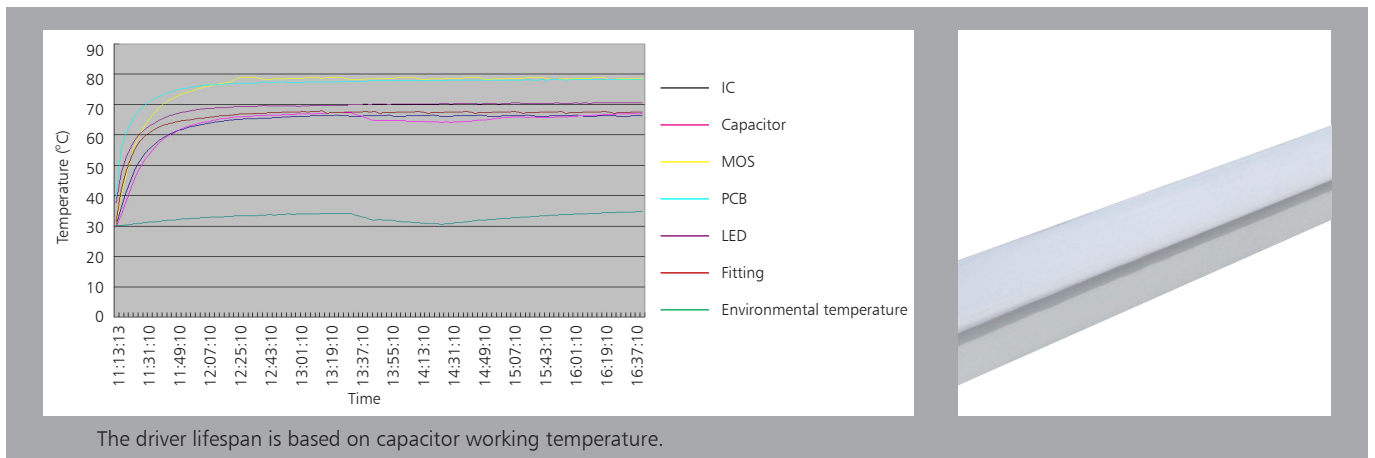

Installation 1

STEP 1

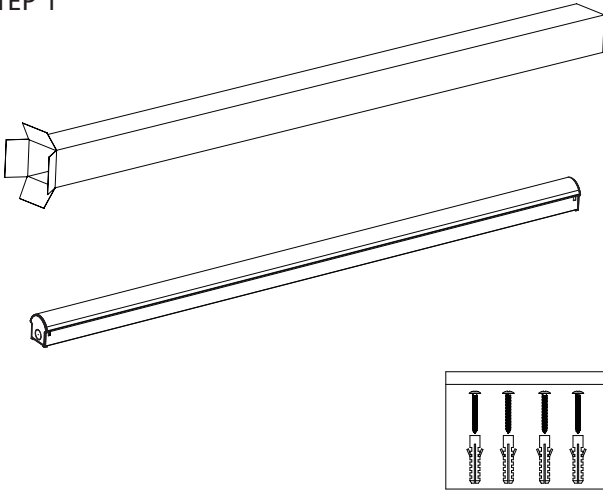

Open the packing and take out the lamp

STEP 2

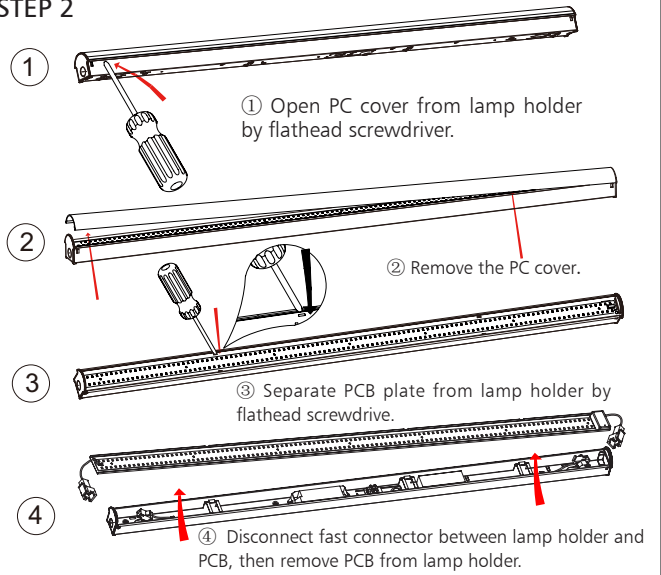

STEP 3

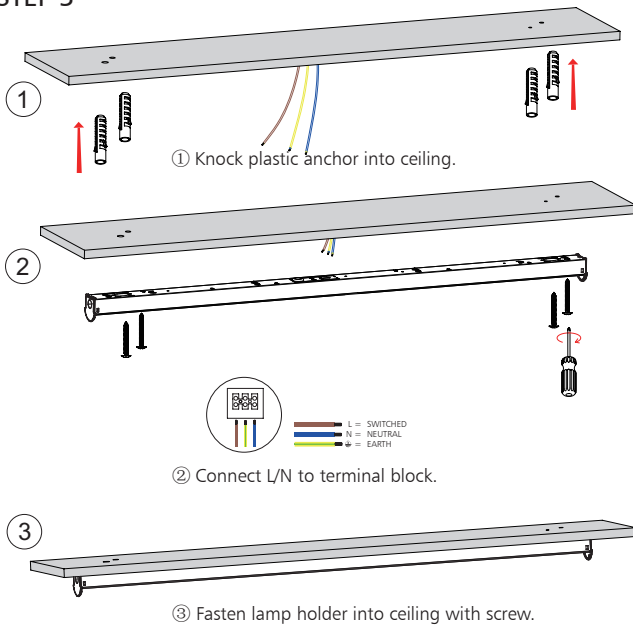

STEP 4

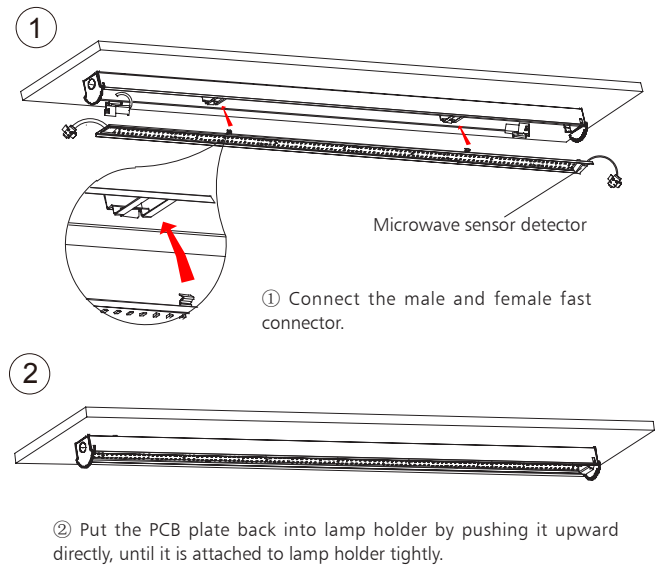

STEP 5

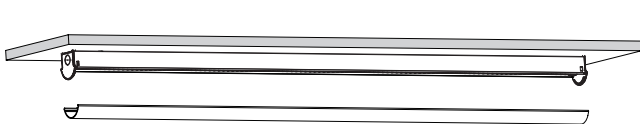

Pushing PC cover back to lamp holder by hands, until it is firmly fixed.

STEP 6

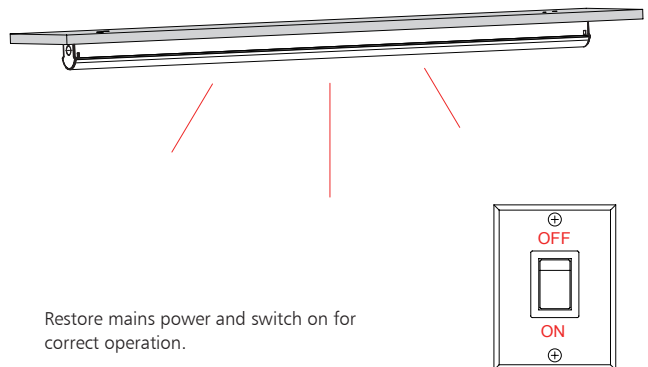

Restore mains power and switch on for correct operation.

Installation 2

STEP 1

Open box and take out lamp with accessories.

STEP 2

① Pried up the suspension hole by screwdriver.

② Pried up the terminal block on lamp holder.

Connect L/N to terminal block.

STEP 3

Hang fixture to ceiling with hanging wire.

Packaging Information

	SIZE(CM)	N.W/pc (KGS)	G.W.(KGS)	QTY(PCS)
Carton	129.5*34.5*15.5	1.65	19.5	10

	CTNS	QTY(PCS)	VOLUME(CBM)
20" standard container	398	3980	28
40" standard container	796	7960	56

