



UPSHINE[®]



Technical Application
Guide for UP-SHINE
LED Batten
UP-DB05C-30W

Introduction



Up-shine batten realizes elegant design, low cost, super slim construction and superior capability, aluminium profile body for good thermal dissipate, surface color treatment is customizable. Easy installation provided with surface mounted and suspended. It is a high efficient and low cost product with quite large potential market.

- Up to 70% energy saving compared to standard CFL
- Long lifetime of 40,000 hours
- 120° wide beam angle
- CCT: 3000K 4000K
5000K 5700K
- No UV/IR light
- Environment friendly, without Mercury or any other hazardous substances

Application notes

- IP20 for indoor use only
- The lamp must be installed by professional electrician
- Ensure the power supply is switched off before fitting this product
- Do not touch the lamp when in use
- Keep away from hot steam and corrosive gas

Application Areas

Widely used in office, meeting room, hotel, school etc.

Certificate

CE RoHS SAA



Product Information

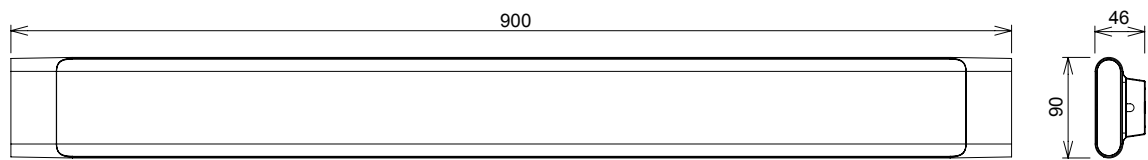

Technical Specifications

Model	Voltage	Power	Power Factor	Lumen (±5%)	Beam angle	CCT	Lifespan	CRI	Dimmable	Dimension
UP-DB05C-30W	AC100-240V	30W	≥0.9	2600	120°	3000K	40000h	≥80	No	L900*W90*H46mm
UP-DB05C-30W	AC100-240V	30W	≥0.9	2630	120°	4000K	40000h	≥80	No	L900*W90*H46mm
UP-DB05C-30W	AC100-240V	30W	≥0.9	2610	120°	5000K	40000h	≥80	No	L900*W90*H46mm
UP-DB05C-30W	AC100-240V	30W	≥0.9	2560	120°	5700K	40000h	≥80	No	L900*W90*H46mm
UP-DB05C-30W-D	AC230V	30W	≥0.9	2450	120°	3000K	40000h	≥80	Yes	L900*W90*H46mm
UP-DB05C-30W-D	AC230V	30W	≥0.9	2490	120°	4000K	40000h	≥80	Yes	L900*W90*H46mm
UP-DB05C-30W-D	AC230V	30W	≥0.9	2480	120°	5000K	40000h	≥80	Yes	L900*W90*H46mm
UP-DB05C-30W-D	AC230V	30W	≥0.9	2430	120°	5700K	40000h	≥80	Yes	L900*W90*H46mm

Driver data Sheet

Driver data	DIM	Non dim
Input rated Voltage	AC230V	AC100-240V
Frequency	50Hz	50/60Hz
Input Voltage	AC200-240V	AC85-265V
Efficiency	≥85%	≥90%
Total load Wattage	30W±5%	30W±5%
Power Factor	≥0.9	≥0.9
Rated input current	≤0.17A	≤0.34A
Full load output Voltage	DC65-78V	DC65-78V
Rated output current	180mA*2	200mA*2
Output current range	180mA*2±5%	200mA*2±5%
Power tolerance	±5%	±5%
Current output tolerance	±5%	±5%
Dimming range	8%-100%	—
Dimmer	Triac dimmers	—
Short circuit protection	PASS	PASS
Over voltage protection	PASS	PASS
Over temperature protection	PASS	PASS
THD	≤30%	≤20%
Withstand voltage	AC1500V	AC1500V

Fixture Compatibility

Rated Wattage	Electrical Classification	Ingress Protection	Operating Temp	Operating Humidity	Storage Temp
30W	I	IP20	-20°C~45°C	0~90%	-20°C~65°C

Spectral Distribution

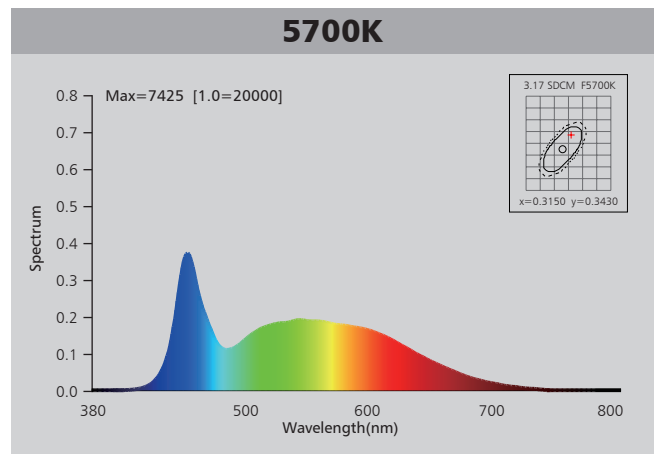
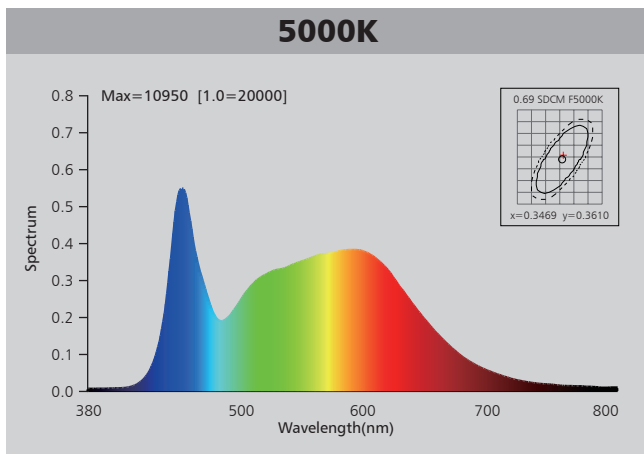
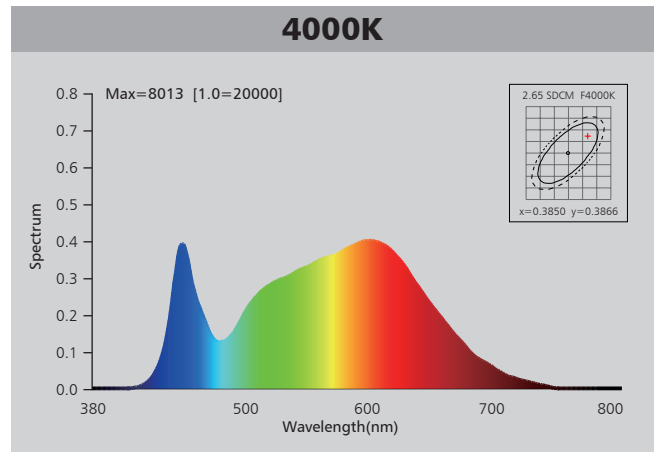
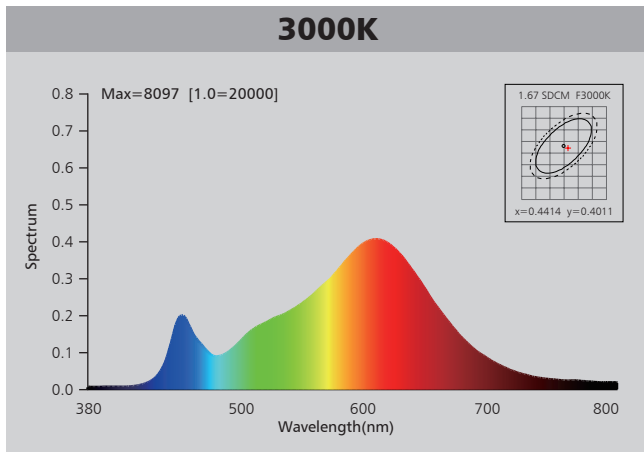

Photometric Diagram

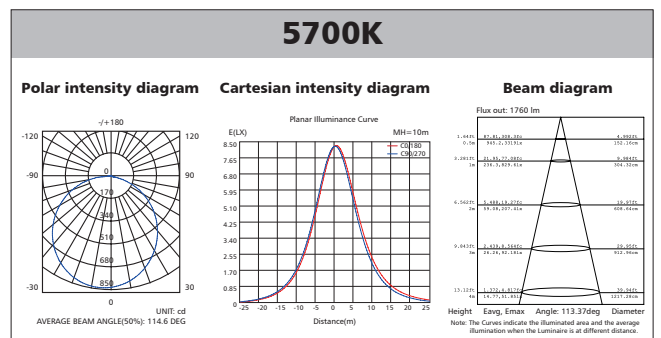
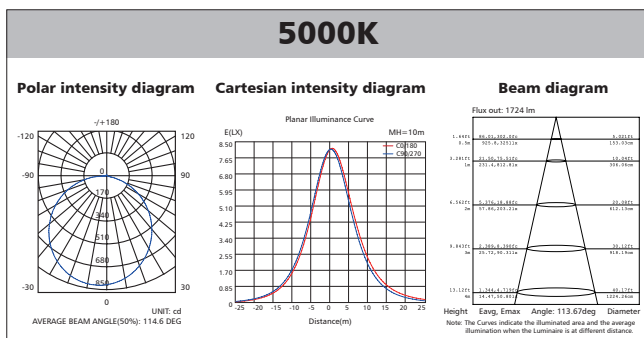
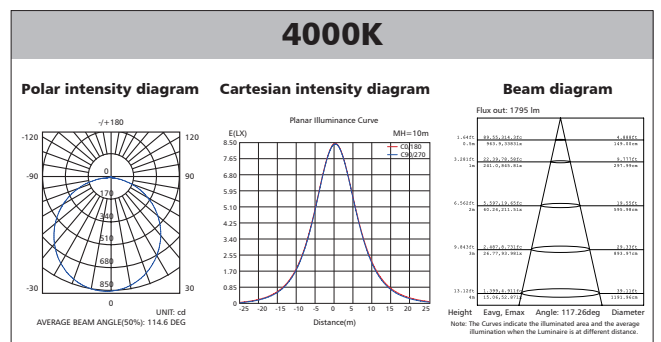
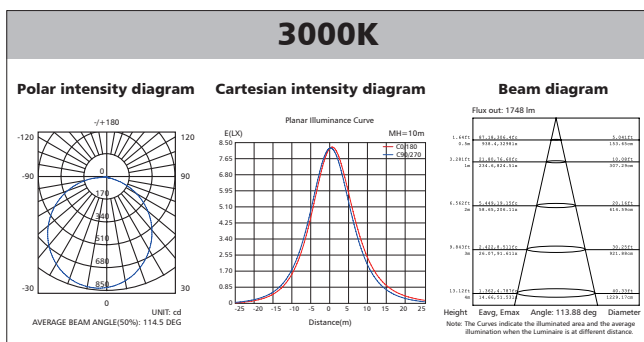

Polar Diagram Comparison

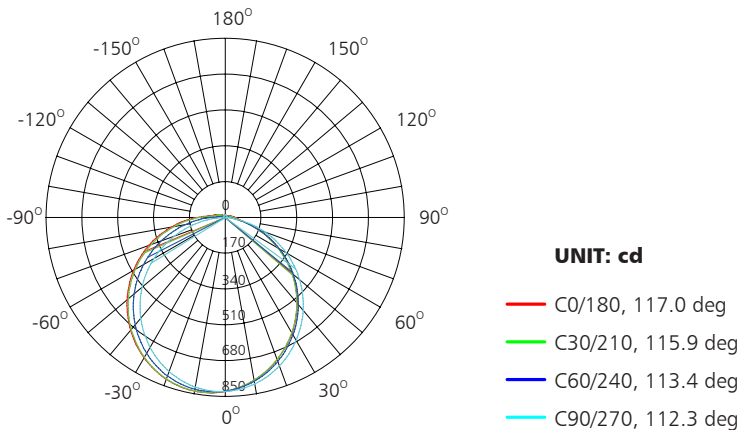

AVERAGE BEAM ANGLE (50%): 114.6DEG

Driver lifetime & LED light decay rate

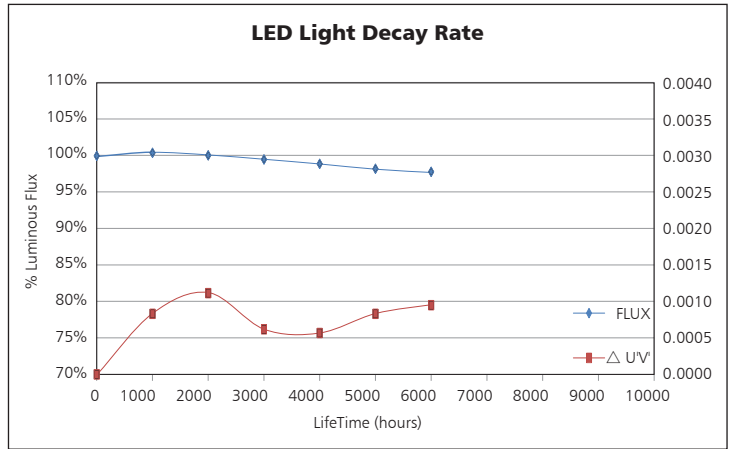
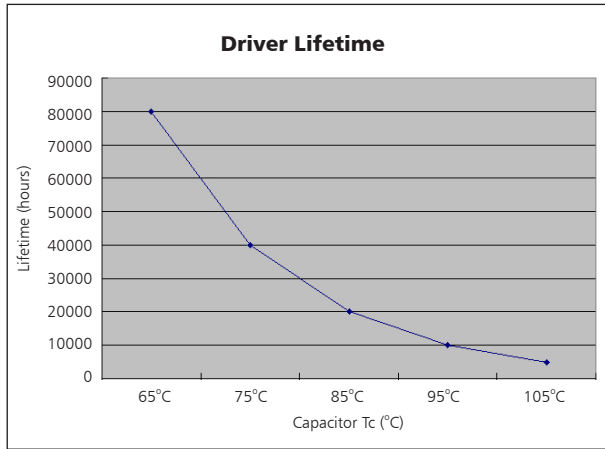

Temperature

- The testing is operated at 25°C
- The lifetime of capacitor, minimum of 5,000 hours if operated at 105°C, will be doubled whenever the temperature drops 10°C
- The highest withstand temperature of IC, MOS could be 120°C
- The highest withstand temperature of LED junction temperature is 150°C

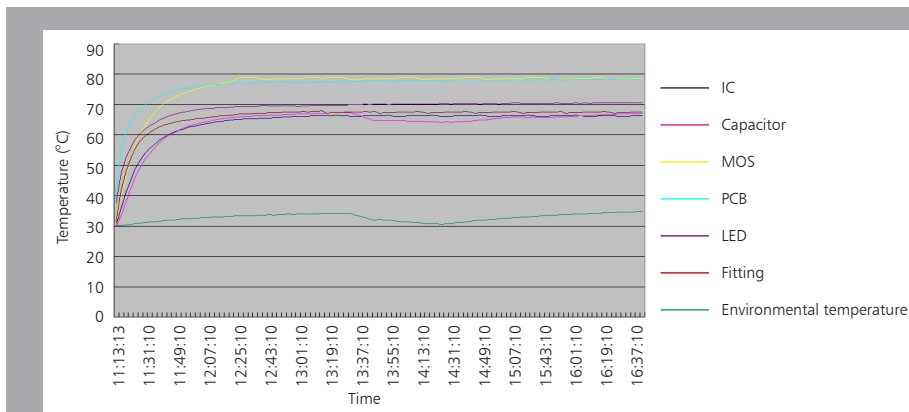

The driver lifespan is based on capacitor working temperature.

Surface mount

1. Fix the mounting bracket on ceiling or wall, input conduction wires from the middle.

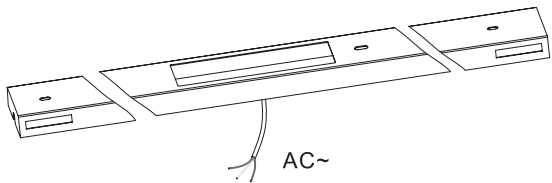

AC~

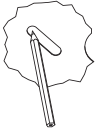

Mark hole fixing centres

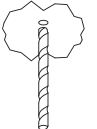

Drill holes



Insert rawl plug into hole

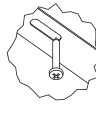

Fix in position

2. Fix the spring clips on the back of lamp by screws.

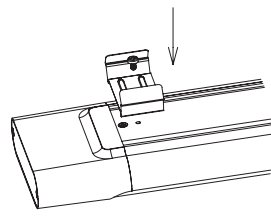

3. Connect the AC wire to lamp by wiring terminal on the back.

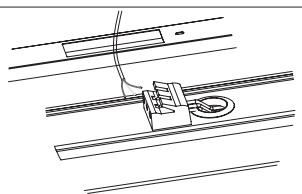

— L= Brown

— N= Blue

— ⊕= Yellow-Green

4. Attach the lamp to mounting bracket: Push lamp into mounting bracket, make the spring clips stuck in bracket.

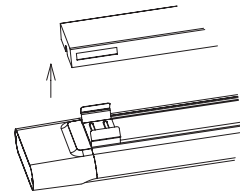

5. Connect to the power supply, installation complete.

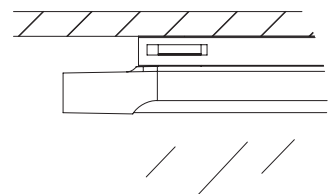

Packaging Information

	SIZE(CM)	N.W/pc (KGS)	G.W.(KGS)	Q'TY(PCs)
Carton	93.5*30.5*24	1.3	16	12

	CTNS	Q'TY(PCs)	VOLUME(CBM)
20" standard container	403	4836	28
40" standard container	806	9672	56

