



UPSHINE[®]



Technical Application
Guide for UP-SHINE
LED Batten
UP-DB05B-40W

Introduction

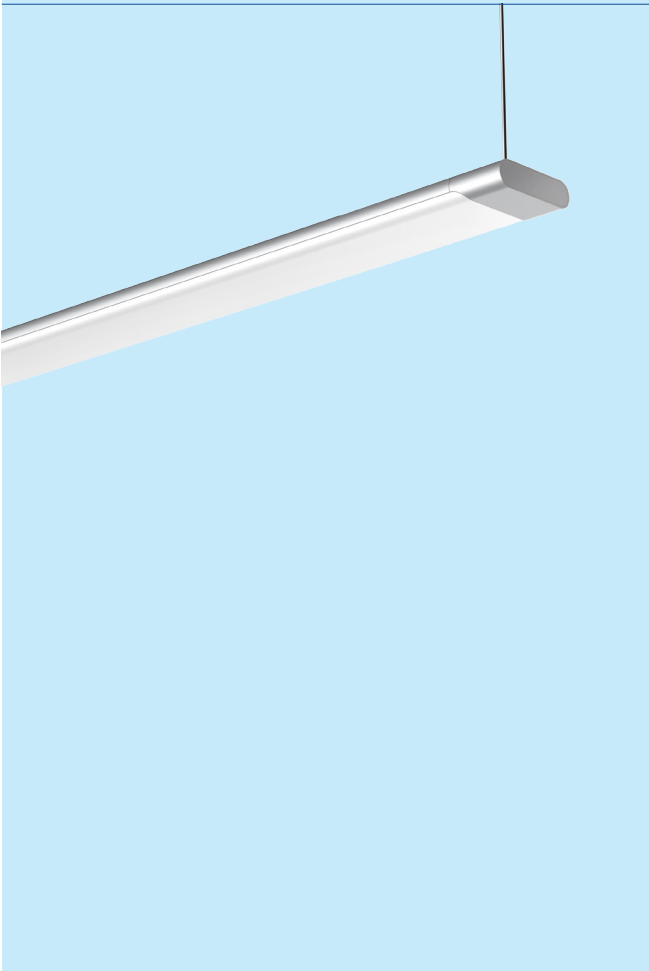

Up-shine batten realizes elegant design, low cost, super slim construction and superior capability, aluminium profile body for good thermal dissipate, surface color treatment is customizable. Easy installation provided with surface mounted and suspended. It is a high efficient and low cost product with quite large potential market.

- Up to 70% energy saving compared to standard CFL
- Long lifetime of 40,000 hours
- 120° wide beam angle
- CCT: 3000K 4000K
5000K 5700K
- No UV/IR light
- Environment friendly, without Mercury or any other hazardous substances

Application notes

- IP20 for indoor use only
- The lamp must be installed by professional electrician
- Ensure the power supply is switched off before fitting this product
- Do not touch the lamp when in use
- Keep away from hot steam and corrosive gas

Application Areas

Widely used in office, meeting room, hotel, school etc.

Certificate

CE **RoHS** **SAA**



Product Information

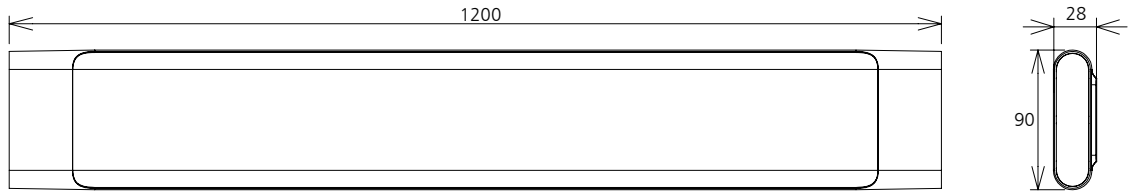

Technical Specifications

Model	Voltage	Power	Power Factor	Lumen (±5%)	Beam angle	CCT	Lifespan	CRI	Dimmable	Dimension
UP-DB05B-40W	AC100-240V	40W	≥0.9	3450	120°	3000K	40000h	≥80	No	L1200*W90*H28mm
UP-DB05B-40W	AC100-240V	40W	≥0.9	3540	120°	4000K	40000h	≥80	No	L1200*W90*H28mm
UP-DB05B-40W	AC100-240V	40W	≥0.9	3420	120°	5000K	40000h	≥80	No	L1200*W90*H28mm
UP-DB05B-40W	AC100-240V	40W	≥0.9	3500	120°	5700K	40000h	≥80	No	L1200*W90*H28mm
UP-DB05B-40W-D	AC230V	40W	≥0.9	3240	120°	3000K	40000h	≥80	Yes	L1200*W90*H28mm
UP-DB05B-40W-D	AC230V	40W	≥0.9	3360	120°	4000K	40000h	≥80	Yes	L1200*W90*H28mm
UP-DB05B-40W-D	AC230V	40W	≥0.9	3250	120°	5000K	40000h	≥80	Yes	L1200*W90*H28mm
UP-DB05B-40W-D	AC230V	40W	≥0.9	3330	120°	5700K	40000h	≥80	Yes	L1200*W90*H28mm

Driver data Sheet

Driver data	DIM	Non dim
Input rated Voltage	AC230V	AC100-240V
Frequency	50Hz	50/60Hz
Input Voltage	AC200-240V	AC85-265V
Efficiency	≥85%	≥90%
Total load Wattage	40W±5%	40W±5%
Power Factor	≥0.9	≥0.9
Rated input current	≤0.23A	≤0.46A
Full load output Voltage	DC65-78V	DC65-78V
Rated output current	240mA*2	260mA*2
Output current range	240mA*2±5%	260mA*2±5%
Power tolerance	±5%	±5%
Current output tolerance	±5%	±5%
Dimming range	8%-100%	—
Dimmer	Triac dimmers	—
Short circuit protection	PASS	PASS
Over voltage protection	PASS	PASS
Over temperature protection	PASS	PASS
THD	≤30%	≤20%
Withstand voltage	AC1500V	AC1500V

Fixture Compatibility

Rated Wattage	Electrical Classification	Ingress Protection	Operating Temp	Operating Humidity	Storage Temp
40W	I	IP20	-20°C~45°C	0~90%	-20°C~65°C

Spectral Distribution

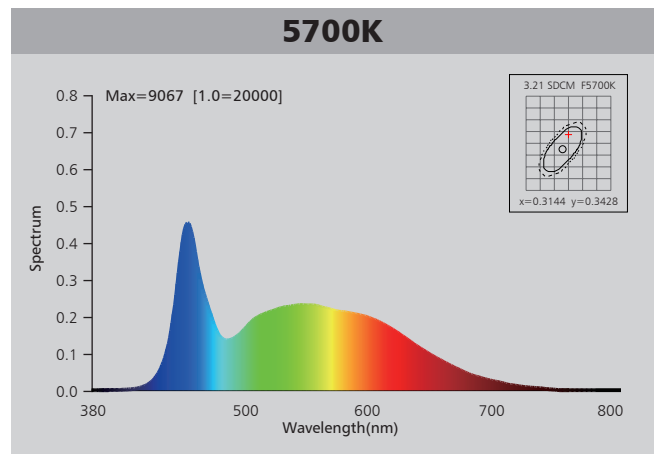
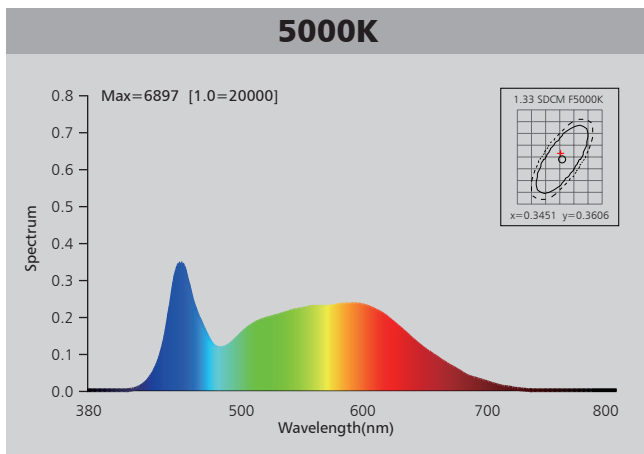
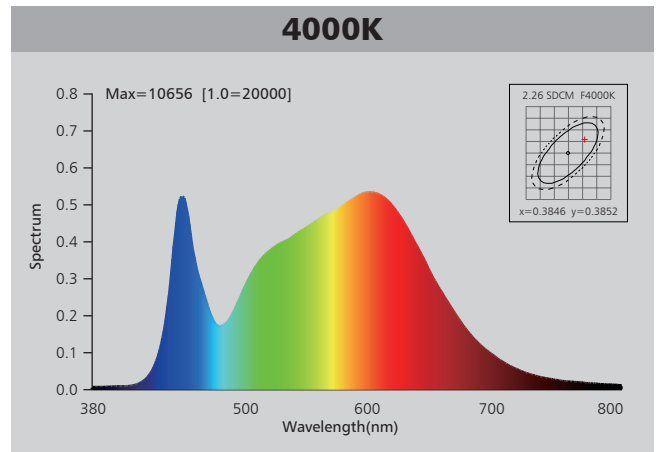
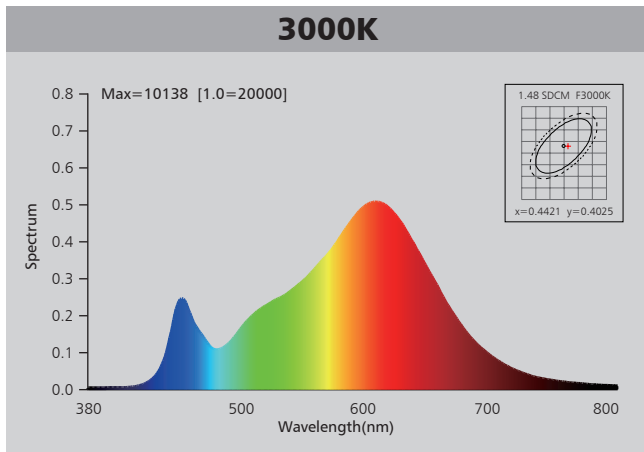

Photometric Diagram

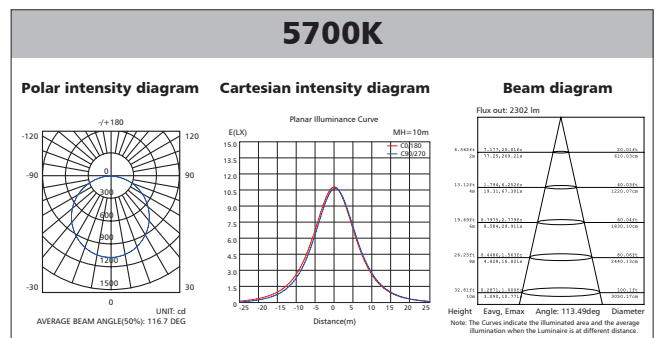
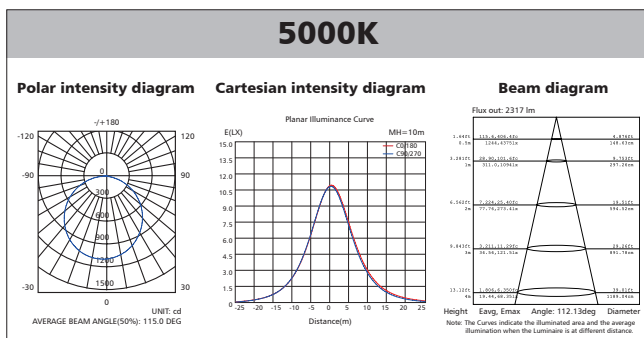
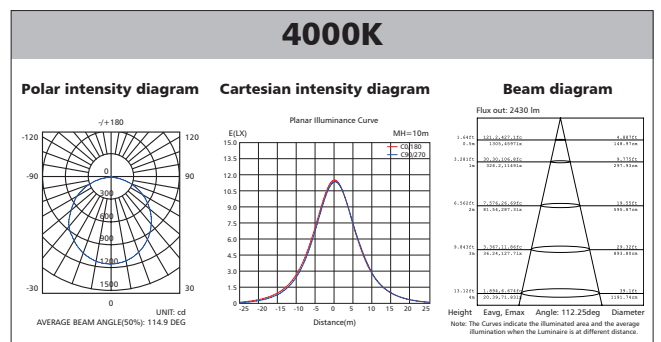
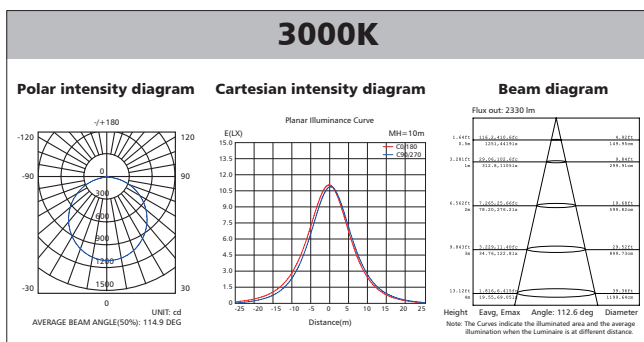

Polar Diagram Comparison

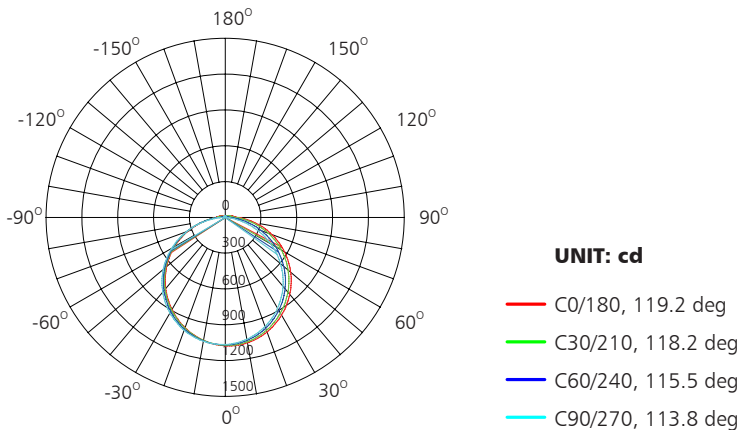

AVERAGE BEAM ANGLE (50%): 116.7DEG

Driver lifetime & LED light decay rate

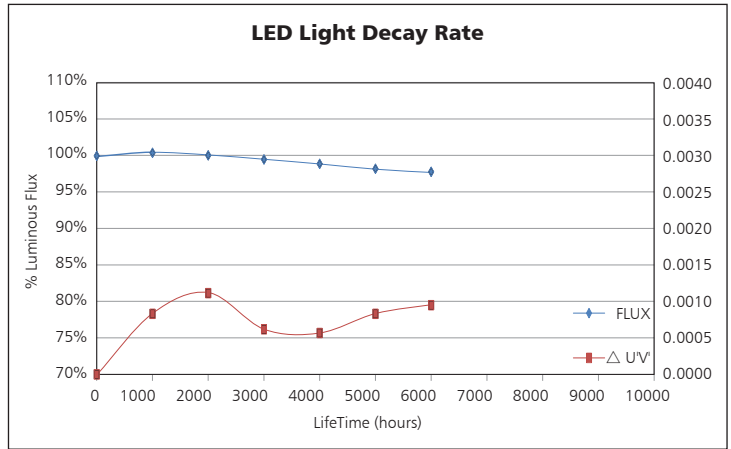
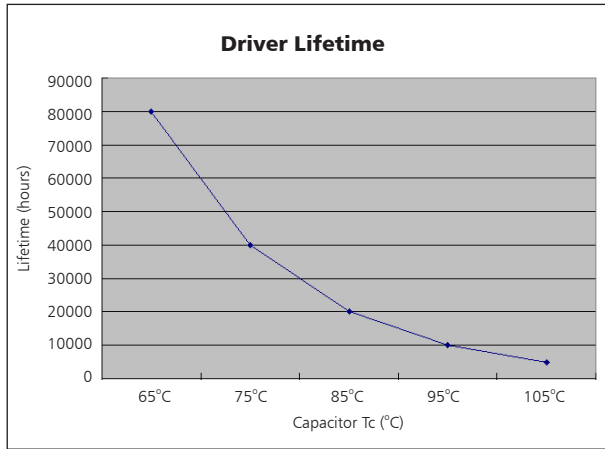

Temperature

- The testing is operated at 25°C
- The lifetime of capacitor, minimum of 5,000 hours if operated at 105°C, will be doubled whenever the temperature drops 10°C
- The highest withstand temperature of IC, MOS could be 120°C
- The highest withstand temperature of LED junction temperature is 150°C

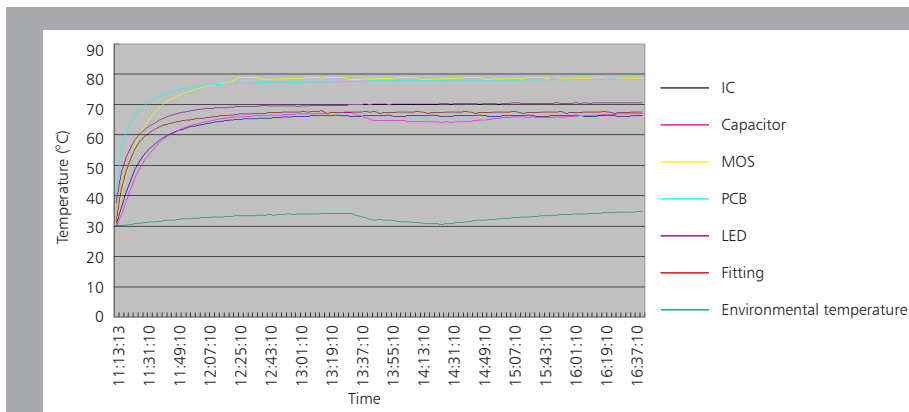

The driver lifespan is based on capacitor working temperature.

Suspend install

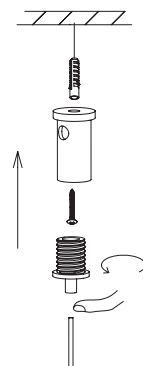

1. Fix the holders of suspending ropes on the ceiling.

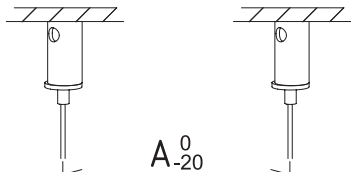

2. Keep the proper distance of the 2 pcs suspending ropes as below table.

SPEC.	A ₋₂₀ ⁰
600mm	464mm
900mm	764mm
1200mm	1064mm

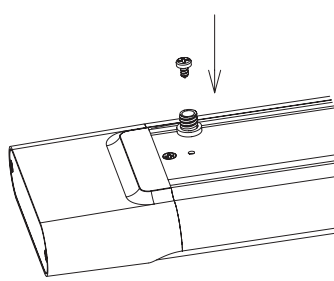

3. Fix the pedestal of installation ropes on the lamp by screws.

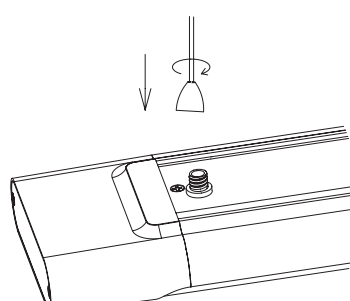

4. Screw the ropes into the pedestals.

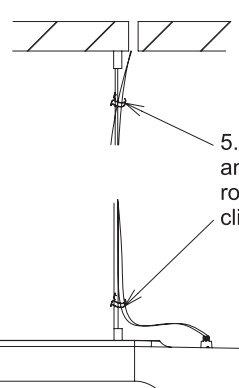

5. Bind the AC wires and suspending ropes together by clips.

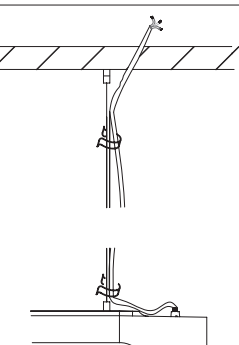

6. Connect to the power supply, installation complete.

- L= Brown
- N= Blue
- ⊕= Yellow-Green

Surface mount

1. Fix the mounting bracket on ceiling or wall, input conduction wires from the middle.

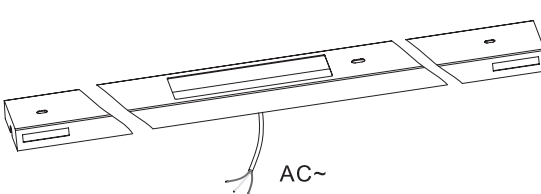

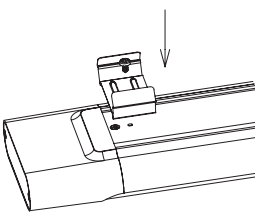

2. Fix the spring clips on the back of lamp by screws.

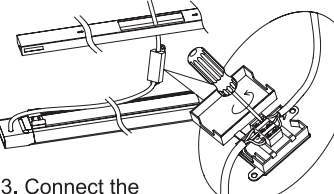

3. Connect the fixture lead with AC supplier wires by junction box.

- L= Brown
- N= Blue
- ⊕= Yellow-Green

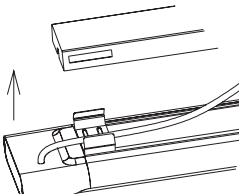

4. Attach the lamp to mounting bracket: Push lamp into mounting bracket, make the spring clips stuck in bracket.

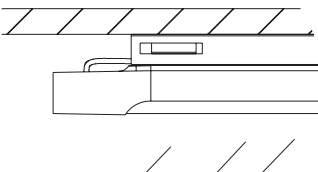

5. Connect to the power supply, installation complete.

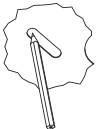

Mark hole fixing centres



Drill holes



Insert rawl plug into hole



Fix in position

Packaging Information

	SIZE(CM)	N.W/pc (KGS)	G.W.(KGS)	Q'TY(PCS)
Carton	126.5*21*26	1.4	21.2	12

	CTNS	Q'TY(PCS)	VOLUME(CBM)
20" standard container	400	4800	28
40" standard container	800	9600	56

