



Supermarket Lighting Case

www.upshine.com

CONTENTS

- Case Show
- Product Introduced
- Installation Notes

PART ONE

Case Show



In the hypermarket & supermarket places where correct lighting can enhance your customer's buying experience and come back next time

Supermarket Lighting in Germany





Supermarket LED Track Lighting in France





ROTISSERIE
de la Coop
16.95

PART TWO

Product Introduced



LED Track Light TL02

- Up to 70% energy saving compared to standard CFL
- Long lifetime of 40,000 hours
- 15° 30° 45° beam angle
- CCT: 2700K 3000K
- 4000K 5000K
- No UV/IR light
- Environment friendly, without Mercury or any other hazardous substances



PART TWO

Product Introduced



LED Track Light TL09

Up-shine track light adopts COB LEDs with excellent color rendering index to increase the color fidelity of the target illuminated object. Providing excellent heat dissipation, even light output without glare & dark spot.



PART Three

Installation Notes

TL02 LED Track Light with Easy Install

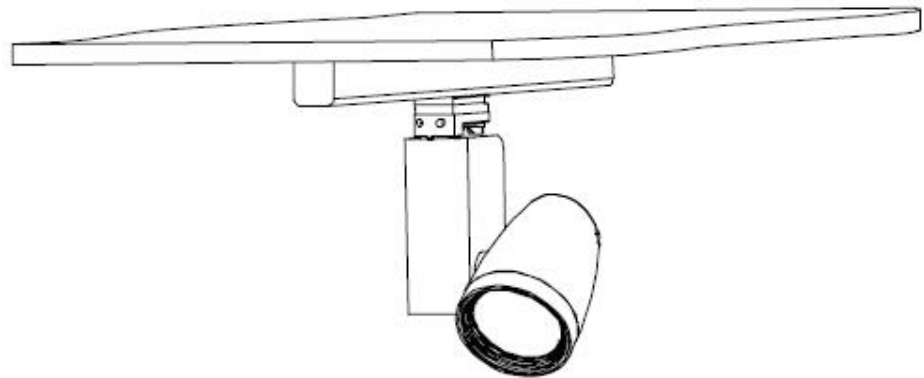
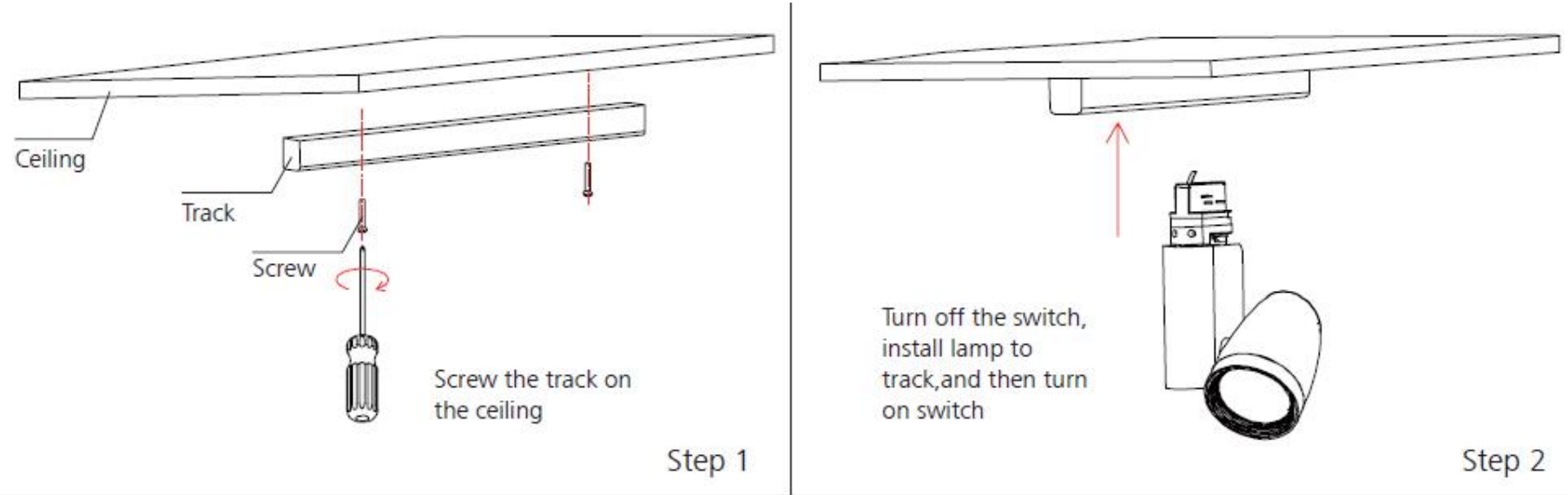

Finished

Step 3

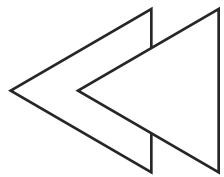

PART Three

Installation Notes

TL09 LED Track Light with Easy Intsall

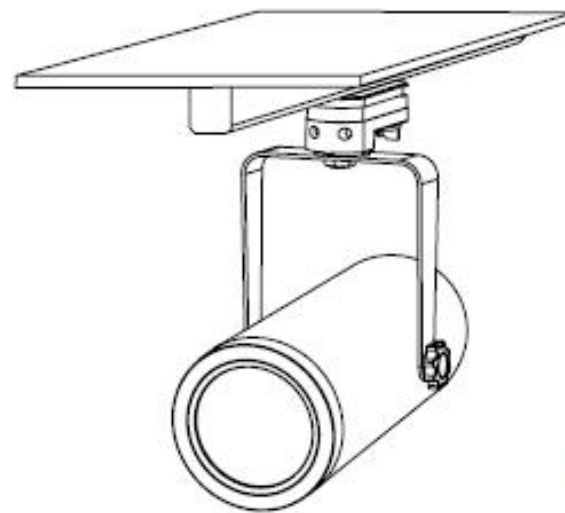
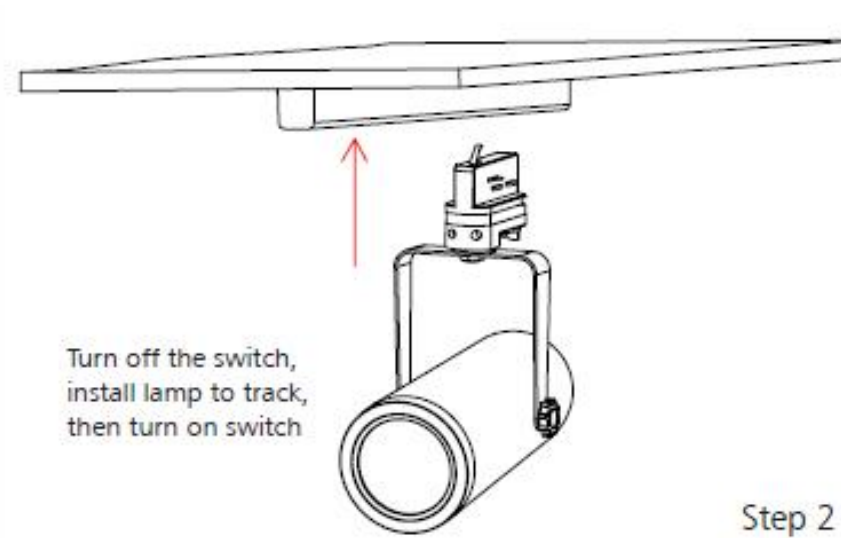
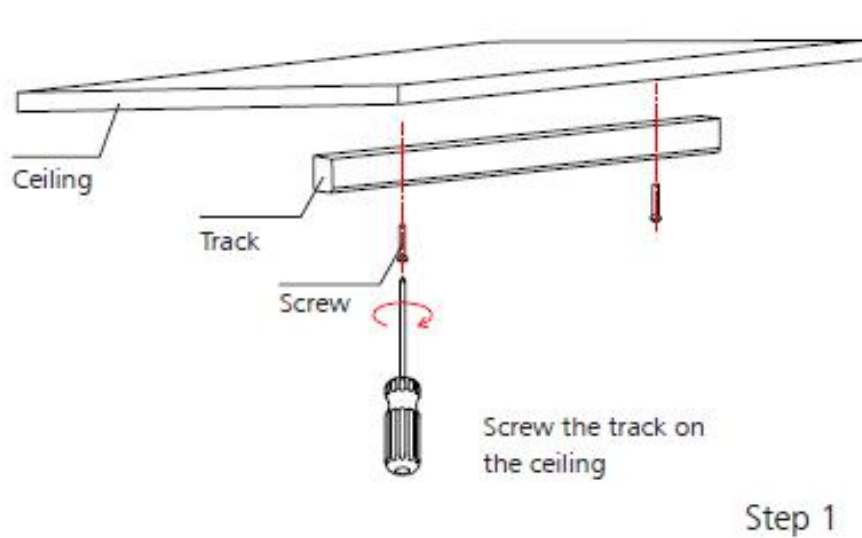

Finished

Step 3



THANK!

WWW.UPSHINE.COM