

# Vero Moda Retail Shop Lighting Case



# CONTENTS

- Case Show
- Product Introduced
- Installation Notes

# PART ONE

## Case Show

### Vero Moda Retail Shop Lighting in Spain





# PART TWO

## Product Introduced



### UPSHINE TL02 LED Track Light

- Up to 70% energy saving compared to standard CFL
- Long lifetime of 40,000 hours
- 15° 30° 45° beam angle
- CCT: 2700K 3000K
- 4000K 5000K
- No UV/IR light
- Environment friendly, without Mercury or any other hazardous substances



# PART Three

## Installation Notes

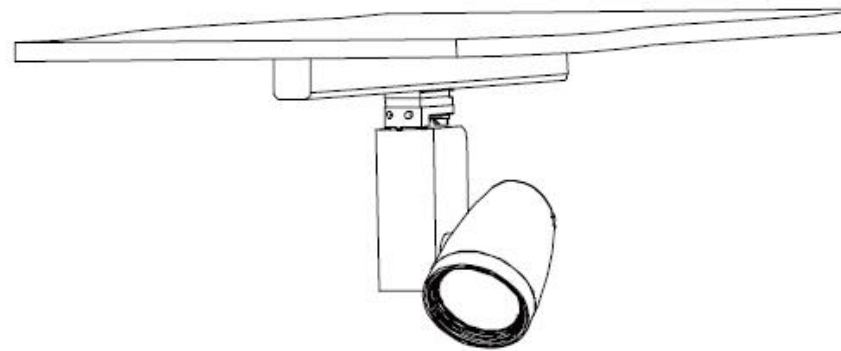
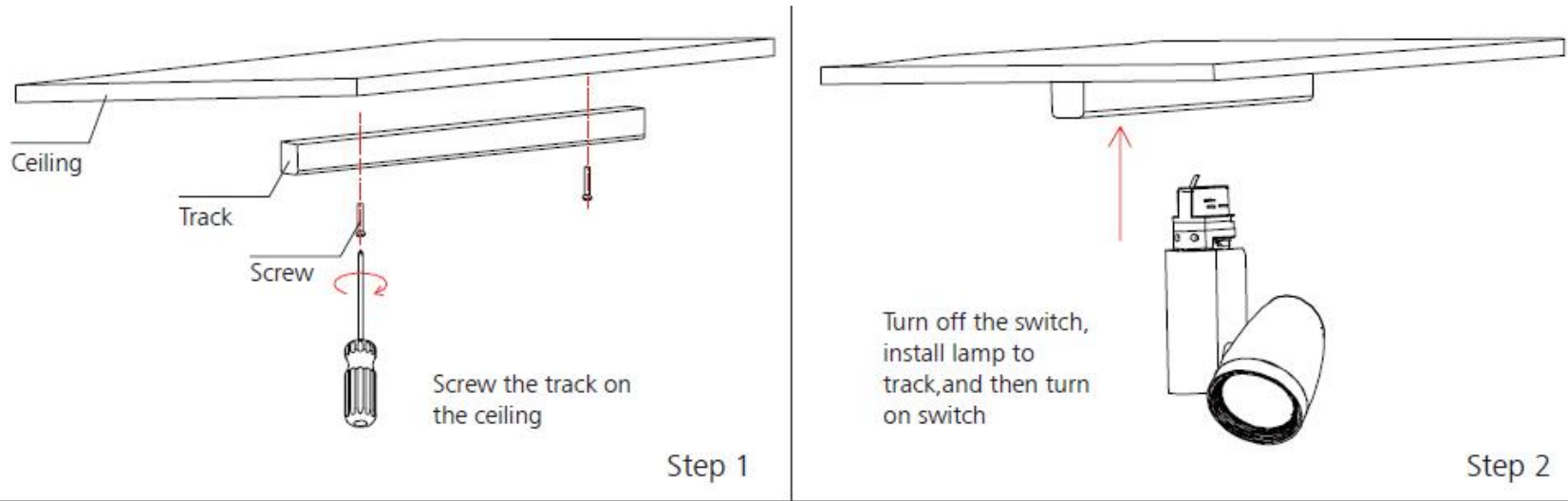

Finished

Step 3



# THANK!

---

[WWW.UPSHINE.COM](http://WWW.UPSHINE.COM)