



Up-shine<sup>®</sup> Lighting



Technical Application  
Guide for UP-SHINE  
LED Track Light

UP-TL14-10W

# Introduction



Up-shine ceiling spotlight adopts die-casting ADC12 with excellent heat dissipation. CRI80 and high efficient COB led chip to assure that high center luminous intensity. It is designed with high transmittance glass, maximum utilization of light output. Adjustable lighting orientation with 350 degree in horizontal direction and 35 in vertical direction provided.

- Up to 70% energy saving compared to standard CFL
- Long lifetime of 40,000 hours
- 24°/36°/45°/60° beam angle
- CCT: 2700K 3000K  
4000K 5000K
- No UV/IR light
- Environment friendly, without Mercury or any other hazardous substances

## Application notes

- IP20 for indoor use only
- Professional electrician for installation only
- Switch off before installation
- Do not touch when in use
- Keep away from hot steam and corrosive gas

## Application Areas

It is suitable for supermarket, specialty store, show window, exhibition hall; focus lighting, decorative and background lighting, where attention is focused on subjects to emphasize special visual points.

## Certificate



# Product Information

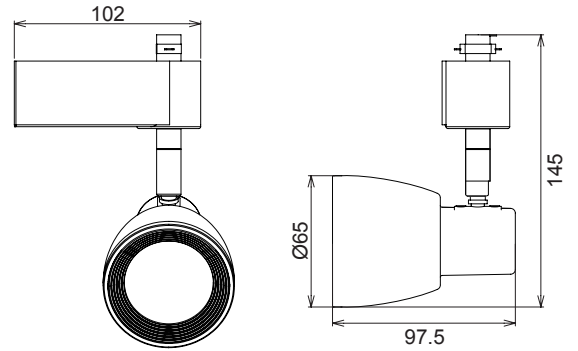

## Technical Specifications

Model	Voltage	Power	Power Factor	Lumen (±5%)	Beam angle	CCT	Lifespan	CRI	Dimmable	Dimension
UP-TL14-10W	AC100-240V	10W	≥0.9	750	24°/36°/45°/60°	2700K	40000h	≥80	No	102*97.5*145mm
UP-TL14-10W	AC100-240V	10W	≥0.9	760	24°/36°/45°/60°	3000K	40000h	≥80	No	102*97.5*145mm
UP-TL14-10W	AC100-240V	10W	≥0.9	800	24°/36°/45°/60°	4000K	40000h	≥80	No	102*97.5*145mm
UP-TL14-10W	AC100-240V	10W	≥0.9	780	24°/36°/45°/60°	5000K	40000h	≥80	No	102*97.5*145mm

## Driver data Sheet

Driver data	Non-dim
Input rated Voltage	AC100-240V
Frequency	50/60Hz
Input Voltage	AC85-265V
Efficiency	≥85%
Total load Wattage	10±0.5W
Power Factor	≥0.9
Rated input current	≤0.12A
Full load output Voltage	DC24-38V
Rated output current	230mA
Output current range	230mA±5%
Power tolerance	±5%
Current output tolerance	±5%
Short circuit protection	PASS
Over voltage protection	PASS
Over temperature protection	PASS
Withstand voltage	AC1500V

## Fixture Compatibility

Rated Wattage	Electrical Classification	Ingress Protection	Operating Temp	Operating Humidity	Storage Temp
10W	I	IP20	-20°C~45°C	0~90%	-20°C~65°C

# Spectral Distribution

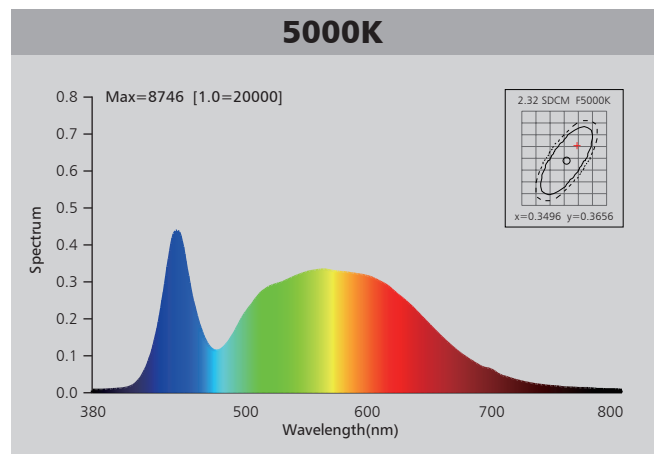
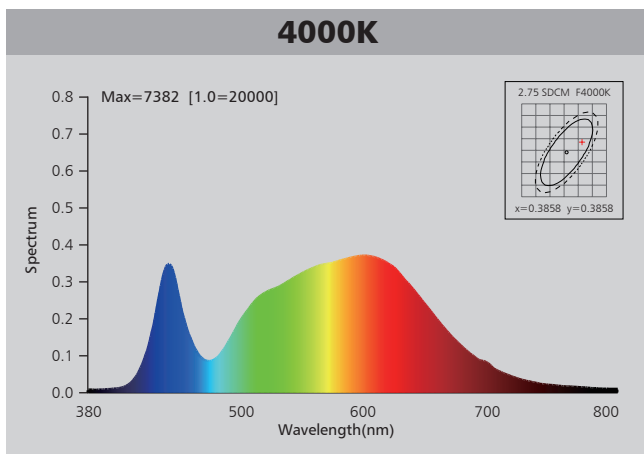
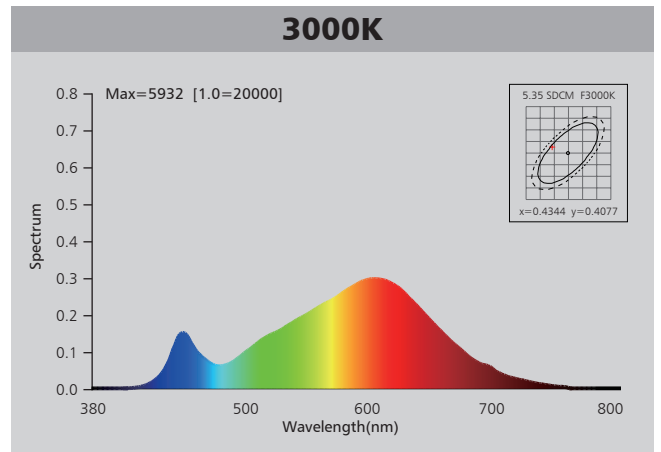
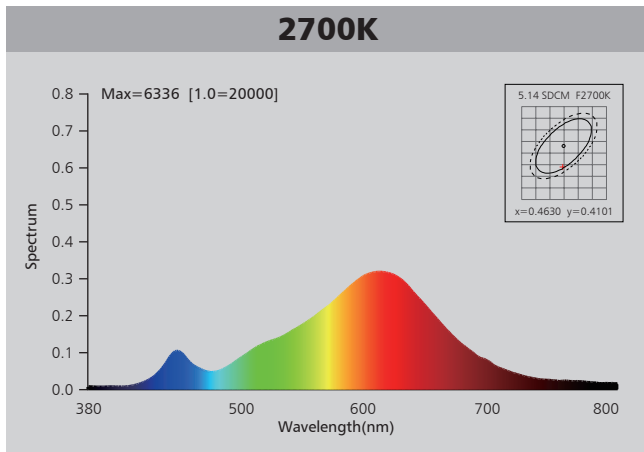

# Photometric Diagram

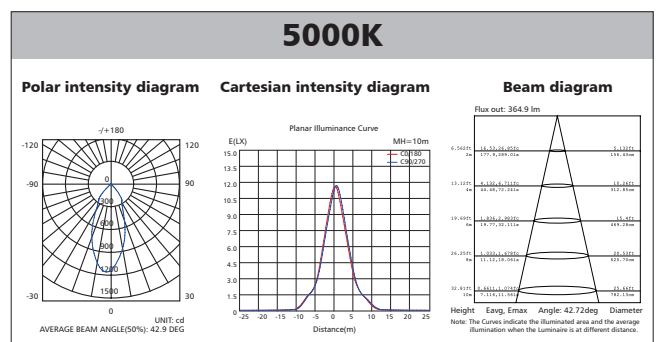
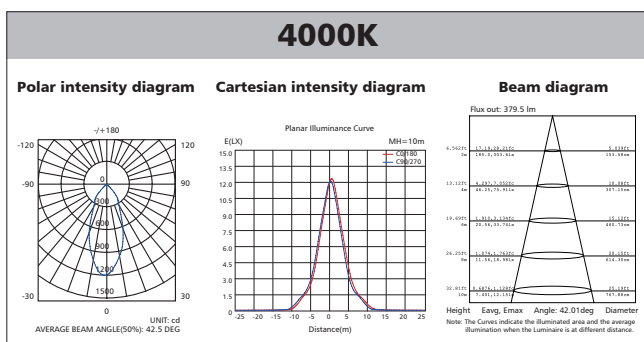
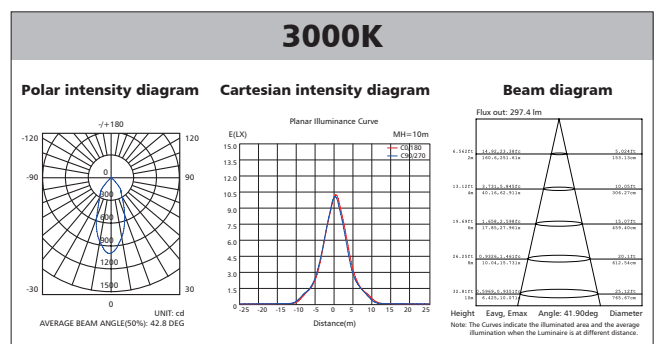
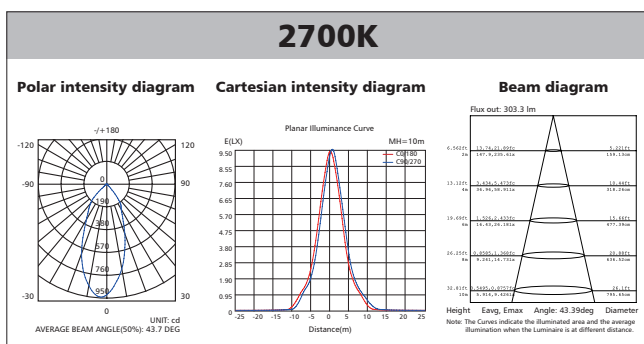

# Polar Diagram Comparison

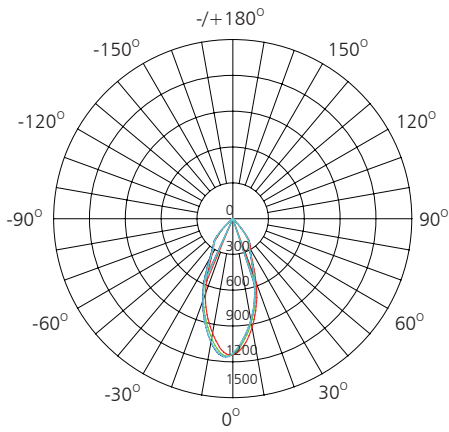

UNIT: cd

- C0/180, 42.8 deg
- C30/210, 43.1 deg
- C60/240, 43.0 deg
- C90/270, 42.8 deg

AVERAGE BEAM ANGLE (50%): 42.9DEG



# Driver lifetime & LED light decay rate

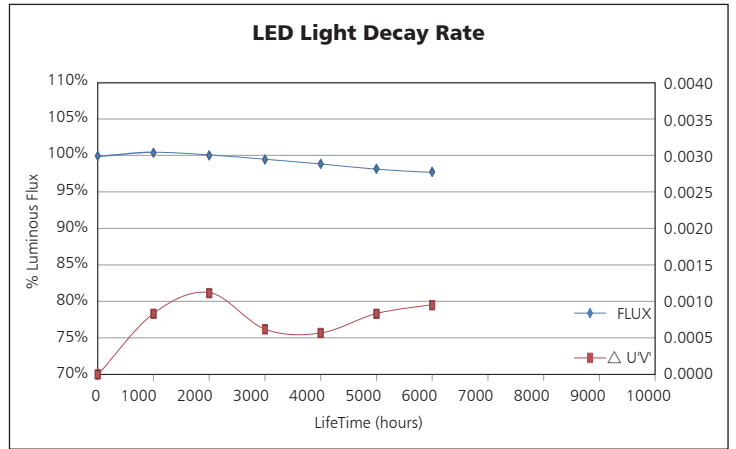
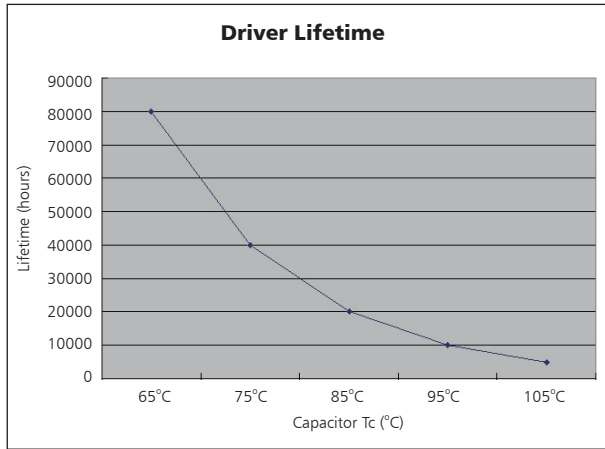

# Temperature

- The testing is operated at 25°C
- The lifetime of capacitor, minimum of 5,000 hours if operated at 105°C, will be doubled whenever the temperature drops 10°C
- The highest withstand temperature of IC, MOS could be 120°C
- The highest withstand temperature of LED junction temperature is 150°C

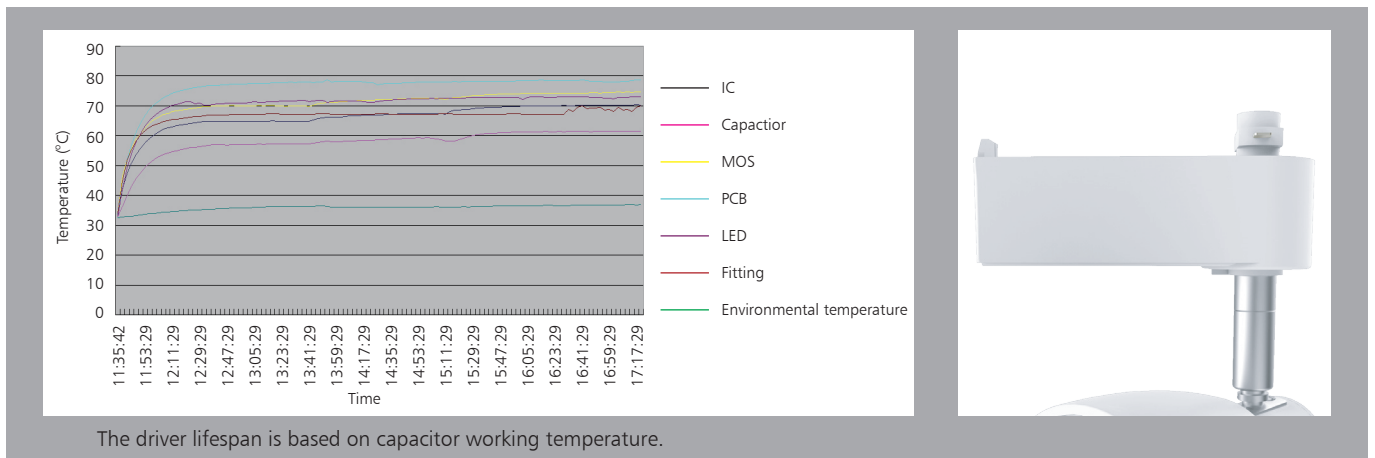

The driver lifespan is based on capacitor working temperature.

## Installation

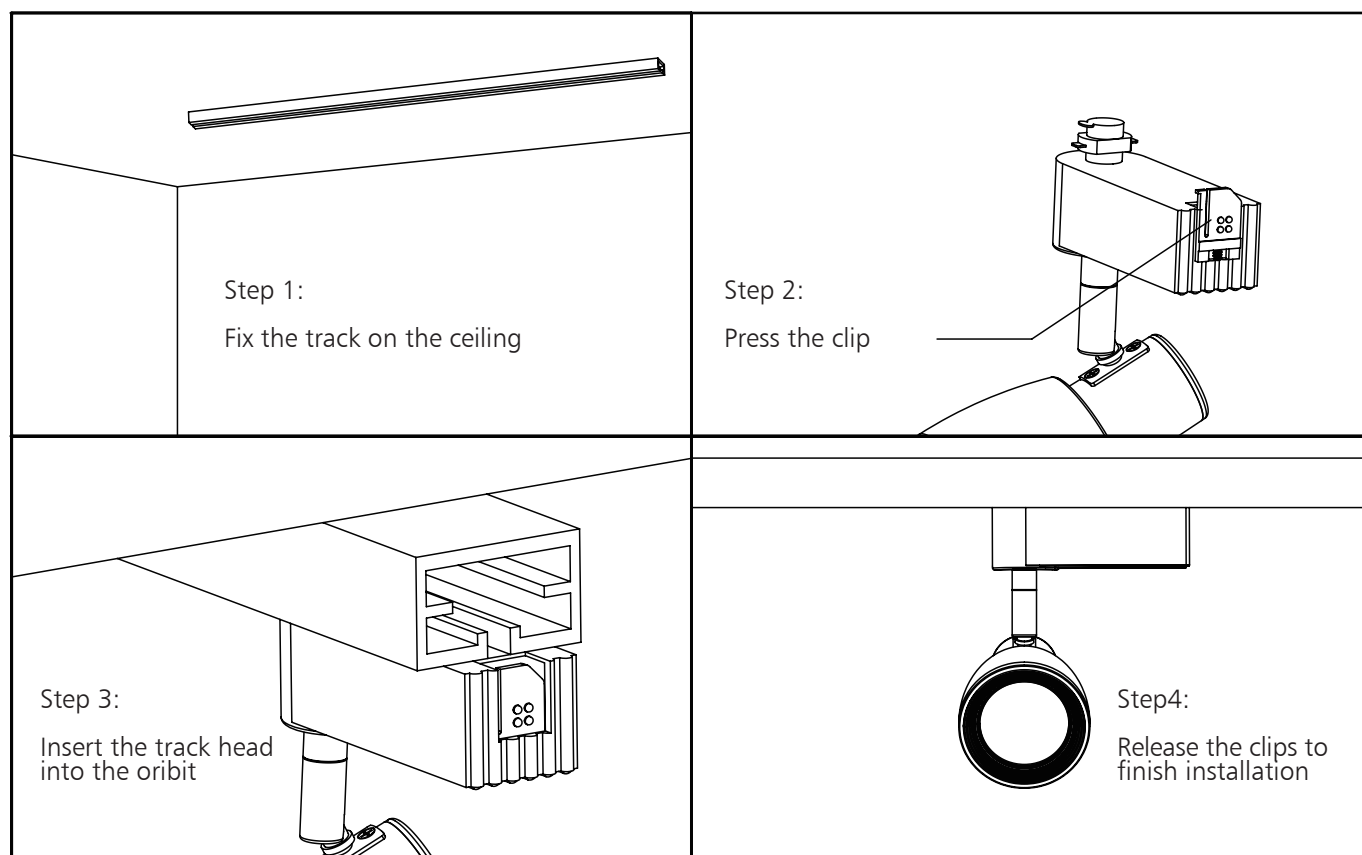

## Packaging Information

	SIZE(CM)	N.W/pc (KGS)	G.W.(KGS)	Q'TY(PCS)
Carton	56*43*45	0.3	14.5	36

	CTNS	Q'TY(PCS)	VOLUME(CBM)
20" standard container	256	9216	28
40" standard container	512	18432	56

