



UPSHINE<sup>®</sup>



Technical Application  
Guide for UP-SHINE  
LED Track Light  
UP-TL09-35W

# Introduction



Up-shine track light adopts high lumen CITIZEN COB LEDs with excellent color rendering index to increase the color fidelity of the target illuminated object. Providing excellent heat dissipation, even light output without glare & dark spot. Adjustable lighting orientation with 360 degree in horizontal direction and 300 in vertical direction provided. 1-circuit adapter, 2-circuit adapter, 3-circuit adapter offered for wide choice.

- Up to 70% energy saving compared to standard CFL
- Long lifetime of 40,000 hours
- 24° 38° 60° beam angle
- CCT: 2700K 3000K 4000K 5000K
- No UV/IR light
- Environment friendly, without Mercury or any other hazardous substances

## Application notes

- IP20 for indoor use only
- Professional electrician for installation only
- Switch off before installation
- Do not touch when in use
- Keep away from hot steam and corrosive gas

## Application Areas

It is suitable for supermarket, specialty store, show window, exhibition hall; focus lighting, decorative and background lighting, where attention is focused on subjects to emphasize special visual points.

## Certificate



# Product Information

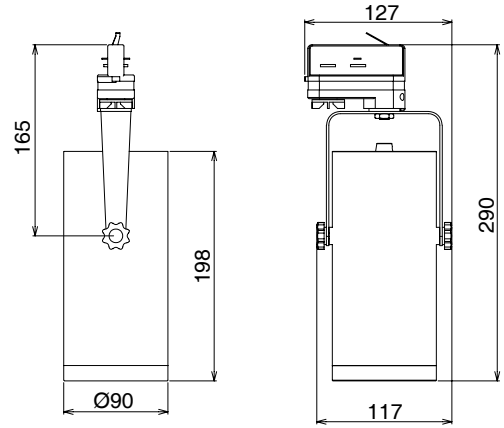

## Technical Specifications

Model	Voltage	Power	Power Factor	Lumen (±5%)	Beam angle	CCT	Lifespan	CRI	Dimmable	Dimension
UP-TL09-35W	AC100-240V	35W	≥0.9	3400	24°/38°/60°	2700K	40000h	≥80	No	Ø90*290mm
UP-TL09-35W	AC100-240V	35W	≥0.9	3450	24°/38°/60°	3000K	40000h	≥80	No	Ø90*290mm
UP-TL09-35W	AC100-240V	35W	≥0.9	3600	24°/38°/60°	4000K	40000h	≥80	No	Ø90*290mm
UP-TL09-35W	AC100-240V	35W	≥0.9	3500	24°/38°/60°	5000K	40000h	≥80	No	Ø90*290mm

## Driver data Sheet

Driver data	Non-dim
Input rated Voltage	AC100-240V
Frequency	50/60HZ
Input Voltage	AC85-265V
Efficiency	≥85%
Total load Wattage	35W±5%
Power Factor	≥0.9
Rated input current	≤0.39A
Full load output Voltage	DC23-38V
Rated output current	820mA
Output current range	820mA±5%
Power tolerance	±5%
Current output tolerance	±5%
Short circuit protection	PASS
Over voltage protection	PASS
Over temperature protection	PASS
Withstand voltage	AC1500V

## Fixture Compatibility

Rated Wattage	Electrical Classification	Ingress Protection	Operating Temp	Operating Humidity	Storage Temp
35W	I	IP20	-20°C~45°C	0~90%	-20°C~65°C

# Spectral Distribution

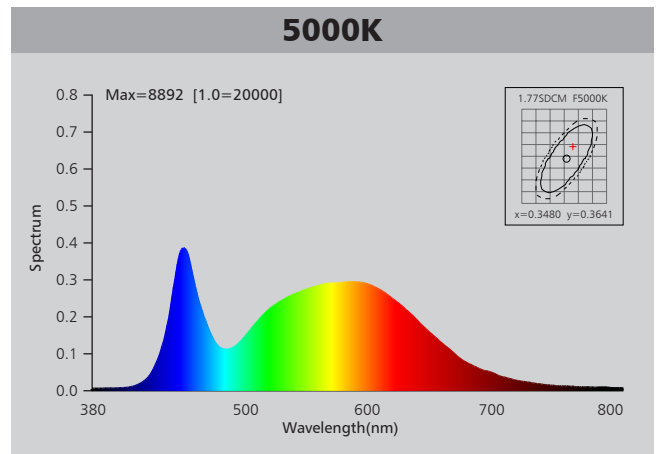
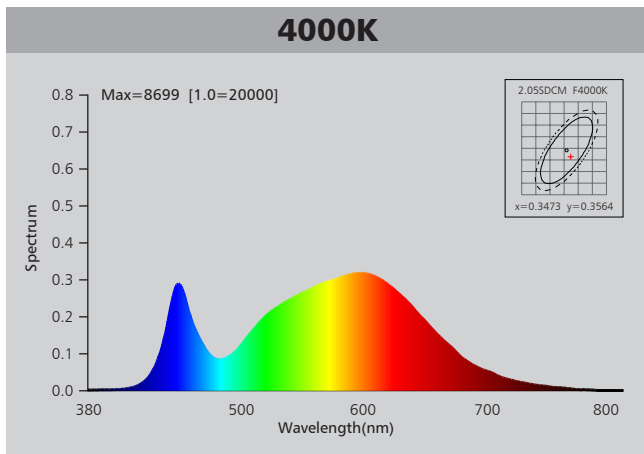
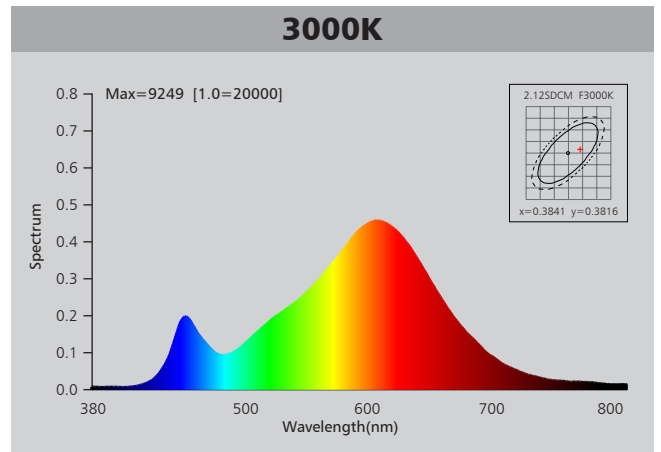
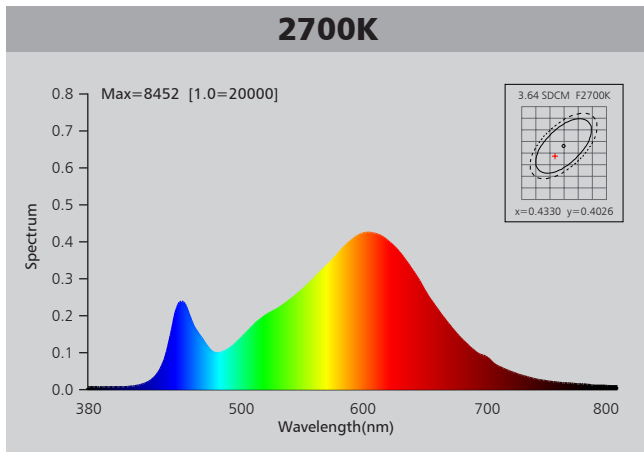

# Photometric Diagram

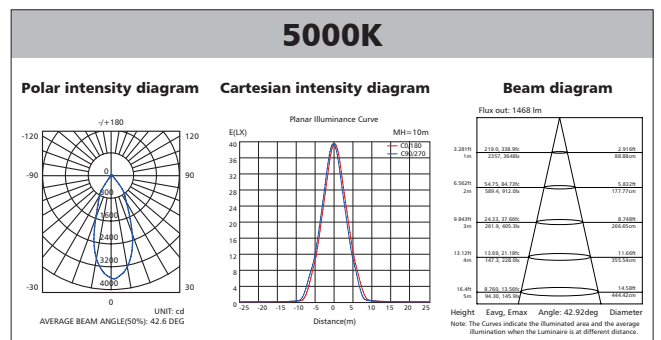
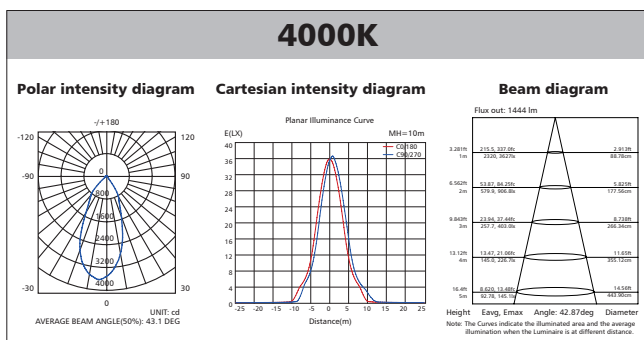
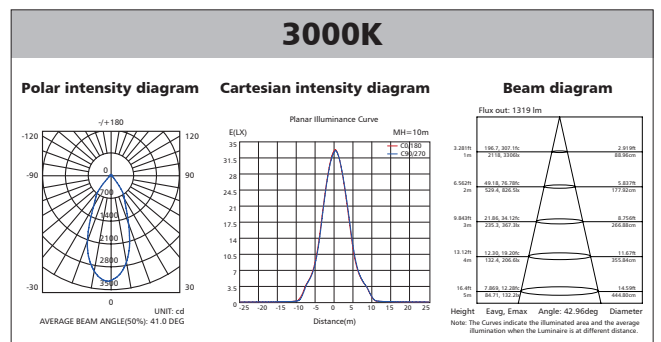
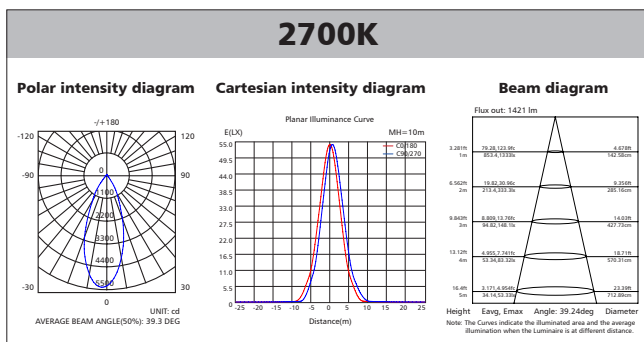

## Polar Diagram Comparison

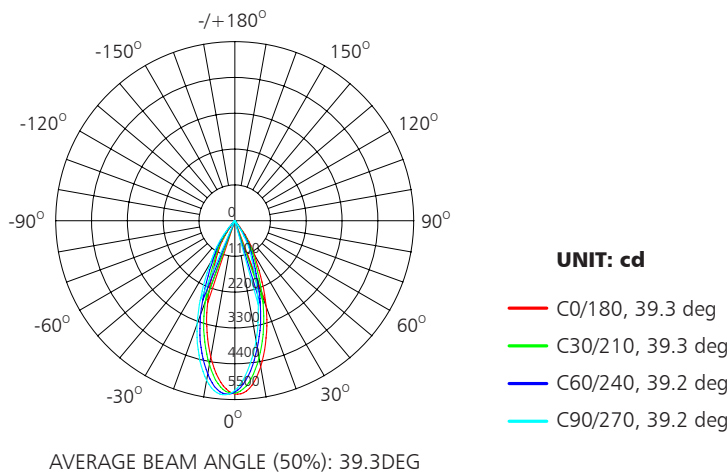

## Driver lifetime & LED light decay rate

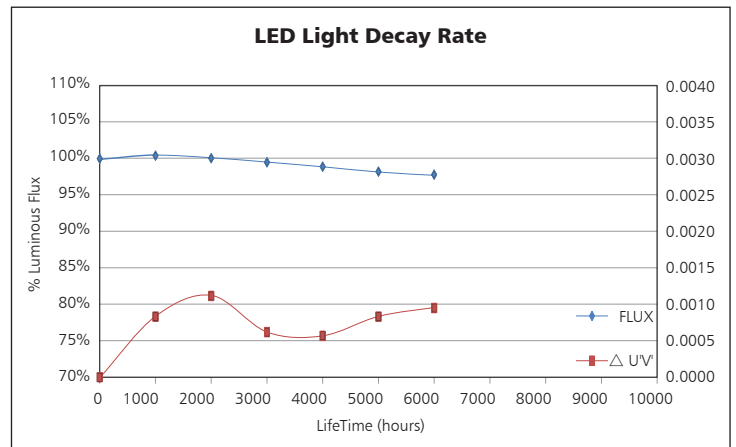
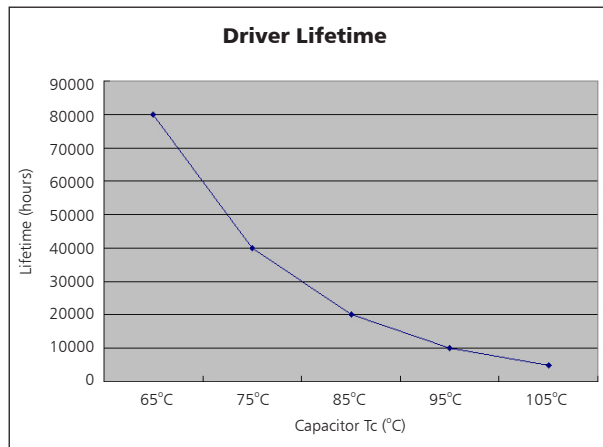

## Temperature

- The testing is operated at 25°C
- The lifetime of capacitor, minimum of 5,000 hours if operated at 105°C, will be doubled whenever the temperature drops 10°C. Working at 75°C or below, the lamp can achieve its maximum lifetime of 40,000 hours.
- The highest withstand temperature of IC, MOS could be 120°C
- The highest withstand temperature of LED junction temperature is 150°C

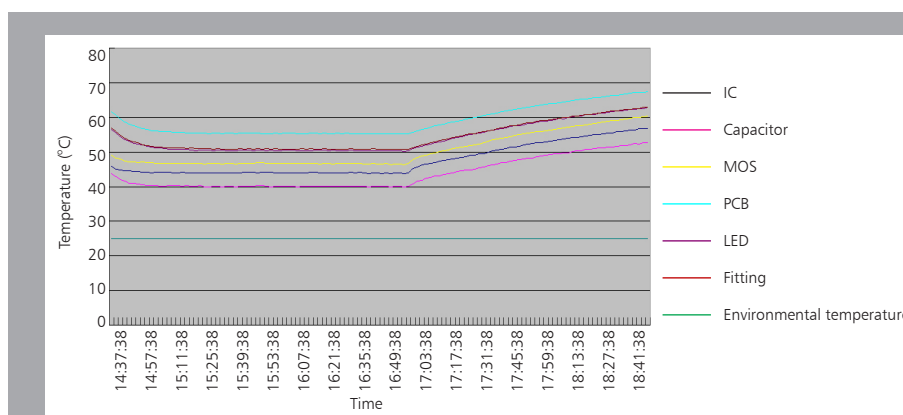

The driver lifespan is based on capacitor working temperature.

## Installation

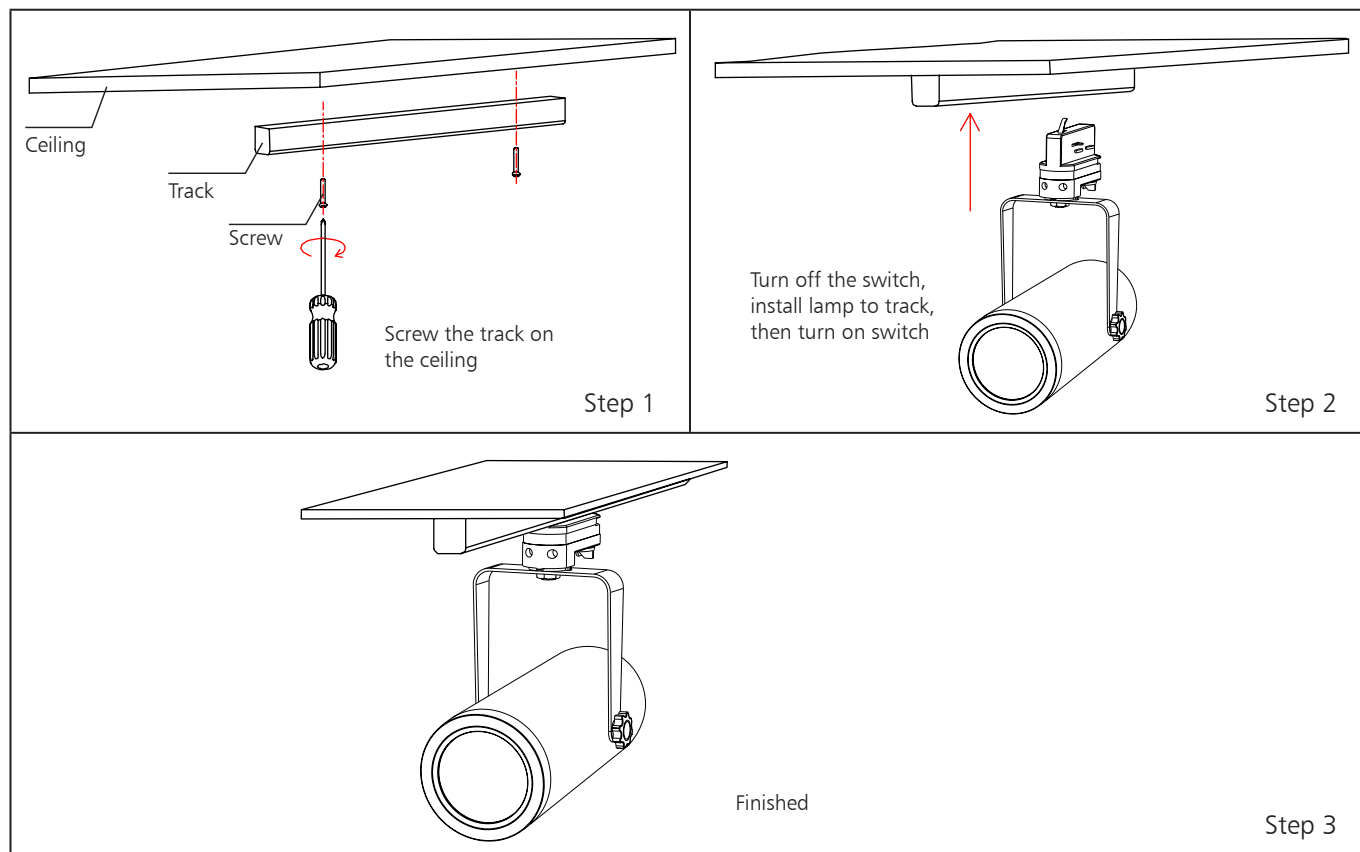

## Packaging Information

	SIZE(CM)	N.W/pc (KGS)	G.W.(KGS)	Q'TY(PCS)
Carton	57.5*24.5*34	1.2	13.5	10

	CTNS	Q'TY(PCS)	VOLUME(CBM)
20" standard container	556	5560	28
40" standard container	1112	11120	56

