

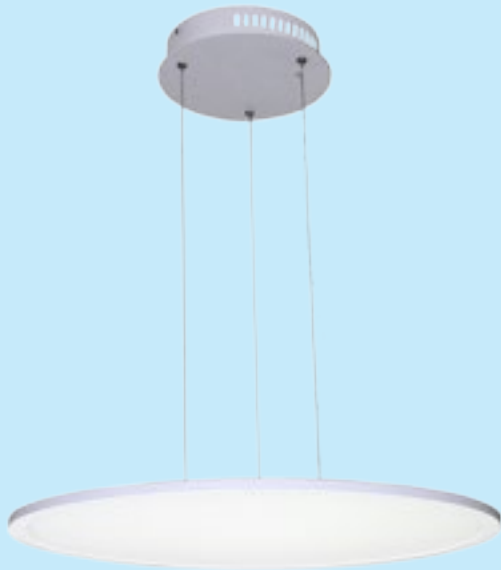

Technical Application Guide for Stylelite LED Pendant Light

UP-PL4012-25W-W

Introduction



Pendant led light acts as a decorative light in most applications. Elegant design creates soft lighting effect, suspended installation with adjustable mounting height, perfect for hotels, restaurant, coffee shop etc. 400mm, 600mm diameter for wide choice.

- Up to 80% energy saving compared to standard CFL
- Long lifetime of 40,000 hours
- 120° wide beam angle
- CCT: 3000K 4000K
5000K 5700K
- No UV/IR light
- Environment friendly, without Mercury or any other hazardous substances

Application notes

- IP40 for indoor use only
- Professional electrician for installation only
- Switch off before installation
- Do not touch when in use
- Keep away from hot steam and corrosive gas

Application Areas

It is widely used for various commercial and residential lighting applications, such as office, hotel, restaurant, home lighting etc.

Certificates



Product Information

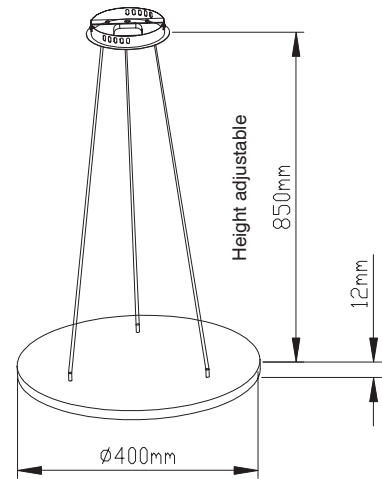

Technical Specifications

Model	Voltage	Power	Power Factor	Lumen (±5%)	Beam angle	CCT	Lifespan	CRI	Dimmable	Dimension
UP-PL4012-25W-W	AC100-240V	25W	≥0.9	2020	120°	3000K	40000h	≥80	No	Ø400*12mm
UP-PL4012-25W-W	AC100-240V	25W	≥0.9	2100	120°	4000K	40000h	≥80	No	Ø400*12mm
UP-PL4012-25W-W	AC100-240V	25W	≥0.9	2150	120°	5000K	40000h	≥80	No	Ø400*12mm
UP-PL4012-25W-W	AC100-240V	25W	≥0.9	2170	120°	5700K	40000h	≥80	No	Ø400*12mm
UP-PL4012-25WD-W	AC200-240V	25W	≥0.9	2000	120°	3000K	40000h	≥80	Yes	Ø400*12mm
UP-PL4012-25WD-W	AC200-240V	25W	≥0.9	2050	120°	4000K	40000h	≥80	Yes	Ø400*12mm
UP-PL4012-25WD-W	AC200-240V	25W	≥0.9	2100	120°	5000K	40000h	≥80	Yes	Ø400*12mm
UP-PL4012-25WD-W	AC200-240V	25W	≥0.9	2120	120°	5700K	40000h	≥80	Yes	Ø400*12mm

Driver data Sheet

Driver data	Dim	Non-dim
Input rated Voltage	AC230V	AC100-240V
Frequency	50Hz	50/60Hz
Input Voltage	AC200-240V	AC85-265V
Efficiency	≥85%	≥86%
Total load Wattage	25W±5%	25W±5%
Power Factor	≥0.9	≥0.9
Rated input current	≤0.12A	≤0.28A
Full load output Voltage	DC35-40V	DC35-40V
Rated output current	580mA	580mA
Output current range	580mA±5%	580mA±5%
Tolerance	±5%	±5%
Current output tolerance	±5%	±5%
Dimming range	8%-100%	—
Dimmer	Triac dimmers	—
Short circuit protection	PASS	PASS
Over voltage protection	PASS	PASS
Over temperature protection	PASS	PASS
Withstand voltage	AC1500V	AC1500V

Fixture Compatibility

Rated Wattage	Electrical Classification	Ingress Protection	Operating Temp	Operating Humidity	Storage Temp
25W	I	IP40	-20°C~45°C	0~90%	-20°C~65°C

Spectral Distribution

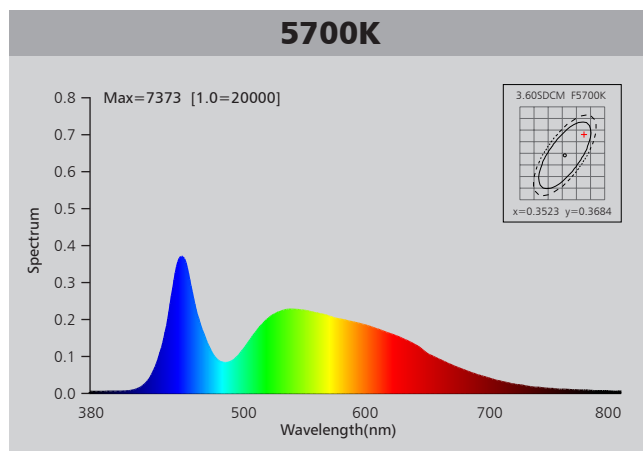
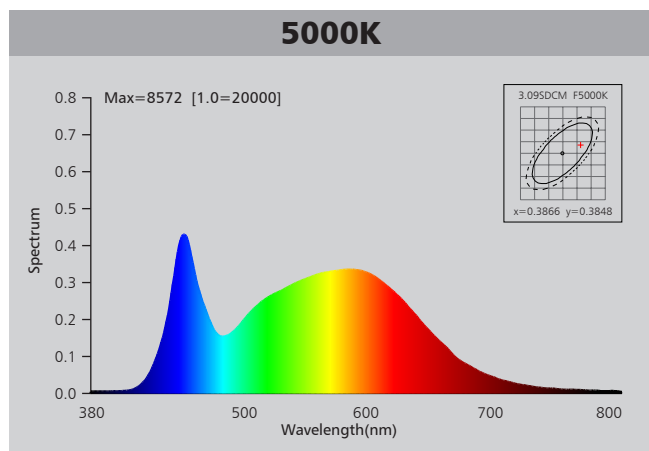
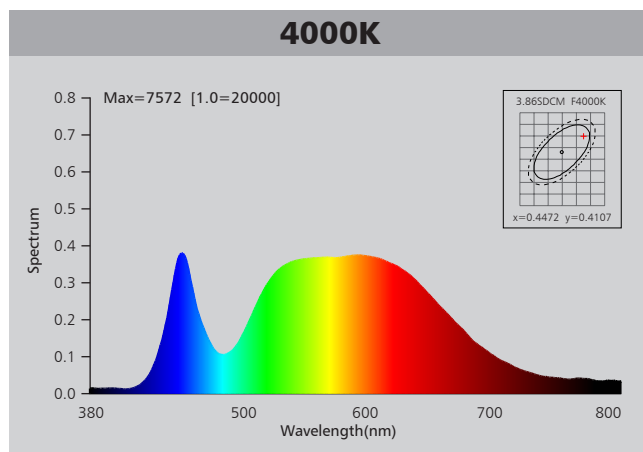
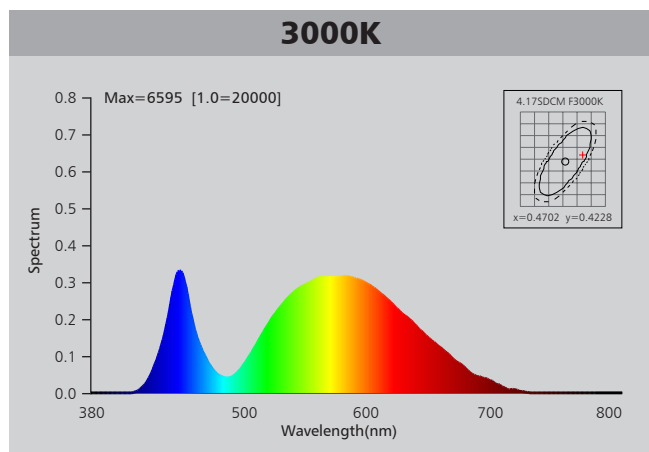

Photometric Diagram

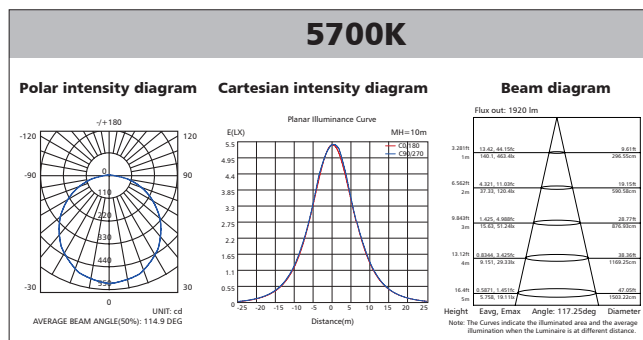
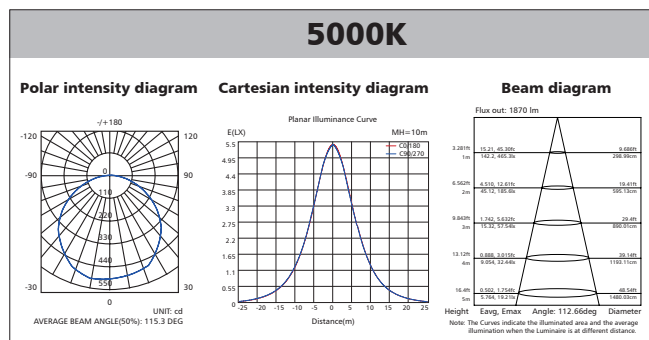
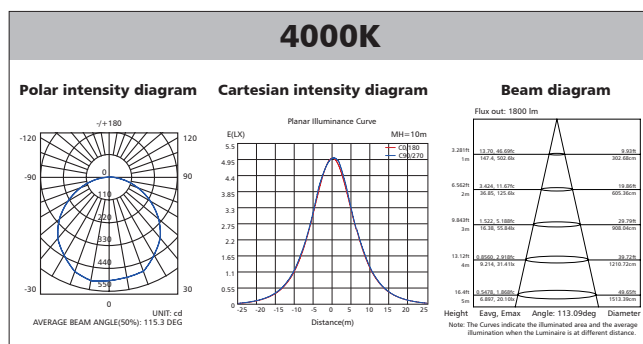
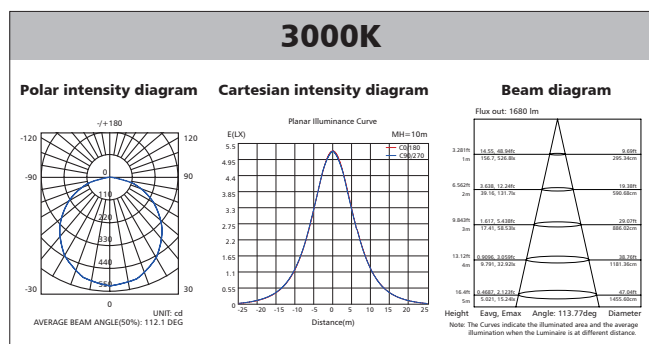

Polar Diagram Comparison

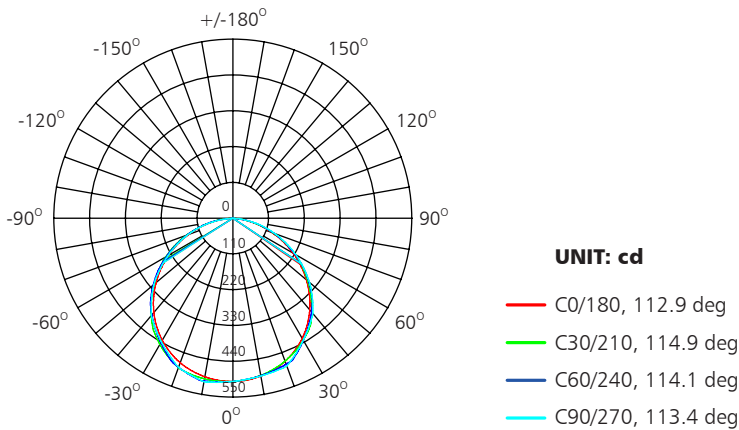

AVERAGE BEAM ANGLE (50%): 115.4DEG



Driver lifetime & LED lifetime

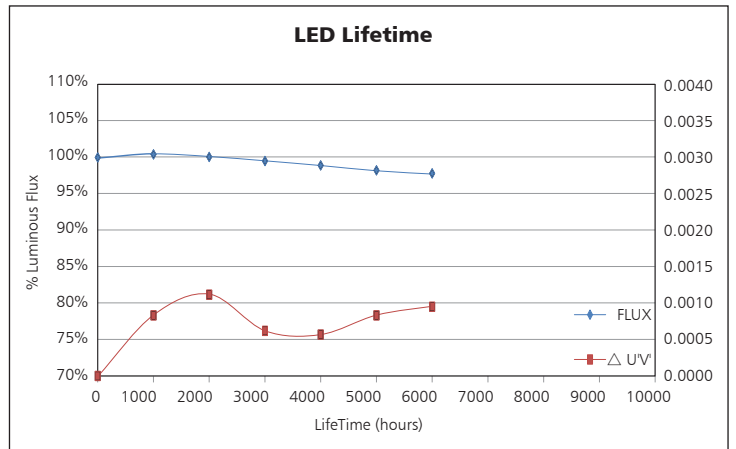
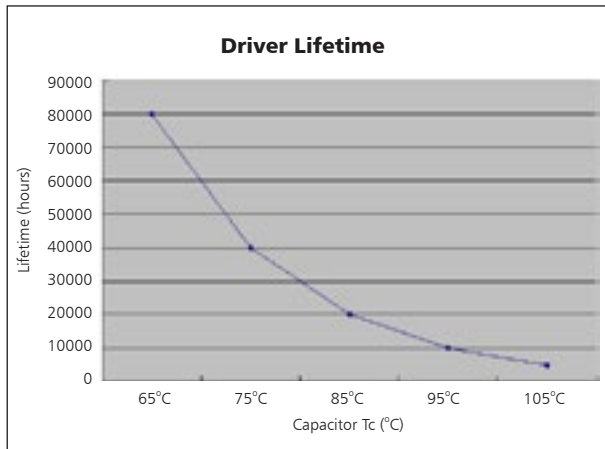

Temperature

- The testing is operated at 25°C
- The lifetime of capacitor, minimum of 5,000 hours if operated at 105°C, will be doubled whenever the temperature drops 10°C
- The highest withstand temperature of IC, MOS could be 120°C
- The highest withstand temperature of LED junction temperature is 150°C

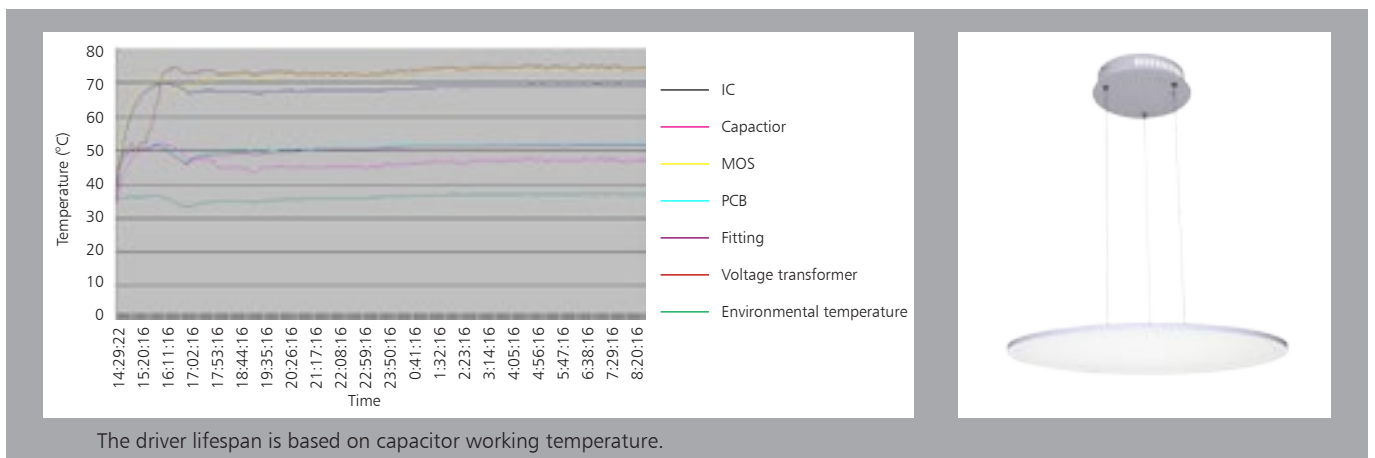

Installation

Wooden ceiling:

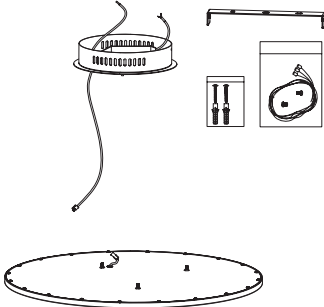
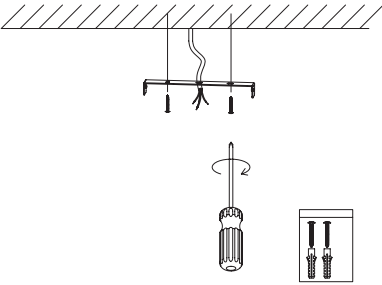
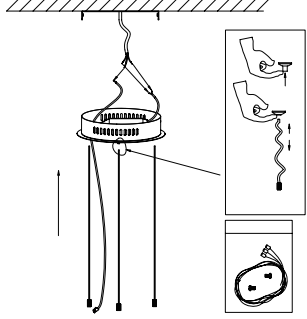
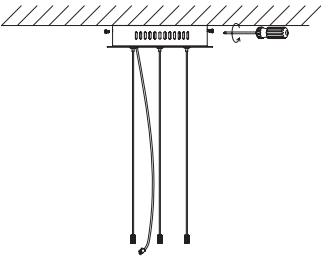
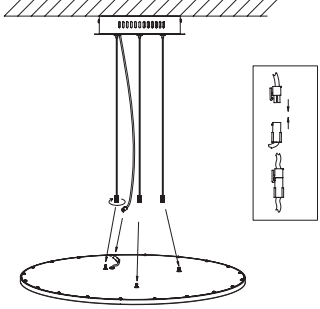
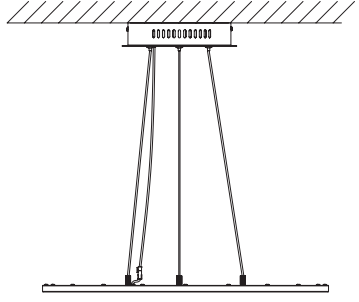
 <p>1. Unbox panel light and accessory pack.</p>	 <p>2. Switch off, fix bracket into ceiling with screw.</p>	 <p>3. Insert the hanging wire into wall mount bracket; connect L/N/E to mains supply.</p>
 <p>4. Fix the wall mount bracket into ceiling by screw.</p>	 <p>5. Hang panel to suspending rope and connect the DC connector</p>	 <p>6. Adjust the length of hanging wire to proper height, Restore the power and switch on.</p>

Concrete ceiling:

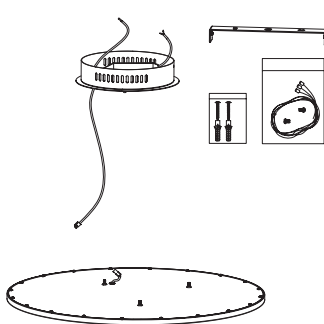
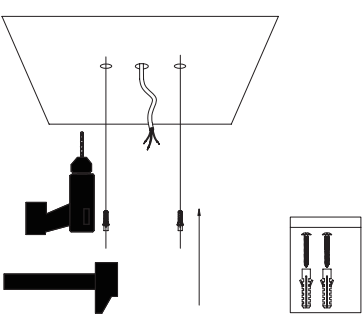
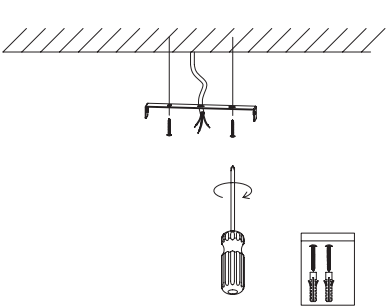
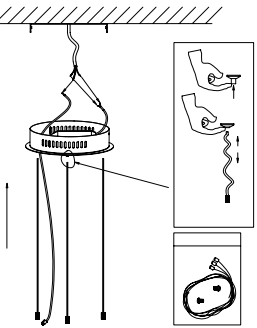
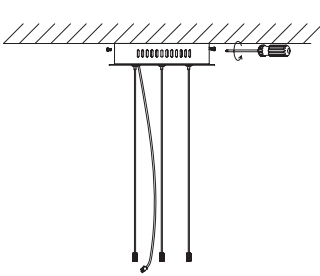
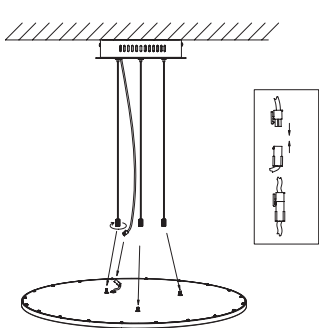
 <p>1. Unbox panel light and accessory pack</p>	 <p>2. Power off, Punch holes and knock the plastic anchor into ceiling</p>	 <p>3. Fix bracket into ceiling with screw.</p>
 <p>4. Insert the hanging wire into wall mount bracket; connect L/N/E to mains supply.</p>	 <p>5. Fix the wall mount bracket into ceiling by screw.</p>	 <p>6. Hang panel to suspending rope and connect the DC connector</p>

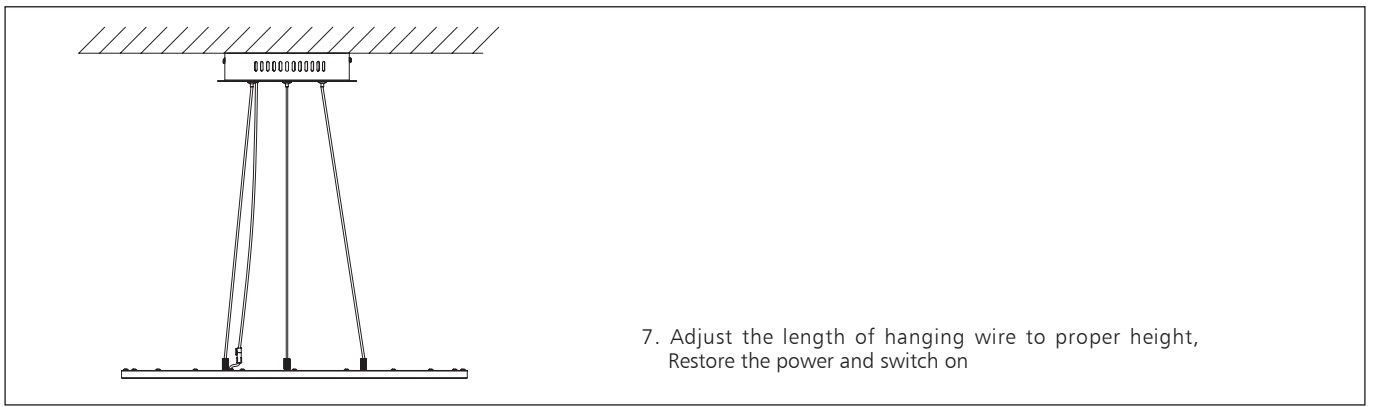

Packaging Information

	SIZE(CM)	N.W/pc (KGS)	G.W.(KGS)	Q'TY(PCS)
Carton	45.5*21.5*65	3.1	13.3	4

	CTNS	Q'TY(PCS)	VOLUME(CBM)
20" standard container	433	1732	28
40" standard container	866	3464	56

