



Up-shine[®] Lighting



Technical Application
Guide for UP SHINE LED
Frameless Panel Light
UP-PL6060-36W-P

Introduction



Frameless panel is an improved version compared to regular panels. They are of high lumen output, high CRI > 80, top branded driver with stable working performance. Dimmable version comes with triac dim, 0-10V dim, DALI dim, it shares great popularity by perfect dimming range and great compatibility with worldwide dimmers. The Frameless structural design makes it special and elegant. 5mm thickness diffuser with extremely even light output provides high quality lighting effect.

- Up to 80% energy saving compared to standard CFL
- Long lifetime of 40,000 hours
- Dimmable when using triac dimmer
- 120° wide beam angle
- CCT: 3000K 4000K
5000K 5700K
- No UV/IR light
- Environment friendly, without Mercury or any other hazardous substances

Application notes

- IP40 for indoor use
- Professional electrician for installation only
- Switch off before installation
- Do not touch when in use
- Keep away from hot steam and corrosive gas

Application Areas

Widely used for various commercial lighting and residential lighting applications, such as office, shopping mall, hotel, restaurant, hospital, home lighting etc.

Certificates



RoHS



Product Information

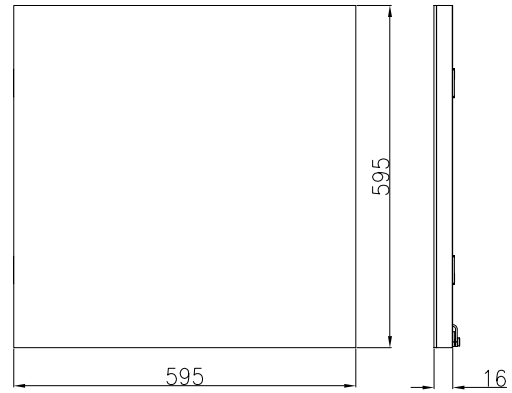

Technical Specifications

Model	Voltage	Power	Power Factor	Lumen (±5%)	Beam angle	CCT	Lifespan	CRI	Dimmable	Dimension
UP-PL6060-36W-P	AC100-240V	36W	≥0.9	2700	120°	3000K	40000h	≥80	No	595*595*16mm
UP-PL6060-36W-P	AC100-240V	36W	≥0.9	2800	120°	4000K	40000h	≥80	No	595*595*16mm
UP-PL6060-36W-P	AC100-240V	36W	≥0.9	2880	120°	5000K	40000h	≥80	No	595*595*16mm
UP-PL6060-36W-P	AC100-240V	36W	≥0.9	2900	120°	5700K	40000h	≥80	No	595*595*16mm

Driver data Sheet

Driver data	Non-dim
Input rated Voltage	AC100-240V
Frequency	50/60Hz
Input Voltage	AC85-265V
Efficiency	≥86%
Total load Wattage	36W±5%
Power Factor	≥0.9
Rated input current	≤0.4A
Full load output Voltage	DC35-50V
Rated output current	700mA
Output current range	700mA±5%
Power tolerance	±5%
Current output tolerance	±5%
Dimming range	—
Dimmer	—
Short circuit protection	PASS
Over voltage protection	PASS
Over temperature protection	PASS
Withstand voltage	AC3750V

Fixture Compatibility

Rated Wattage	Electrical Classification	Ingress Protection	Operating Temp	Operating Humidity	Storage Temp
36W	II	IP40	-20°C~45°C	0~90%	-20°C~65°C

Spectral Distribution

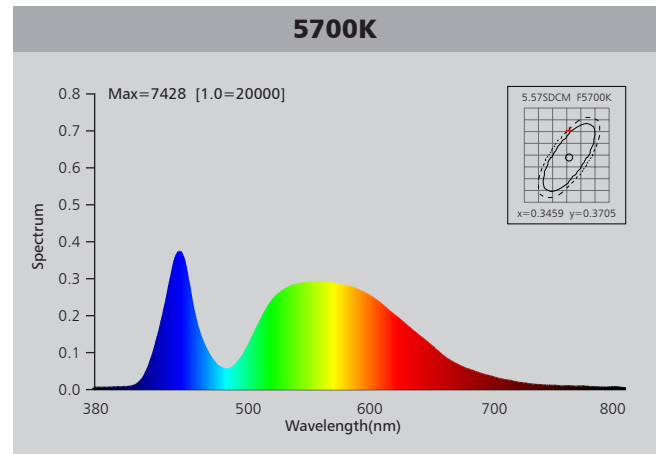
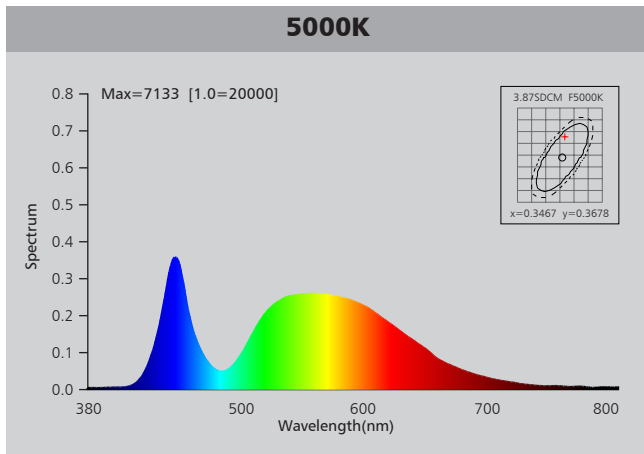
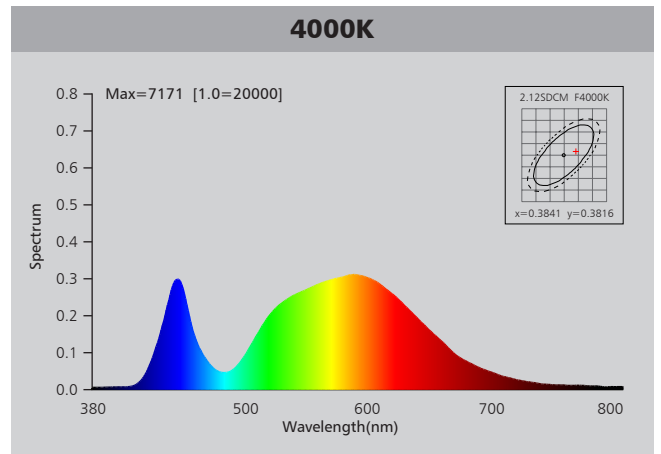
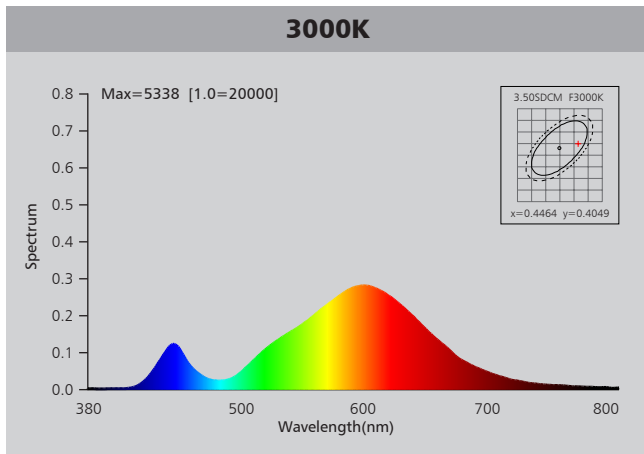

Photometric Diagram

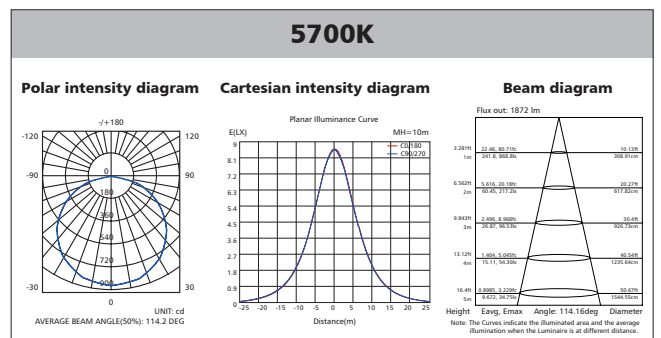
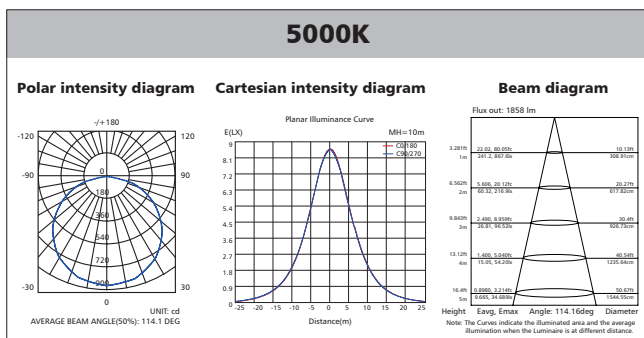
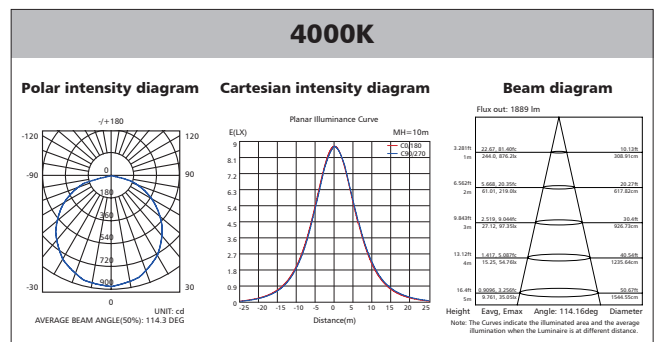
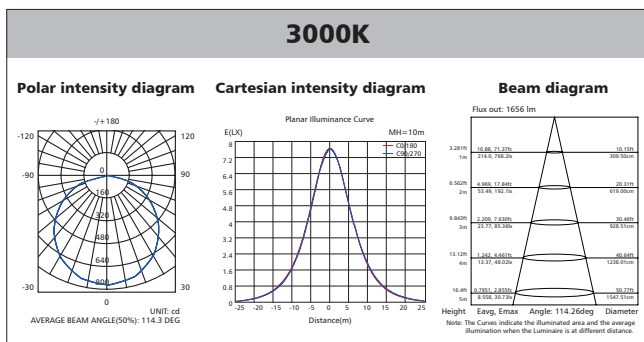

Polar Diagram Comparison

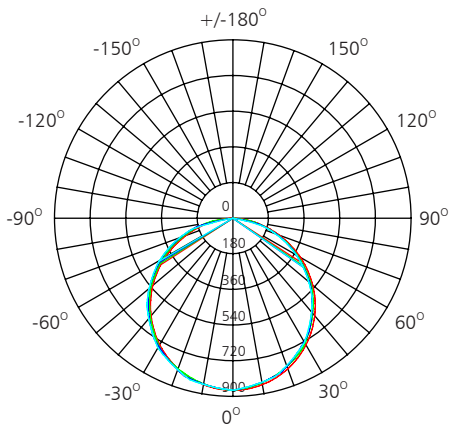

- UNIT: cd**
- C0/180, 114.2 deg
 - C30/210, 113.8 deg
 - C60/240, 114.2 deg
 - C90/270, 114.6 deg

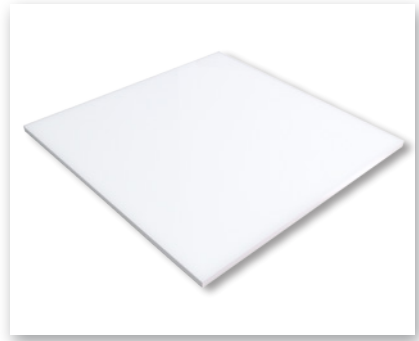

AVERAGE BEAM ANGLE (50%): 114.2DEG

Driver lifetime & LED light decay rate

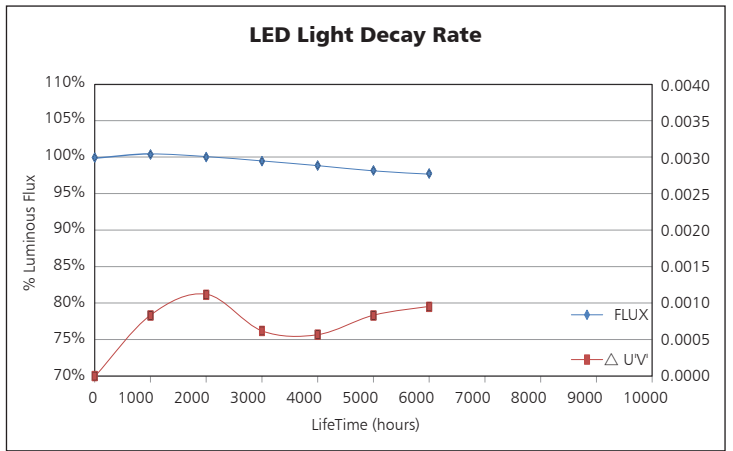
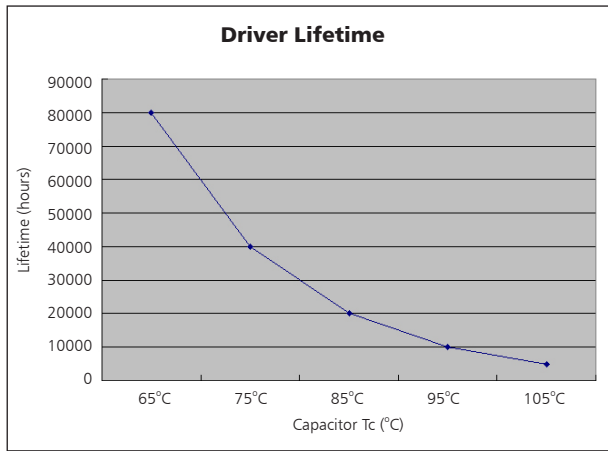

Temperature

- The testing is operated at 25°C
- The lifetime of capacitor, minimum of 5,000 hours if operated at 105°C, will be doubled whenever the temperature drops 10°C
- The highest withstand temperature of IC, MOS could be 120°C
- The highest withstand temperature of LED junction temperature is 150°C

The driver lifespan is based on capacitor working temperature.

Installation

1. Recessed into ceiling

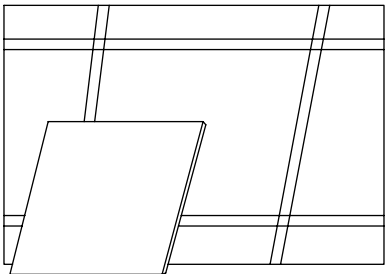
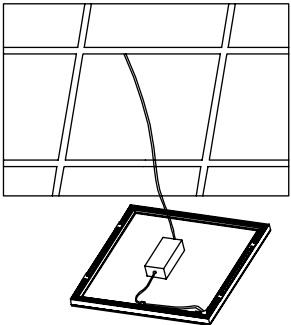
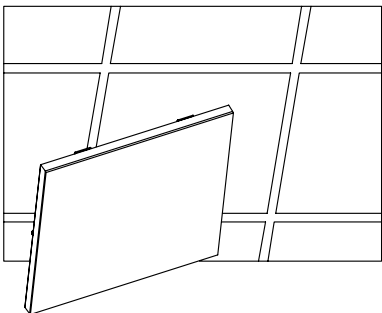
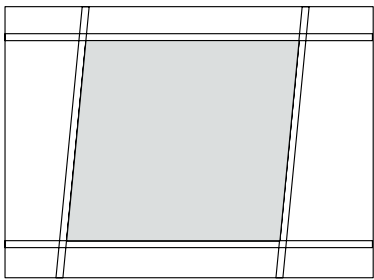
<p>1. Remove ceiling plaster slab.</p> 	<p>2. Connect power supply.</p> 
<p>3. Fix the panel light into right place.</p> 	<p>4. Stabilize the panel.</p> 

2. Suspending

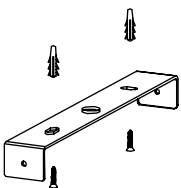
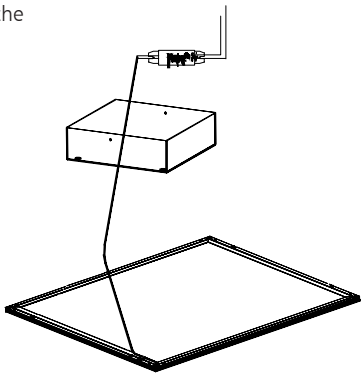
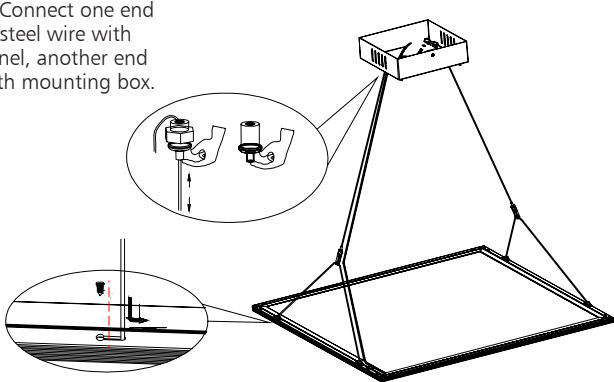
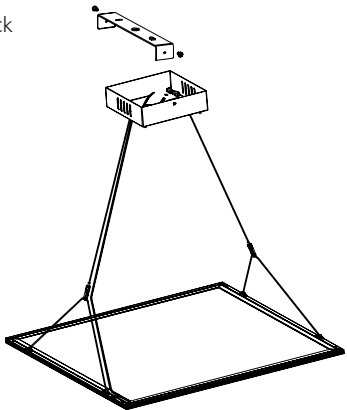
<p>1. Fastening the bracket on the ceiling with plastic anchor and screw.</p> 	<p>2. Put the DC line through the mounting box and connect the power supply.</p> 
<p>3. Connect one end of steel wire with panel, another end with mounting box.</p> 	<p>4. Hang the mounting box back to the bracket.</p> 

3. Suspending

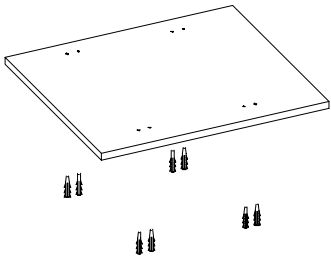
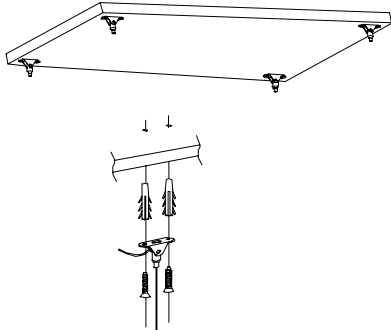
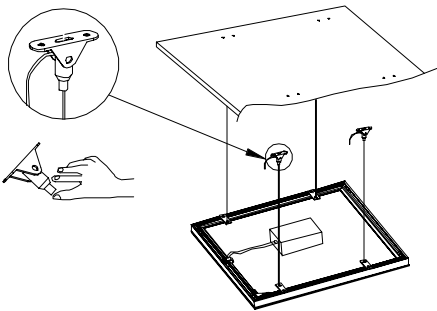
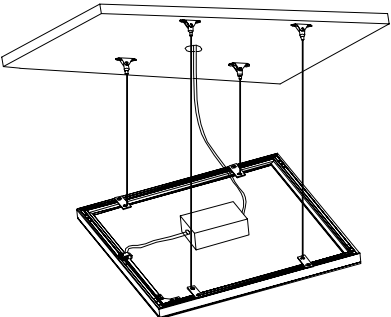
<p>1. Fix the plastic anchoring into suitable place on the ceiling</p> 	<p>2. Use the tapping screw fix the installation mount with the plastic anchoring on the ceiling</p> 
<p>3. Let the steel wire with knot end through clips's hole on panel. Fix the wire's another side with the installation mount.</p> 	<p>4. Adjust the steel wire to a suitable length. Connect with power supply. Turn on the LED panel light.</p> 

Packaging Information

	SIZE(CM)	N.W/pc (KGS)	G.W.(KGS)	Q'TY(PCS)
Carton	66.5*21*73	5.1	24.5	4

	CTNS	Q'TY(PCS)	VOLUME(CBM)
20" standard container	250	1000	28
40" standard container	500	2000	56

