



Up-shine[®] Lighting



Technical Application Guide for UP-SHINE LED Cylinder

UP-PD02B-10W

Introduction



PD02 whole lamp adopts straightforward design with stylish appearance, easy to install, simple and generous, paying more attention to leisure and comfort. It gives space a clear and lively feelings. The color of surface ring is replaceable, which could create diversified light atmosphere according to different environment.

Suspension wire adopts pull-resistance triple-core wire wrapped with woven cloth. It enhances the tensile strength and easily install compared to steel wire. The lamp adopts high quality reflector which has good reflective rate and light output > 86%. AL6063 Aluminum radiator in sand blast oxidation treatment provides excellent heat dissipation and corrosion resistance. LEDs are high lumen COB chip with CRI>80. Built-in driver is independent and replaceable, which is friendly maintenance. PF>0.9, THD<20%, passed EMC test with strong anti-jamming capability. Besides, it possesses short-circuit protection and overvoltage protection function, showing high safety performance.

- Up to 70% energy saving compared to standard CFL
- Long lifetime of 40,000 hours
- 15°/24°/36° wide beam angle
- CCT: 2700K 3000K
4000K 5000K
- No UV/IR light
- Environment friendly, without Mercury or any other hazardous substances

Application notes

- IP20 for indoor use only
- Professional electrician for installation only
- Switch off before installation
- Do not touch when in use
- Keep away from hot steam and corrosive gas

Application Areas

Applicable for residential lighting in bedroom, living room, corridor etc, also suitable for commercial lighting in office, hotel, restaurant etc.

Certificate

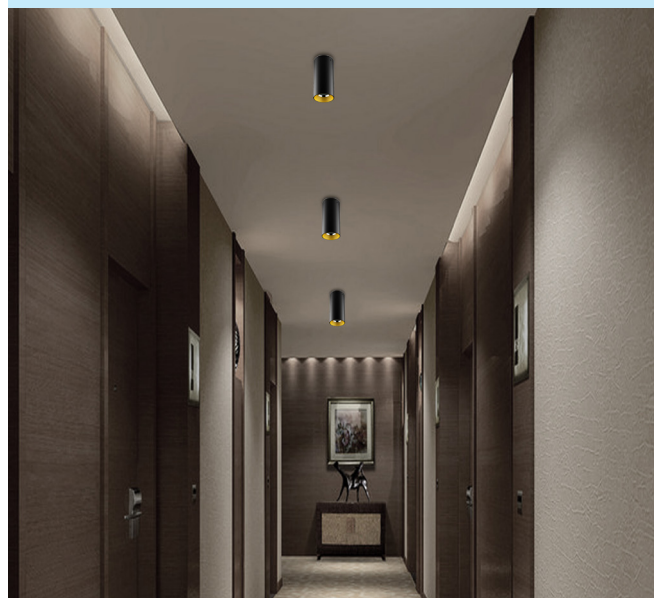

Product Information

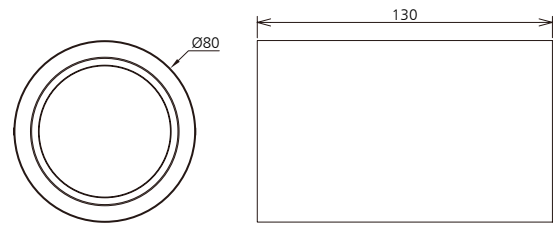

Technical Specifications

Model	Voltage	Power	Power Factor	Lumen (±5%)	Beam angle	CCT	Lifespan	CRI	Dimmable	Dimension
UP-PD02B-10W	AC100-240V	10W	≥0.9	850	15°/24°/36°	2700K	40000h	≥80	No	Ø80*130mm
UP-PD02B-10W	AC100-240V	10W	≥0.9	860	15°/24°/36°	3000K	40000h	≥80	No	Ø80*130mm
UP-PD02B-10W	AC100-240V	10W	≥0.9	900	15°/24°/36°	4000K	40000h	≥80	No	Ø80*130mm
UP-PD02B-10W	AC100-240V	10W	≥0.9	870	15°/24°/36°	5000K	40000h	≥80	No	Ø80*130mm
UP-PD02B-10W-D	AC230V	10W	≥0.9	810	15°/24°/36°	2700K	40000h	≥80	Yes	Ø80*130mm
UP-PD02B-10W-D	AC230V	10W	≥0.9	820	15°/24°/36°	3000K	40000h	≥80	Yes	Ø80*130mm
UP-PD02B-10W-D	AC230V	10W	≥0.9	855	15°/24°/36°	4000K	40000h	≥80	Yes	Ø80*130mm
UP-PD02B-10W-D	AC230V	10W	≥0.9	830	15°/24°/36°	5000K	40000h	≥80	Yes	Ø80*130mm

Driver data Sheet

Driver data	DIM	Non dim
Input rated Voltage	AC230V	AC100-240V
Frequency	50Hz	50/60Hz
Input Voltage	AC220-240V	AC85-265V
Efficiency	≥78%	≥88%
Total load Wattage	10W±0.5W	10W±0.5W
Power Factor	≥0.9	≥0.9
Rated input current	≤0.05A	≤0.12A
Full load output Voltage	DC60-75V	DC60-75V
Rated output current	120mA	120mA
Output current range	120mA±5%	120mA±5%
Power tolerance	±5%	±5%
Current output tolerance	±5%	±5%
Dimming range	8%-100%	—
Dimmer	Triac dimmers	—
Short circuit protection	PASS	PASS
Over voltage protection	PASS	PASS
Over temperature protection	PASS	PASS
Withstand voltage	—	—

Fixture Compatibility

Rated Wattage	Electrical Classification	Ingress Protection	Operating Temp	Operating Humidity	Storage Temp
10W	I	IP20	-20°C~45°C	0~90%	-20°C~65°C

Spectral Distribution

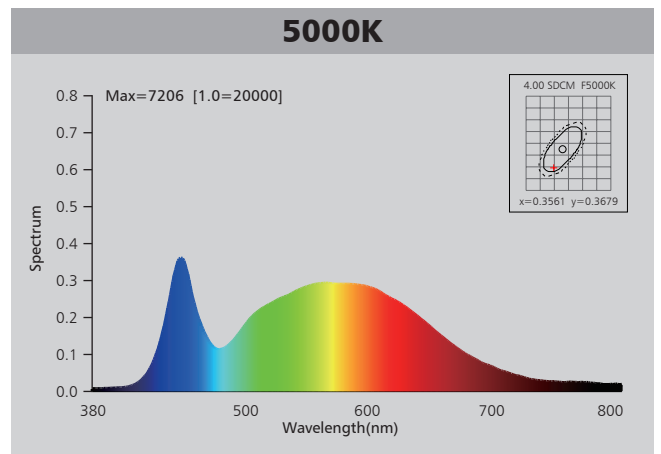
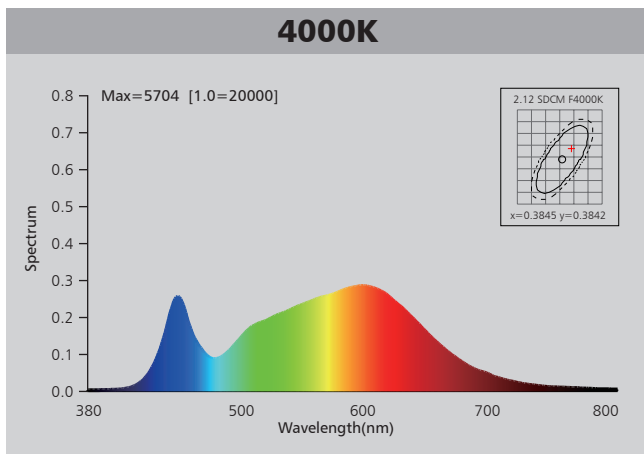
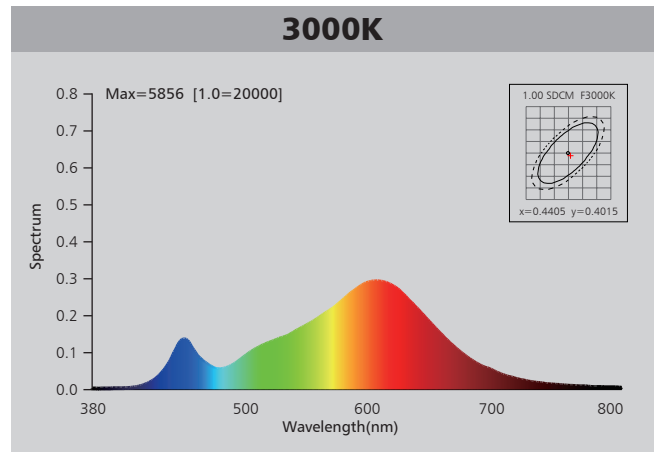
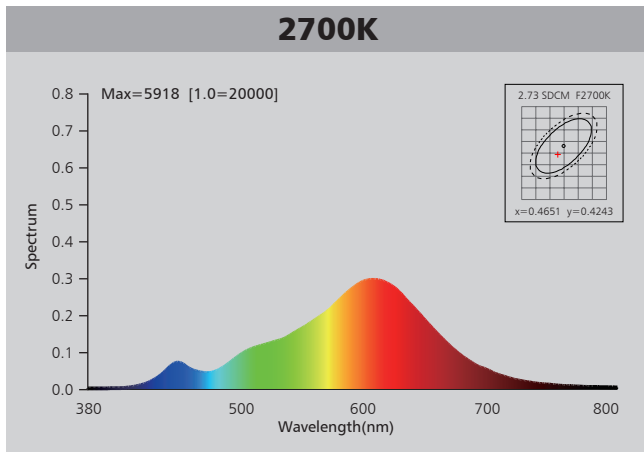

Photometric Diagram

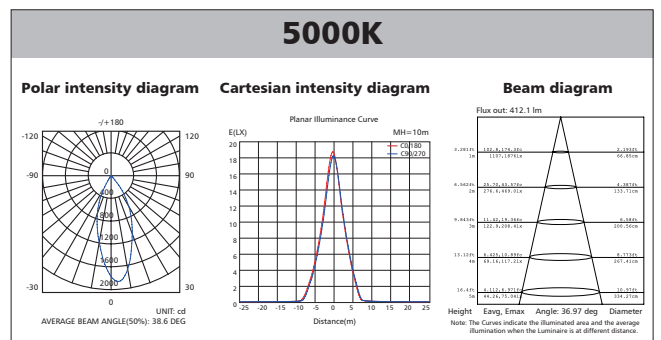
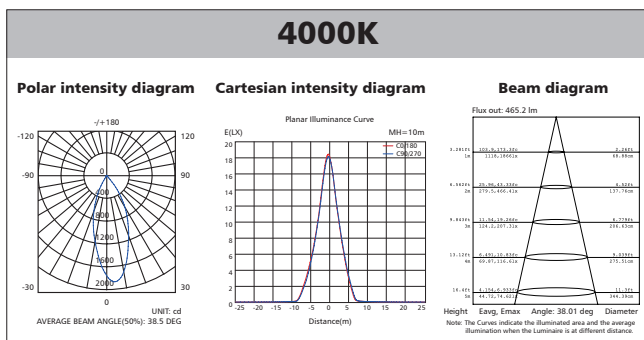
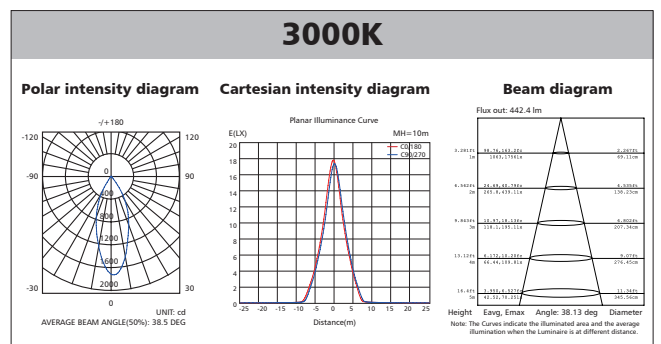
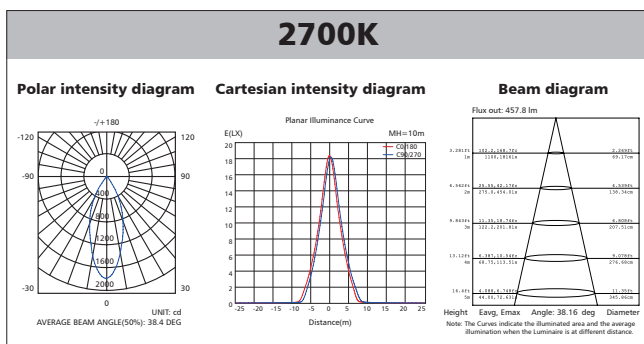

Polar Diagram Comparison

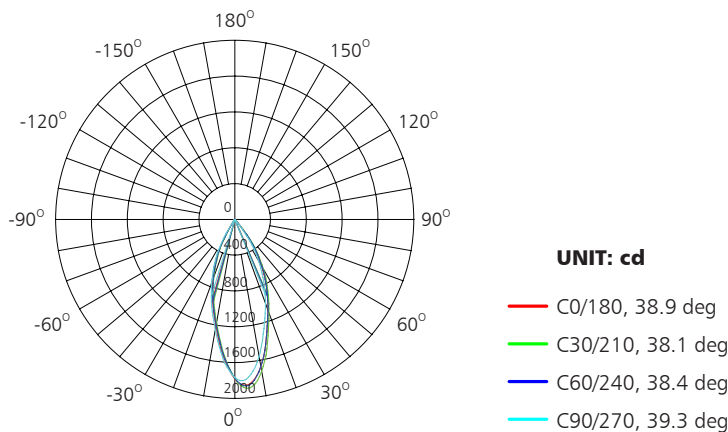

AVERAGE BEAM ANGLE (50%): 38.6DEG



Driver lifetime & LED light decay rate

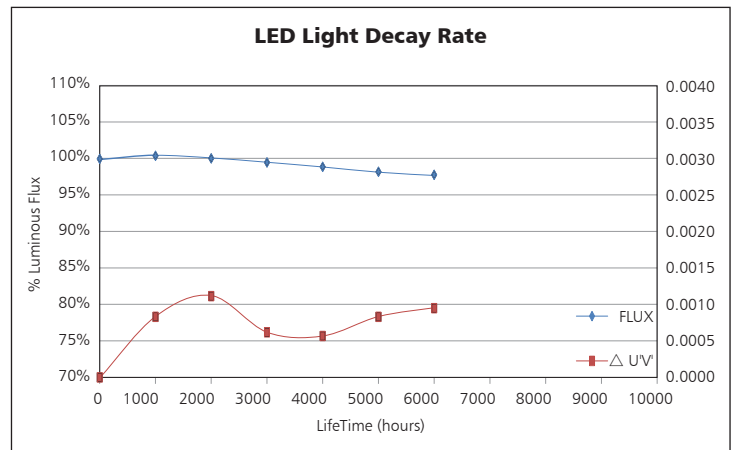
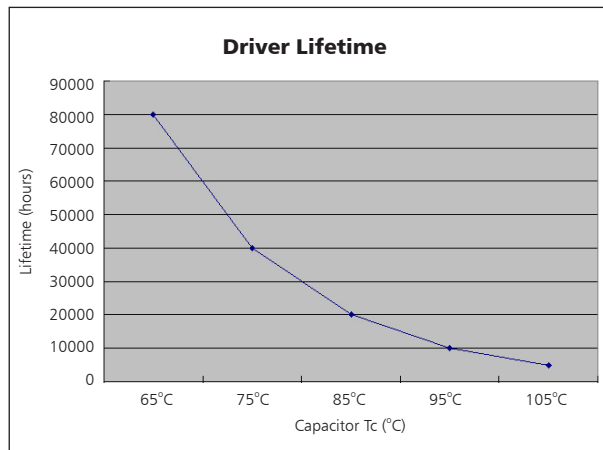

Temperature

- The testing is operated at 25°C
- The lifetime of capacitor, minimum of 5,000 hours if operated at 105°C, will be doubled whenever the temperature drops 10°C
- The highest withstand temperature of IC, MOS could be 120°C
- The highest withstand temperature of LED junction temperature is 150°C

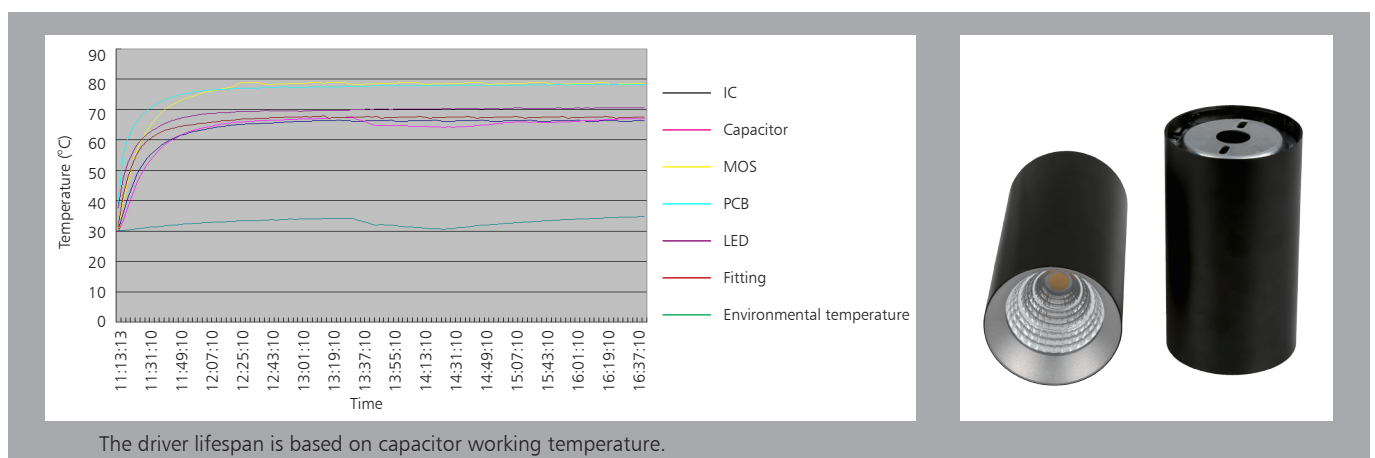

Installation

1

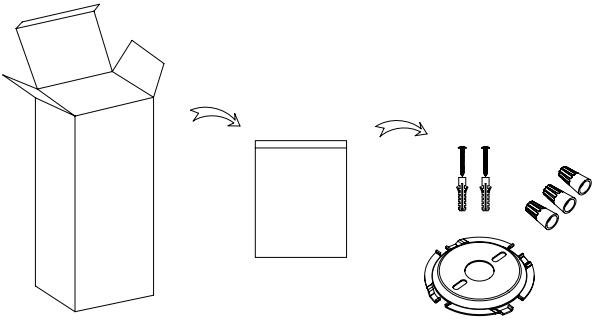

Take out the accessories from accessory box.

2

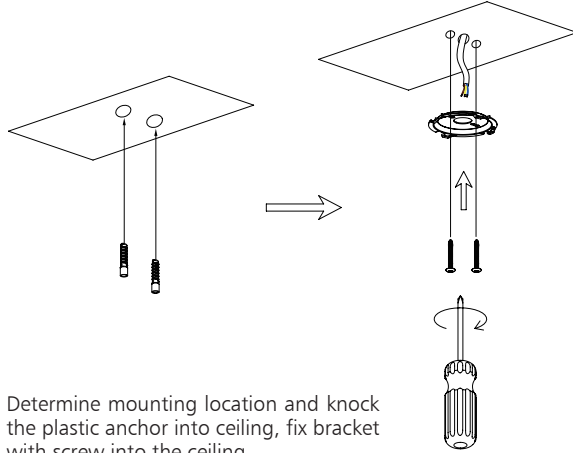

Determine mounting location and knock the plastic anchor into ceiling, fix bracket with screw into the ceiling.

3

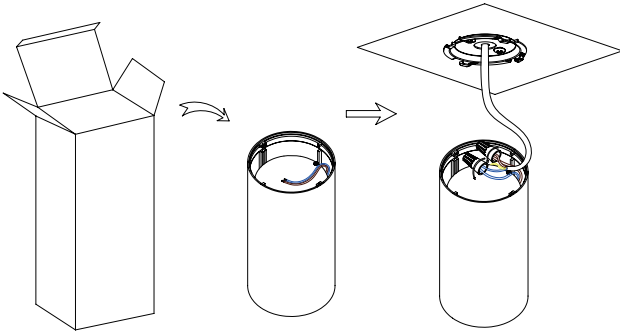

Connect the corresponding polarities between the wire on the ceiling and input wire by screw terminal.

4

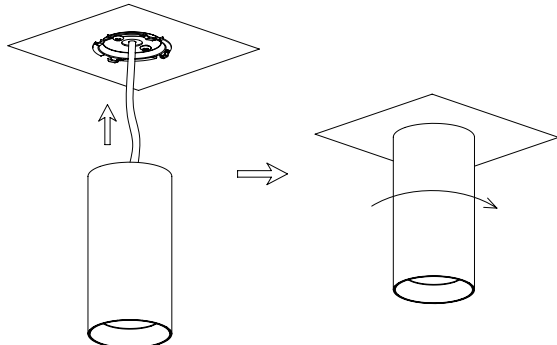

After proper alignment and adjustment between lamp and mounting plate, then rotate the lamp clockwise until it is stuck firmly by mounting plate.

Packaging Information

	SIZE(CM)	N.W/pc (KGS)	G.W.(KGS)	Q'TY(PCS)
Carton	36.5*28*31	0.5	12.2	24

	CTNS	Q'TY(PCS)	VOLUME(CBM)
20" standard container	856	20544	28
40" standard container	1712	41088	56

