



Up-shine<sup>®</sup> Lighting



# Technical Application Guide for UP-SHINE LED Downlight

UP-DL62-3-10W

# Introduction

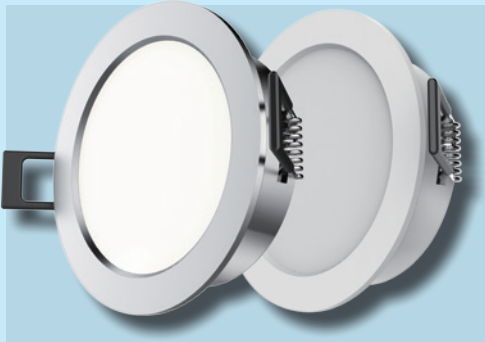

Up-shine SMD LED Down light adopts high lumen SMD LED, PMMA diffuser with even light output. White, silver, chrome surface treatment are available for customer's preference.

Triac dimmable, 0-10V dimmable and DALI dimmable version share great popularity by excellent dimming effect.

- Up to 70% energy saving compared to standard CFL
- Long lifetime of 40,000 hours
- Triac dim, 0-10V dim
- 90° wide beam angle
- Ø90-95mm cutout
- CCT: 3000K 4000K  
5000K 6000K
- No UV/IR light
- Environment friendly, without Mercury or any other hazardous substances

## Application notes

- IP40 for indoor use only
- Professional electrician for installation only
- Switch off before installation
- Do not touch when in use
- Keep away from hot steam and corrosive gas

## Application Areas

It is designed for general lighting applications in office, supermarket, shop, school, hotel, etc. It is also widely used for public areas, such as stairway, lobby, reception, corridors etc.

## Certificate



# Product Information

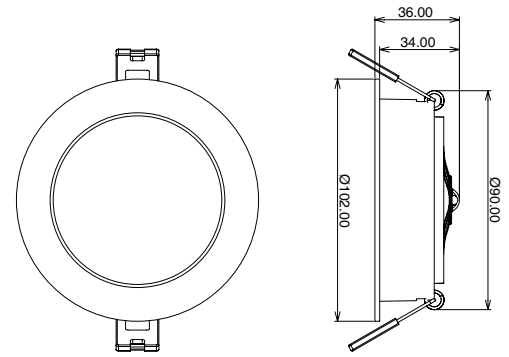

## Technical Specifications

Model	Voltage	Power	Power Factor	Lumen (±5%)	Beam angle	CCT	Lifespan	CRI	Dimmable	Dimension
UP-DL62-3-10W	AC100-240V	10W	≥0.85	720	90°	3000K	40000h	≥80	No	Ø102*36mm cutout Ø90-95mm
UP-DL62-3-10W	AC100-240V	10W	≥0.85	750	90°	4000K	40000h	≥80	No	Ø102*36mm cutout Ø90-95mm
UP-DL62-3-10W	AC100-240V	10W	≥0.85	760	90°	5000K	40000h	≥80	No	Ø102*36mm cutout Ø90-95mm
UP-DL62-3-10W	AC100-240V	10W	≥0.85	770	90°	6000K	40000h	≥80	No	Ø102*36mm cutout Ø90-95mm
UP-DL62-3-10W-D	AC230V	10W	≥0.9	690	90°	3000K	40000h	≥80	Yes	Ø102*36mm cutout Ø90-95mm
UP-DL62-3-10W-D	AC230V	10W	≥0.9	710	90°	4000K	40000h	≥80	Yes	Ø102*36mm cutout Ø90-95mm
UP-DL62-3-10W-D	AC230V	10W	≥0.9	730	90°	5000K	40000h	≥80	Yes	Ø102*36mm cutout Ø90-95mm
UP-DL62-3-10W-D	AC230V	10W	≥0.9	740	90°	6000K	40000h	≥80	Yes	Ø102*36mm cutout Ø90-95mm

## Driver data Sheet

Driver data	DIM	Non dim
Input rated Voltage	AC230V	AC230V
Frequency	50Hz	50Hz
Input Voltage	AC200-240V	AC200-240V
Efficiency	≥72%	≥83%
Total load Wattage	10W±1W	10W±1W
Power Factor	≥0.9	≥0.85
Rated input current	≤0.046A	≤0.05A
Full load output Voltage	DC23-33V	DC23-33V
Rated output current	270mA	300mA
Output current range	270mA±5%	300mA±5%
Power tolerance	±5%	±5%
Current output tolerance	±5%	±5%
Dimming range	8%-100%	——
Dimmer	Triac dimmers	——
Short circuit protection	PASS	PASS
Over voltage protection	PASS	PASS
Over temperature protection	PASS	PASS
Withstand voltage	AC3750V	AC3750V

## Fixture Compatibility

Rated Wattage	Electrical Classification	Ingress Protection	Operating Temp	Operating Humidity	Storage Temp
10W	II	IP40	-20°C~45°C	0~90%	-20°C~65°C

# Spectral Distribution

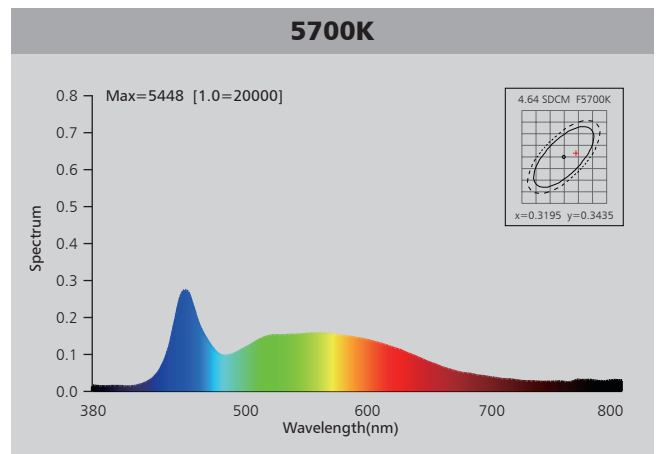
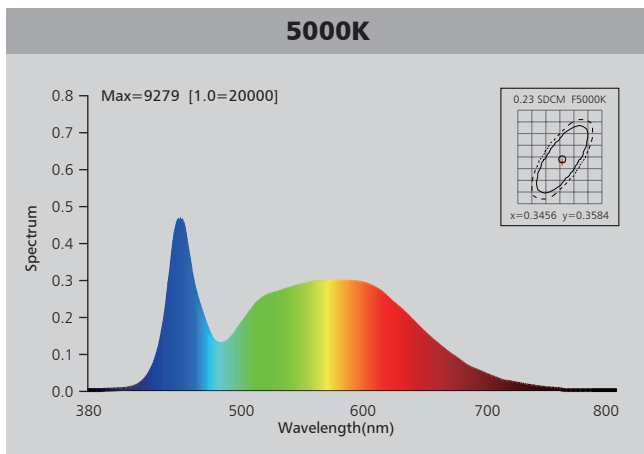
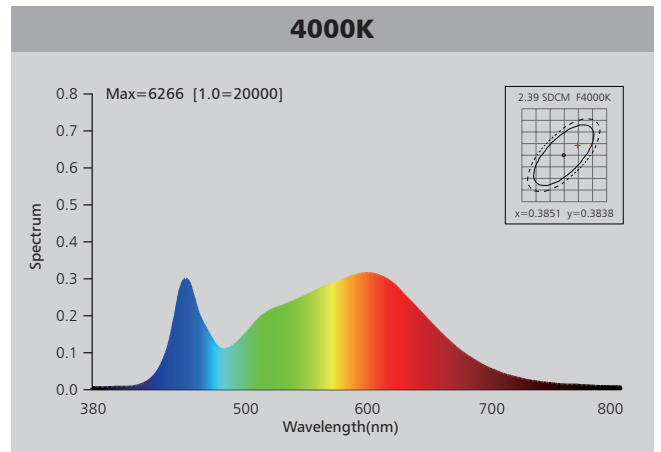
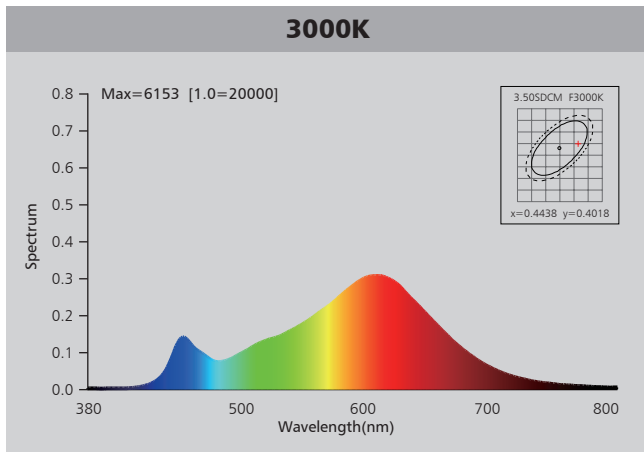

# Photometric Diagram

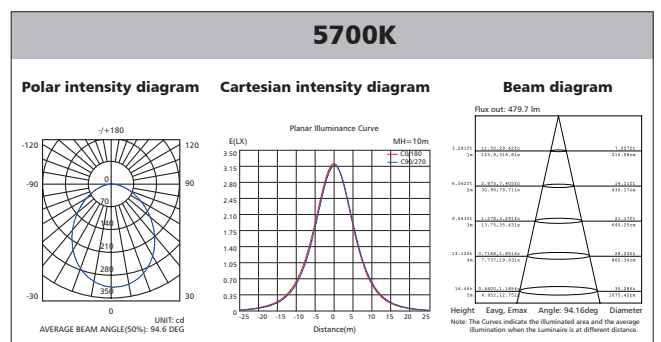
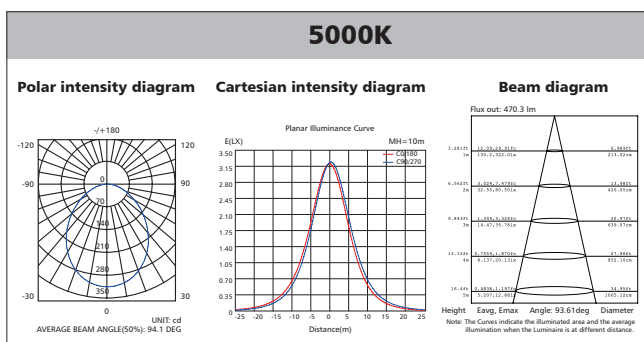
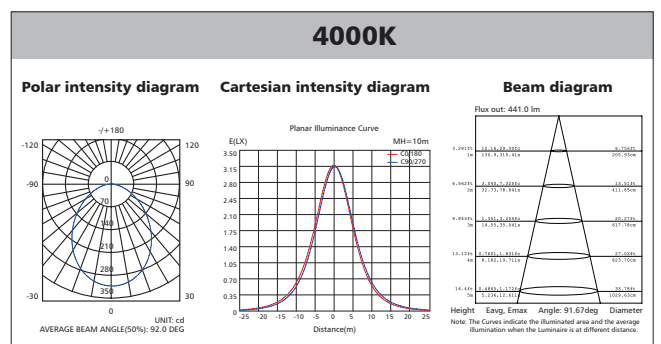
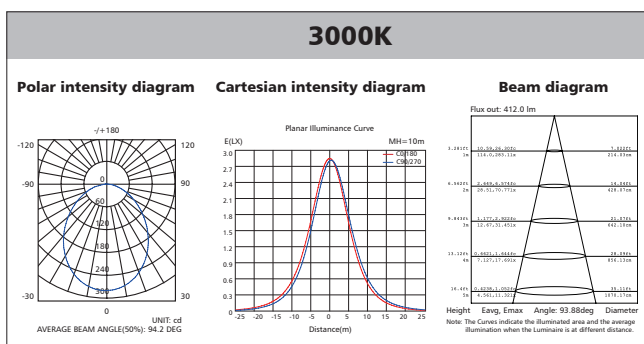

# Polar Diagram Comparison

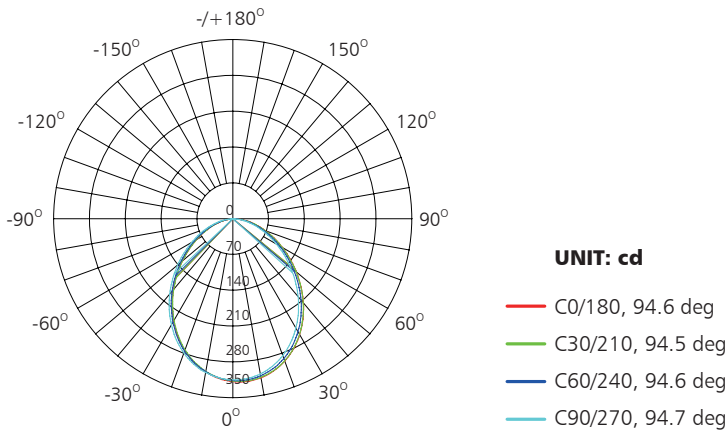

AVERAGE BEAM ANGLE (50%): 94.6DEG

# Driver lifetime & LED light decay rate

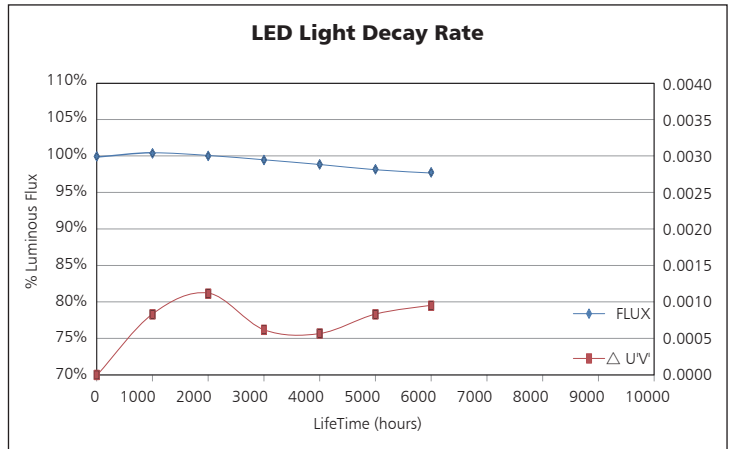
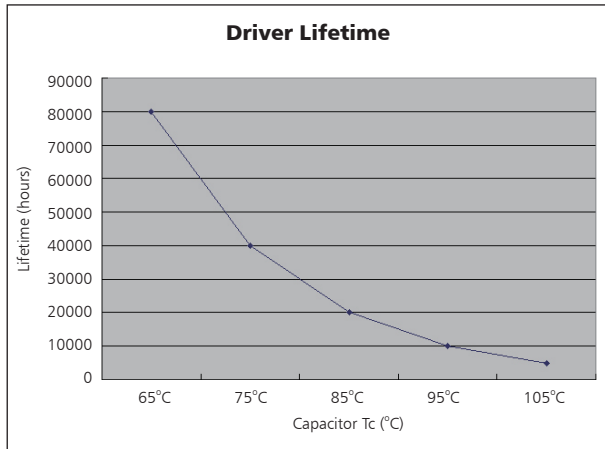

# Temperature

- The testing is operated at 25°C
- The lifetime of capacitor, minimum of 5,000 hours if operated at 105°C, will be doubled whenever the temperature drops 10°C
- The highest withstand temperature of IC, MOS could be 120°C
- The highest withstand temperature of LED junction temperature is 150°C

Time	IC	Capacitor	MOS	PCB	LED	Fitting	Environmental temperature
18:37:46	~65	~60	~70	~35	~60	~60	~25
19:07:44	~65	~60	~70	~35	~60	~60	~25
19:37:44	~65	~60	~70	~35	~60	~60	~25
20:07:44	~65	~60	~70	~35	~60	~60	~25
20:37:44	~65	~60	~70	~35	~60	~60	~25
21:07:44	~65	~60	~70	~35	~60	~60	~25
21:37:44	~65	~60	~70	~35	~60	~60	~25
22:07:44	~65	~60	~70	~35	~60	~60	~25
22:37:44	~65	~60	~70	~35	~60	~60	~25
23:07:44	~65	~60	~70	~35	~60	~60	~25
23:37:44	~65	~60	~70	~35	~60	~60	~25
0:07:44	~65	~60	~70	~35	~60	~60	~25
0:37:44	~65	~60	~70	~35	~60	~60	~25
1:07:44	~65	~60	~70	~35	~60	~60	~25
1:37:44	~65	~60	~70	~35	~60	~60	~25
2:07:44	~65	~60	~70	~35	~60	~60	~25
2:37:44	~65	~60	~70	~35	~60	~60	~25
3:07:44	~65	~60	~70	~35	~60	~60	~25
3:37:44	~65	~60	~70	~35	~60	~60	~25
4:07:44	~65	~60	~70	~35	~60	~60	~25
4:37:44	~65	~60	~70	~35	~60	~60	~25
5:07:44	~65	~60	~70	~35	~60	~60	~25
5:37:44	~65	~60	~70	~35	~60	~60	~25
6:07:44	~65	~60	~70	~35	~60	~60	~25
6:37:44	~65	~60	~70	~35	~60	~60	~25
7:07:44	~65	~60	~70	~35	~60	~60	~25
7:37:44	~65	~60	~70	~35	~60	~60	~25
8:07:44	~65	~60	~70	~35	~60	~60	~25
8:37:44	~65	~60	~70	~35	~60	~60	~25
9:07:44	~65	~60	~70	~35	~60	~60	~25

The driver lifespan is based on capacitor working temperature.

www.upshine.com info@upshine.com

# Installation

Install requirements	
A-gap above the fitting	25mm
B-gap to the building material	25mm
C-gap to the thermal insulation	25mm

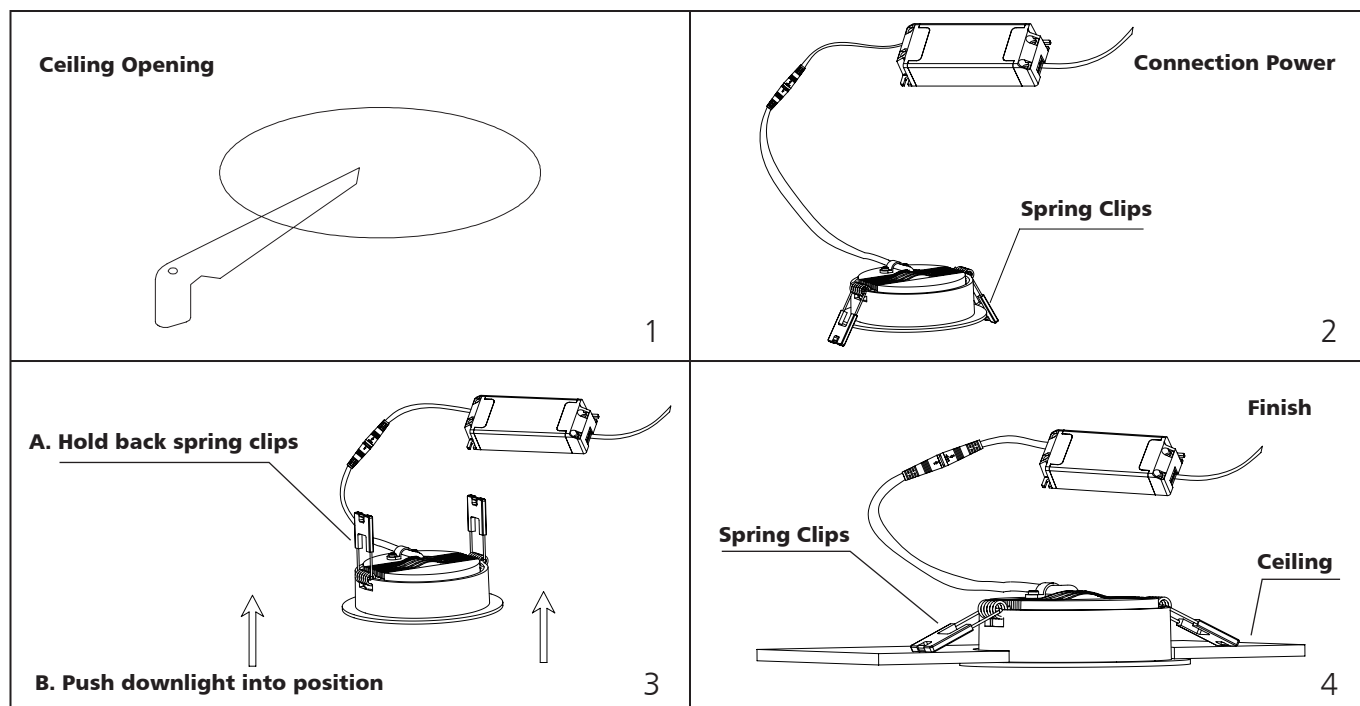
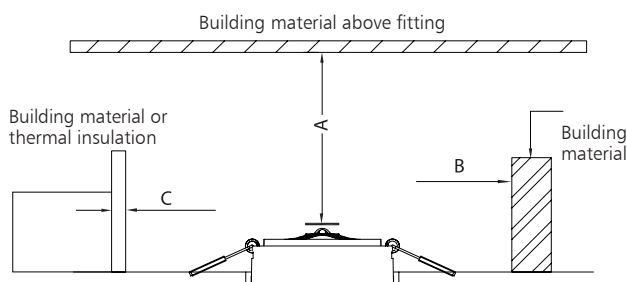

# Packaging Information

	SIZE(CM)	N.W/pc (KGS)	G.W.(KGS)	Q'TY(PCS)
Carton	46*46*30	0.27	18.5	64

	CTNS	Q'TY(PCS)	VOLUME(CBM)
20" standard container	434	27776	28
40" standard container	868	55552	56

