

# Technical Application Guide for UP-SHINE LED Downlight

UP-DL34-3-13W

# Introduction

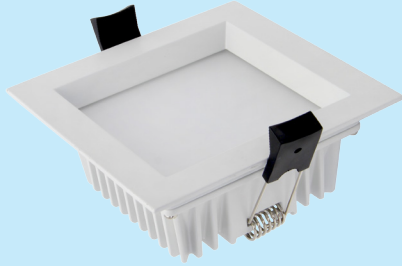

Up-shine square LED Down light adopts high lumen SMD LED, PMMA diffuser with even light output. White, silver, chrome surface treatment are available for different applications. Triac dimmable, 0-10V dimmable and DALI dimmable version share great popularity by the excellent dimming effect.

- Up to 70% energy saving compared to standard CFL
- Long lifetime of 40,000 hours
- Dimmable when using triac dimmer
- 90° wide beam angle
- 90-100mm cutout
- CCT: 3000K 4000K  
5000K 5700K
- No UV/IR light
- Environment friendly, without Mercury or any other hazardous substances

## Application notes

- IP20/IP44 for indoor use only
- Professional electrician for installation only
- Switch off before installation
- Do not touch when in use
- Keep away from hot steam and corrosive gas

## Application Areas

It is designed for general lighting applications in office, supermarket, shop, school, hotel, etc. It is also widely used for public areas, such as stairway, lobby, reception, corridors etc.

## Certificate



**RoHS**



# Product Information

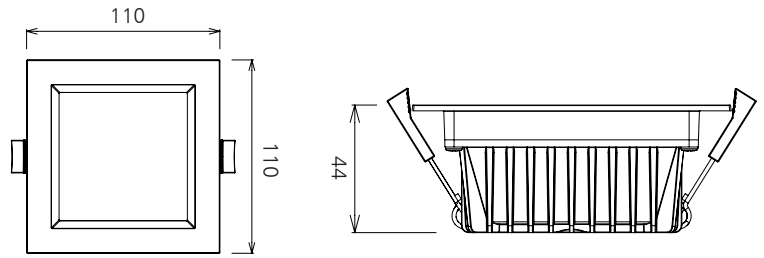

## Technical Specifications

Model	Voltage	Power	Power Factor	Lumen (±5%)	Beam angle	CCT	Lifespan	CRI	Dimmable	Dimension
UP-DL34-3-13W	AC100-240V	13W	≥0.9	920	90°	3000K	40000h	≥80	No	110*110*44mm cutout 90-100mm
UP-DL34-3-13W	AC100-240V	13W	≥0.9	930	90°	4000K	40000h	≥80	No	110*110*44mm cutout 90-100mm
UP-DL34-3-13W	AC100-240V	13W	≥0.9	935	90°	5000K	40000h	≥80	No	110*110*44mm cutout 90-100mm
UP-DL34-3-13W	AC100-240V	13W	≥0.9	940	90°	5700K	40000h	≥80	No	110*110*44mm cutout 90-100mm
UP-DL34-3-13WD	AC230V	13W	≥0.9	880	90°	3000K	40000h	≥80	Yes	110*110*44mm cutout 90-100mm
UP-DL34-3-13WD	AC230V	13W	≥0.9	890	90°	4000K	40000h	≥80	Yes	110*110*44mm cutout 90-100mm
UP-DL34-3-13WD	AC230V	13W	≥0.9	910	90°	5000K	40000h	≥80	Yes	110*110*44mm cutout 90-100mm
UP-DL34-3-13WD	AC230V	13W	≥0.9	920	90°	5700K	40000h	≥80	Yes	110*110*44mm cutout 90-100mm

## Driver data Sheet

Driver data	DIM	Non dim
Input rated Voltage	AC230V	AC100-240V
Frequency	50Hz	50/60Hz
Input Voltage	AC200-240V	AC85-265V
Efficiency	≥78%	≥86%
Total load Wattage	13W±1W	13W±1W
Power Factor	≥0.9	≥0.9
Rated input current	≤0.07A	≤0.15A
Full load output Voltage	DC29-33V	DC29-33V
Rated output current	330mA	350mA
Output current range	330mA±5%	350mA±5%
Power tolerance	±5%	±5%
Current output tolerance	±5%	±5%
Dimming range	8%-100%	——
Dimmer	Triac dimmers	——
Short circuit protection	PASS	PASS
Over voltage protection	PASS	PASS
Over temperature protection	PASS	PASS
Withstand voltage	AC3750V	AC3750V

## Fixture Compatibility

Rated Wattage	Electrical Classification	Ingress Protection	Operating Temp	Operating Humidity	Storage Temp
13W	II	IP20/IP44	-20°C~45°C	0~90%	-20°C~65°C

# Spectral Distribution

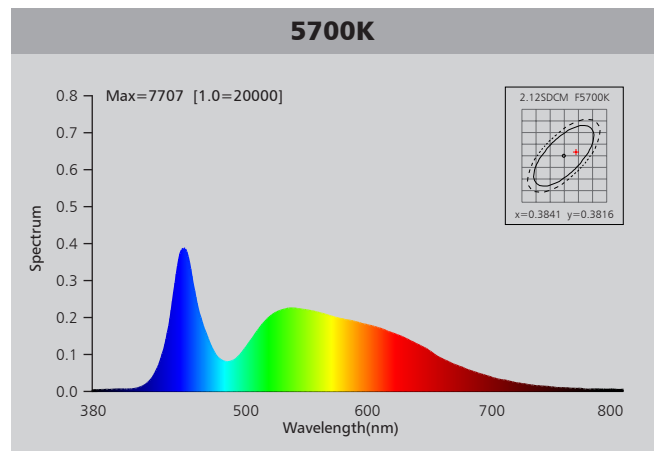
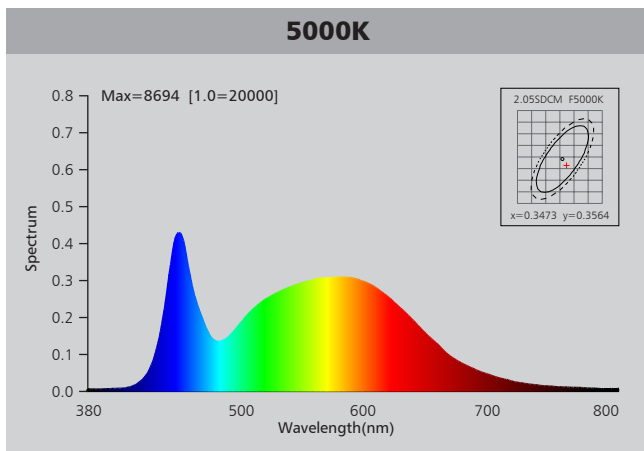
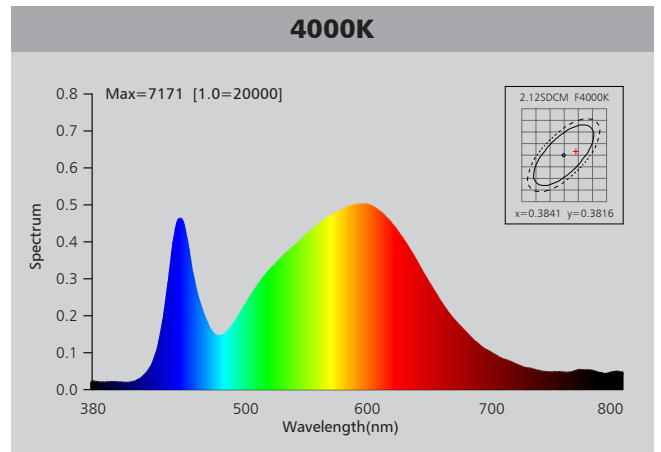
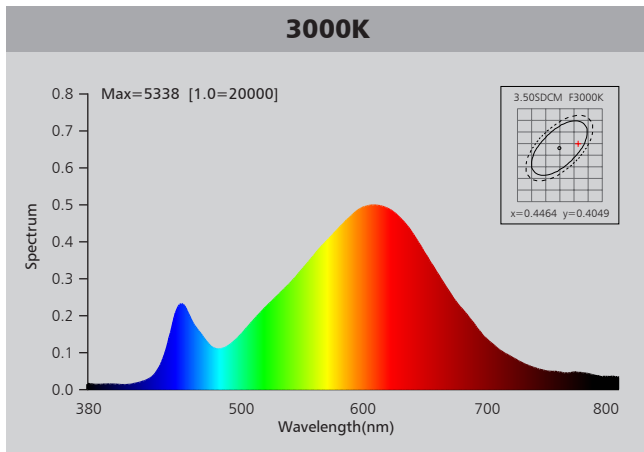

# Photometric Diagram

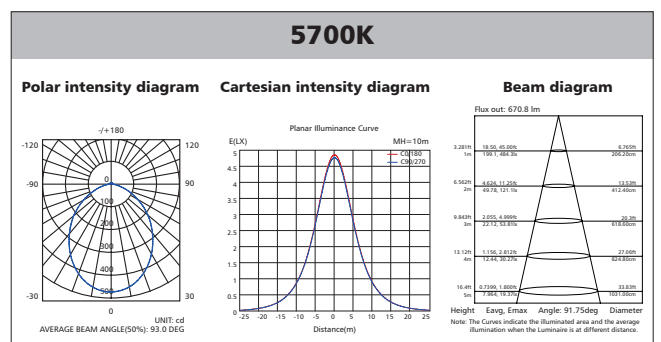
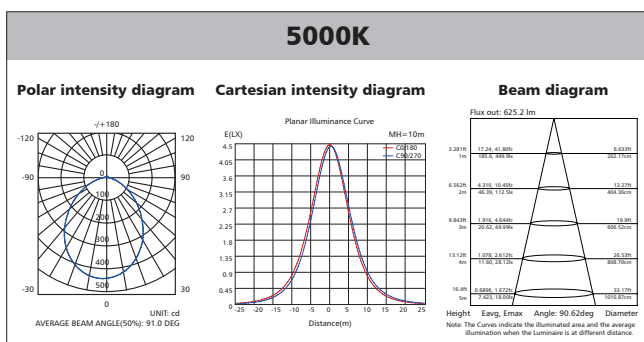
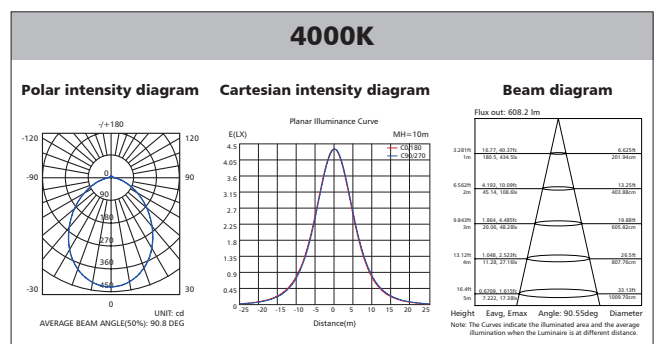
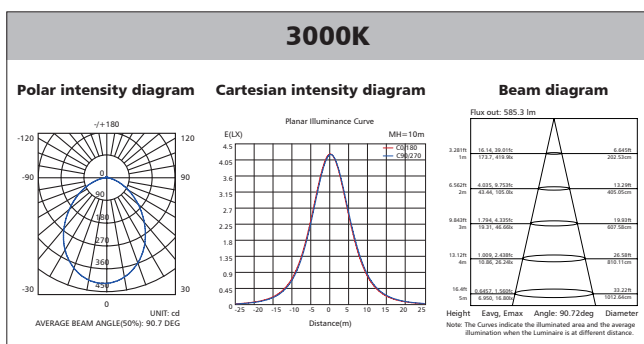

## Polar Diagram Comparison

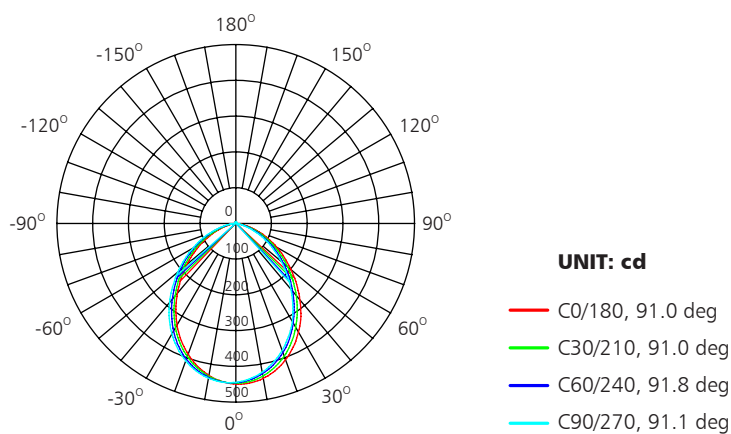

AVERAGE BEAM ANGLE (50%): 91.0DEG



## Driver lifetime & LED light decay rate

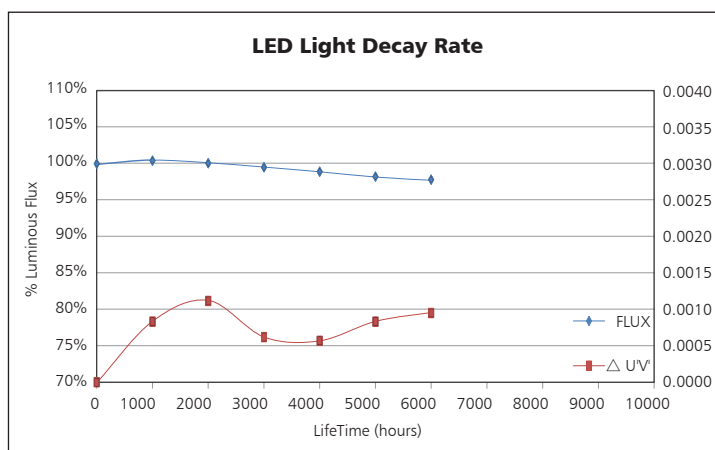
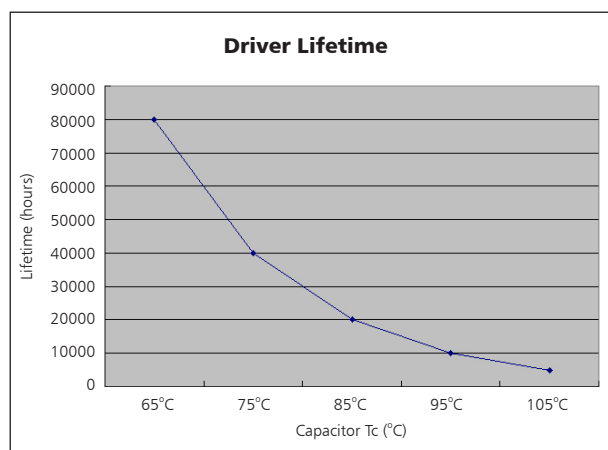

## Temperature

- The testing is operated at 25°C
- The lifetime of capacitor, minimum of 5,000 hours if operated at 105°C, will be doubled whenever the temperature drops 10°C
- The highest withstand temperature of IC, MOS could be 120°C
- The highest withstand temperature of LED junction temperature is 150°C

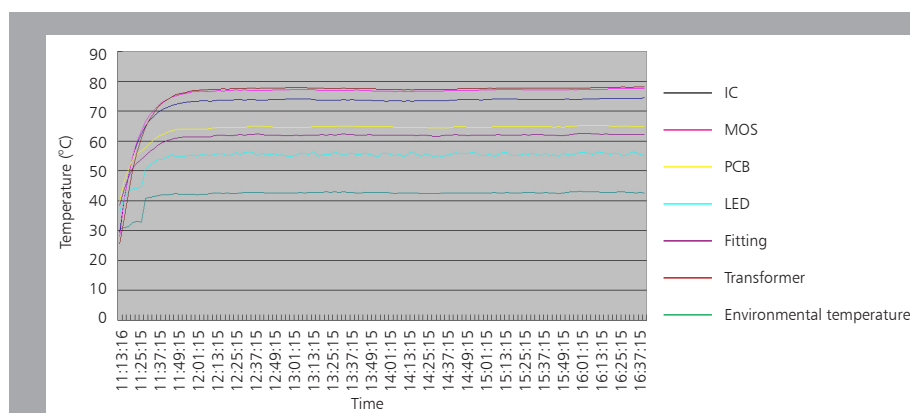

The driver lifespan is based on capacitor working temperature.

# Installation

Install requirements	
A-gap above the fitting	25mm
B-gap to the building material	25mm
C-gap to the thermal insulation	25mm

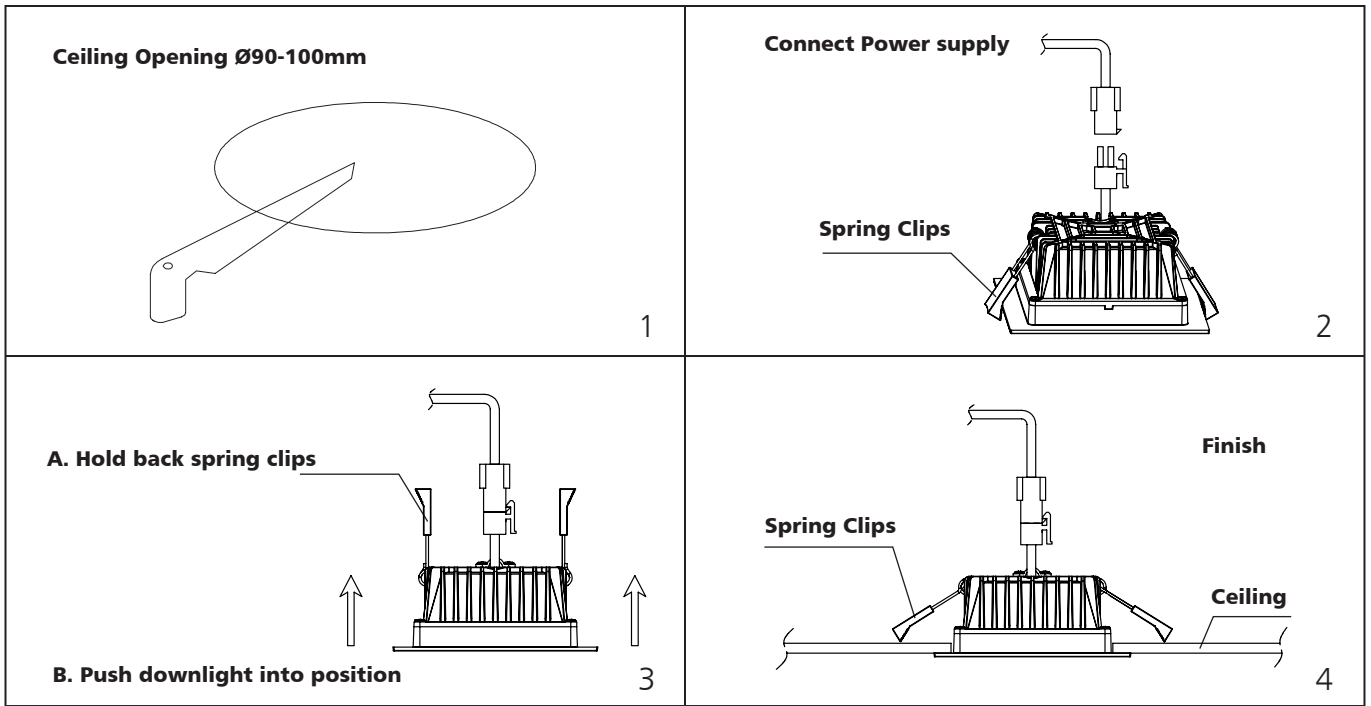
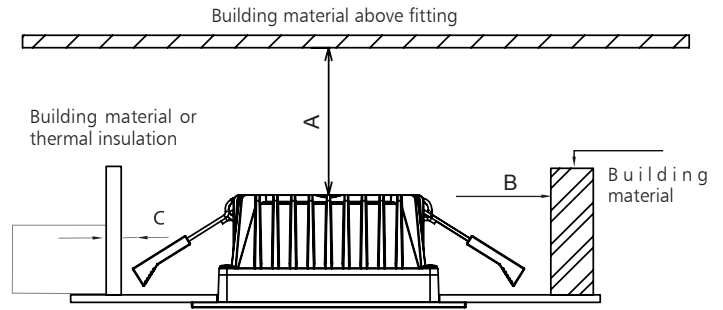

# Packaging Information

	SIZE(CM)	N.W/pc (KGS)	G.W.(KGS)	Q'TY(PCS)
Carton	47.5*43.5*22	0.4	12	24

	CTNS	Q'TY(PCS)	VOLUME(CBM)
20" standard container	605	14520	28
40" standard container	1210	29040	56

