



Up-shine<sup>®</sup> Lighting



Color  
Changeable



Dimmable

Technical Application  
Guide for UP SHINE  
LED Downlight  
UP-CL77-3-10W-P

# Introduction

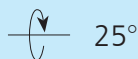
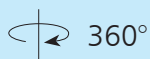
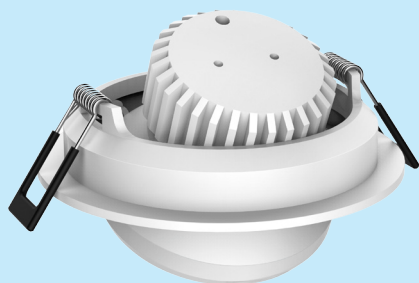

Color changeable mini downlight is special designed for European market with standard cutout size. CCT changes from 2000K~3000K by triac dimmers, wattage varies synchronously with color changing. 24°/36°/60° beam angle provided, applicable for various lighting effect. Smart optical design with combination of COB LED and PC reflector, maximally reduces UGR down to 19 or even less. Waterproof structural design, IP40 protection grade, ideally for damp locations. 25 degree flexible rotary head makes installation easier and better.

- Up to 70% energy saving compared to standard CFL
- Long lifetime of 40,000 hours
- Triac dim
- 15° / 24° / 36° / 60° wide beam angle
- Ø85-90mm cutout
- CCT: 2000K~2800K
- No UV/IR light
- Environment friendly, without Mercury or any other hazardous substances

## Application notes

- IP40 for indoor use only
- Professional electrician for installation only
- Switch off before installation
- Do not touch when in use
- Keep away from hot steam and corrosive gas

## Application Areas

It is designed for general lighting applications in home, office, shop, school, hotel, etc. It is also widely used for public areas, such as gallery, lobby, reception, corridors etc.

## Certificate



# Product Information

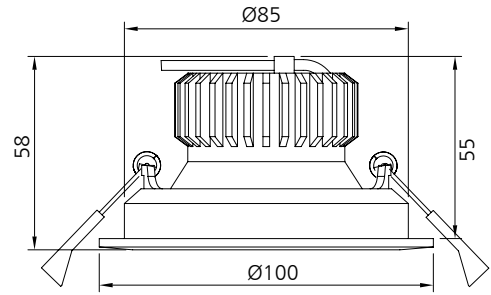

## Technical Specifications

Model	Voltage	Power	Power Factor	Lumen (±5%)	Beam angle	CCT	Lifespan	CRI	Dimmable	Dimension
UP-CL77-3-10W-P	AC230V	10W	≥0.9	450	15° / 24° 36° / 60°	2000-2800K	40000h	≥90	No	Ø100*58mm cutout Ø85-90mm

## Driver data Sheet

Driver data	DIM
Input rated Voltage	AC230V
Frequency	50Hz
Input Voltage	AC200-240V
Efficiency	≥75%
Total load Wattage	10W±1W
Power Factor	≥0.9
Rated input current	≤0.06A
Full load output Voltage	DC35-38V
Rated output current	220mA
Output current range	220mA±5%
Power tolerance	±5%
Current output tolerance	±5%
Dimming range	8%-100%
Dimmer	Triac dimmers
Short circuit protection	PASS
Over voltage protection	PASS
Over temperature protection	PASS
Withstand voltage	AC3750V

## Fixture Compatibility

Rated Wattage	Electrical Classification	Ingress Protection	Operating Temp	Operating Humidity	Storage Temp
10W	II	IP40	-20°C~45°C	0~90%	-20°C~65°C

# Spectral Distribution

## 2800K

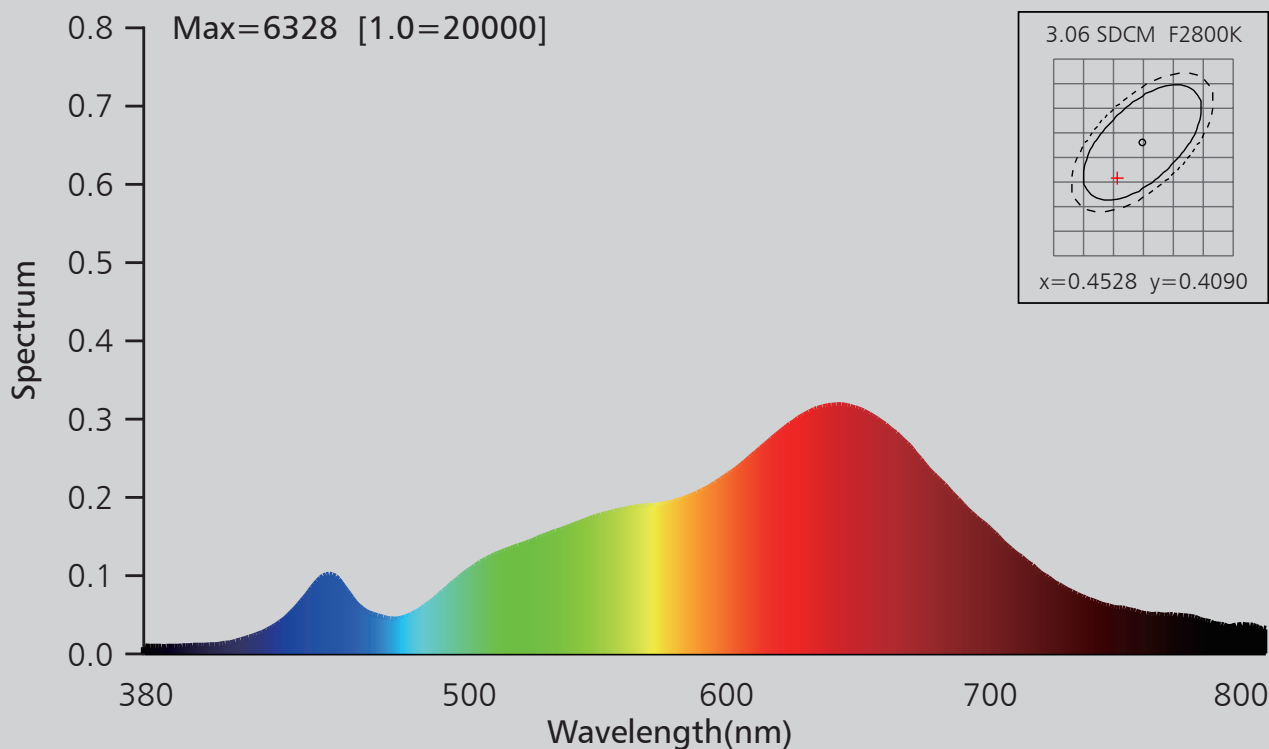

# Photometric Diagram

## 2800K

### Polar intensity diagram

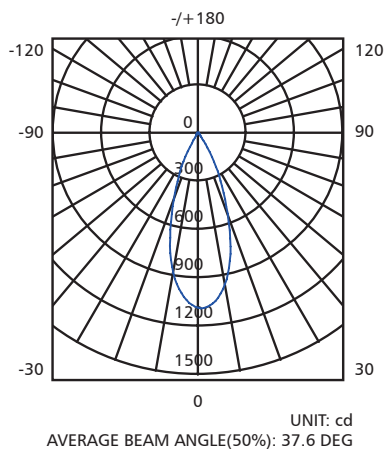

### Cartesian intensity diagram

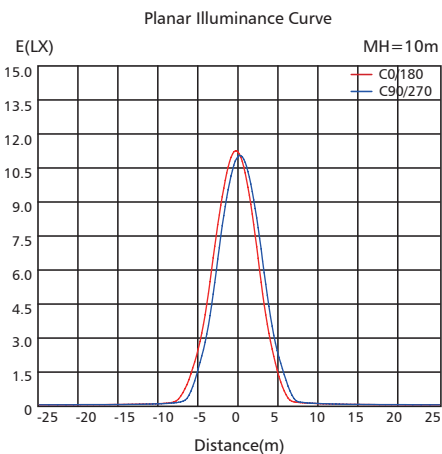

### Beam diagram

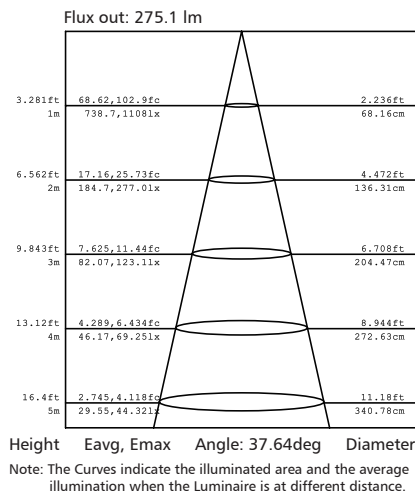

# Polar Diagram Comparison

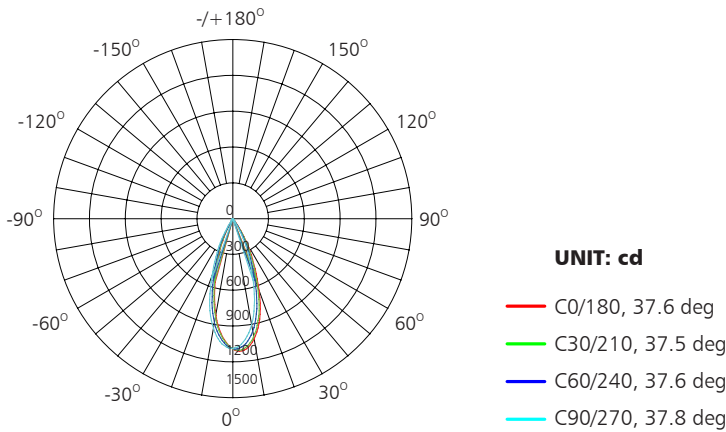

AVERAGE BEAM ANGLE (50%): 37.6 DEG



# Driver lifetime & LED light decay rate

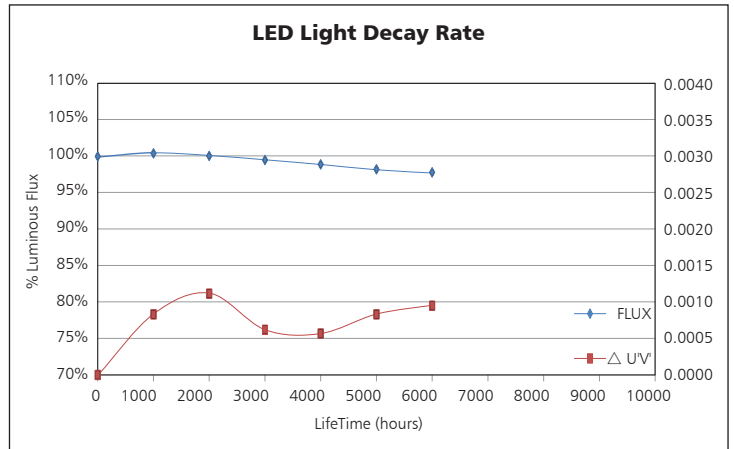
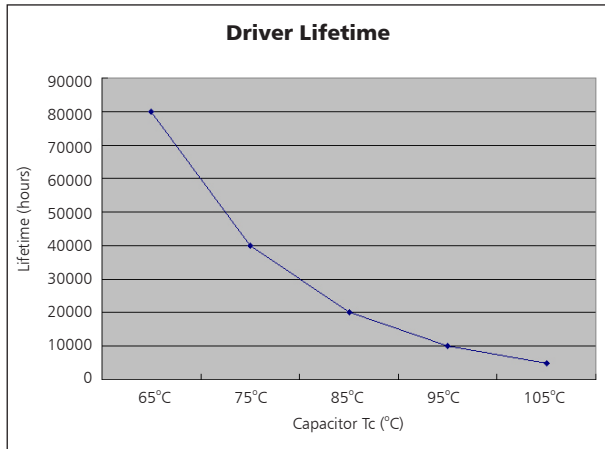

# Temperature

- The testing is operated at 25°C
- The lifetime of capacitor, minimum of 5,000 hours if operated at 105°C, will be doubled whenever the temperature drops 10°C
- The highest withstand temperature of IC, MOS could be 120°C
- The highest withstand temperature of LED junction temperature is 150°C

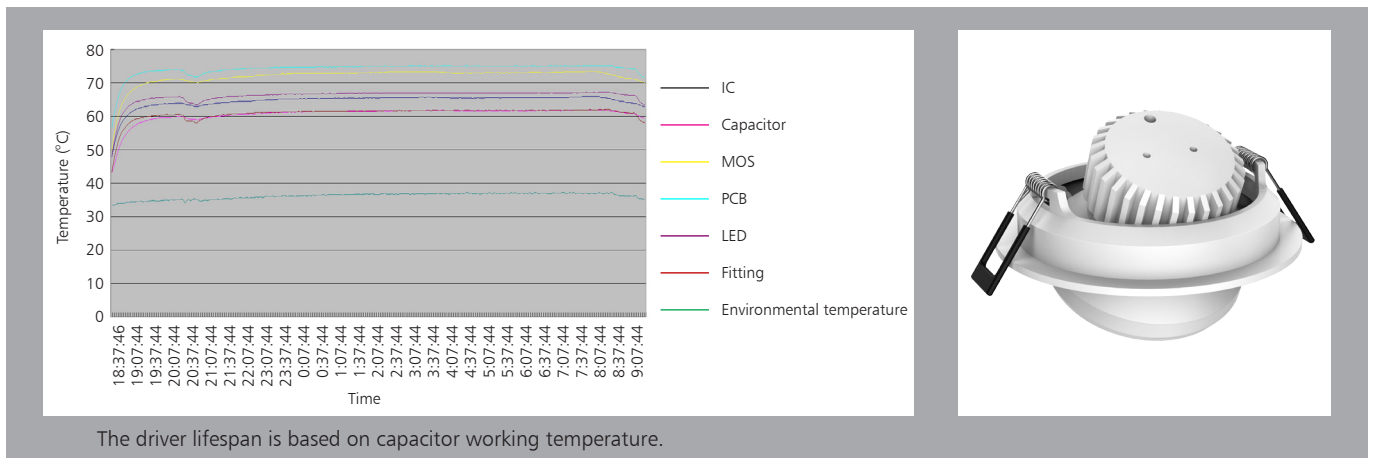

# Installation

Install requirements	
A-gap above the fitting	25mm
B-gap to the building material	25mm
C-gap to the thermal insulation	25mm

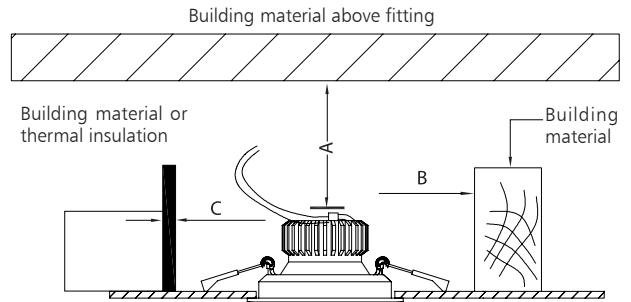

**Ceiling Opening**

1

**Connect Power supply**

2

**A. Hold back spring clips**

3

**B. Push downlight into position**

**Finish**

4

# Packaging Information

	SIZE(CM)	N.W/pc (KGS)	G.W.(KGS)	Q'TY(PCS)
Carton	46*46*29.5	0.34	17	48

	CTNS	Q'TY(PCS)	VOLUME(CBM)
20" standard container	440	21120	28
40" standard container	880	42240	56

